



National Aeronautics and
Space Administration

**MEASUREMENT
SYSTEM
IDENTIFICATION
METRIC/SI**

MSFC-SPEC-521
REVISION C
EFFECTIVE DATE: July 1, 2013

George C. Marshall Space Flight Center
Marshall Space Flight Center, Alabama 35812

ES42

MSFC TECHNICAL STANDARD

**ELECTROMAGNETIC COMPATIBILITY
REQUIREMENTS FOR EQUIPMENT AND
SUBSYSTEMS**

Approved for Public Release; Distribution is Unlimited

CHECK THE MASTER LIST—
VERIFY THAT THIS IS THE CORRECT VERSION BEFORE USE at
<https://repository.msfc.nasa.gov/docs/multiprogram/MSFC-SPEC-521>

MSFC Technical Standard ES42		
Title: Electromagnetic Compatibility Requirements for Equipment and Subsystems	Document No.: MSFC-SPEC-521	Revision: C
	Effective Date: July 1, 2013	Page 2 of 75

DOCUMENT HISTORY LOG

Status (Baseline/ Revision/ Canceled)	Document Revision	Effective Date	Description
Baseline		1/13/1978	Initial Baseline
Revision	A	3/16/1983	Replaces initial release in its entirety.
Revision	B	8/15/1990	Replaces Revision A in its entirety.
SCN	1	3/20/91	Replace Figure 3.3.
Revision	C	7/1/2013	Document authorized through the Multiprogram Document Management System (MPDMS). Complete revision to document. While similar in scope and topical treatment, its derivations are from current revisions of DoD standards, etc. Test methods, limits, and values have been brought into consistency with current state-of-the-industry counterparts.

MSFC Technical Standard ES42		
Title: Electromagnetic Compatibility Requirements for Equipment and Subsystems	Document No.: MSFC-SPEC-521	Revision: C
	Effective Date: July 1, 2013	Page 3 of 75

Table of Contents

LIST OF FIGURES	5
LIST OF TABLES	5
<u>TABLE</u>	5
1.0 INTRODUCTION	6
1.1 BACKGROUND	6
1.2 PURPOSE	6
1.3 SCOPE	7
1.4 E3 CONTROL PLAN	7
1.5 EMI TEST REPORT	8
1.6 MODIFICATIONS TO REQUIREMENTS	9
2.0 DOCUMENTS	9
2.1 APPLICABLE DOCUMENTS	9
2.2 REFERENCE DOCUMENTS	9
2.3 ORDER OF PRECEDENCE	10
3.0 REQUIREMENTS	10
3.1 SYSTEM COMPATIBILITY	10
3.1.1 FUNCTIONAL COMPATIBILITY	10
3.1.2 SAFETY CRITICAL CIRCUITS	10
3.2 DESIGN REQUIREMENTS	11
3.2.1 PRIMARY POWER	11
3.2.2 ENCLOSURE SHIELDING	13
3.2.3 ELECTRICAL BONDING	14
3.2.4 CIRCUIT CLASSIFICATION	14
3.2.5 WIRE TWISTING	14
3.2.6 WIRE SHIELDING	15
3.3 SUBSYSTEM AND EQUIPMENT EMISSION AND SUSCEPTIBILITY REQUIREMENTS	15
3.3.1 EQUIPMENT PRODUCED EMISSION	16
3.3.2 EQUIPMENT SUSCEPTIBILITY	27
4.0 VERIFICATION	39
4.1 GENERAL	39
4.2 VERIFICATION METHODS	39
4.2.1 ANALYSIS	39
4.2.2 INSPECTION	39
4.2.3 DEMONSTRATION	40
4.2.4 TEST	40
4.2.5 VALIDATION OF RECORDS	40
4.2.6 SIMILARITY	40
5.0 PACKAGING	50
6.0 NOTES	50
APPENDIX A ACRONYMS AND ABBREVIATIONS	51

MSFC Technical Standard ES42		
Title: Electromagnetic Compatibility Requirements for Equipment and Subsystems	Document No.: MSFC-SPEC-521	Revision: C
	Effective Date: July 1, 2013	Page 4 of 75

APPENDIX B TEST METHODOLOGIES	54
B.1 TEST CONFIGURATION SETUPS	54
B.2 CE107, CONDUCTED EMISSIONS, TIME DOMAIN, DC POWER LEVELS, TRANSIENT AND STEADY STATE	54
B.2.1 CE107 TEST PROCEDURES	54
B.2.2 CE108, CONDUCTED EMISSIONS, BULK CABLE EMISSION (BCE), 150 kHz TO 200 MHz	54
B.2.2.1 CE108 TEST PROCEDURES	54
B.2.3 CS106, POWER LINE SWITCHING TRANSIENTS	54
B.2.3.1 CS106 TEST PROCEDURES	54
B.1 TEST CONFIGURATION SETUPS	55
B.1.1 GROUND PLANE	55
B.1.1.1 METALLIC GROUND PLANE	55
B.1.1.2 COMPOSITE GROUND PLANE	57
B.1.1.3 GENERAL TEST REQUIREMENTS	57
B.1.1.4 TEST METHODOLOGY	57
B.1.1.5 ISN	57
B.2 CE107, CONDUCTED EMISSIONS, TIME DOMAIN, DC POWER LEVELS, TRANSIENT AND STEADY STATE	58
B.2.1 CE107 TEST PROCEDURES	58
B.2.1.1 PURPOSE	58
B.2.1.2 TEST EQUIPMENT	58
B.2.1.3 SETUP	58
B.2.1.4 PROCEDURE	60
B.2.1.5 DATA PRESENTATION	60
B.2.2 CE108, CONDUCTED EMISSIONS, BULK CABLE EMISSION (BCE), 150 kHz TO 200 MHz	60
B.2.2.1 CE108 TEST PROCEDURES	60
B.2.3 CS106, POWER LINE SWITCHING TRANSIENTS	63
B.2.3.1 CS106 TEST PROCEDURES	63
APPENDIX C REQUIREMENTS BACKGROUND AND GUIDANCE	67
C.1.0 INTRODUCTION	67
C.3.0 REQUIREMENTS	67
C.3.1 SYSTEM COMPATIBILITY	67
C.3.2 DESIGN REQUIREMENTS	68
C.3.2.1 PRIMARY POWER	68
C.3.2.2 ENCLOSURE SHIELDING	70
C.3.2.3 ELECTRICAL BONDING	70
C.3.2.4 CIRCUIT CLASSIFICATION	70
C.3.2.5 WIRE TWISTING	70
C.3.2.6 WIRE SHIELDING	70
C.3.3 SUBSYSTEM AND EQUIPMENT EMISSION AND SUSCEPTIBILITY REQUIREMENTS	70
C.3.3.1 EQUIPMENT PRODUCED EMISSION	71
C.3.3.2 EQUIPMENT SUSCEPTIBILITY	73

CHECK THE MASTER LIST VERIFY THAT THIS IS THE CORRECT VERSION BEFORE USE at
<https://repository.msfc.nasa.gov/docs/multiprogram/MSFC-SPEC-521>

MSFC Technical Standard ES42		
Title: Electromagnetic Compatibility Requirements for Equipment and Subsystems	Document No.: MSFC-SPEC-521	Revision: C
	Effective Date: July 1, 2013	Page 5 of 75

LIST OF FIGURES

1.	MSFC-SPEC-521C TEST SUMMARY CHART	16
2.	CE101 Limit for 28-volt applications, DC	17
3.	CE101 Limit for 120-volt applications, DC	18
4.	CE102 Limit for 28-volt applications, DC	19
5.	CE102 Limit for 120-volt applications, DC	20
6.	CE107 Power source transient excursion limit for 28 V DC applications	22
7.	CE107 Power source transient excursion limit for 120 V DC applications	23
8.	CE108 BCE limit for all applications	24
9.	RE102 Limit for all applications	26
10.	CS101 Voltage limit for 28 Vdc applications	28
11.	CS101 Voltage limit for 120 Vdc applications	29
12.	CS101 Power limit for 28 Vdc applications	30
13.	CS101 Power limit for 120 Vdc applications	31
14.	CS106 Transients envelope for 28 Vdc applications	32
15.	CS106 Transients envelope for 120 Vdc applications	33
16.	CS109 Current Limit for all applications	34
17.	CS114 Calibration limit for all applications	35
18.	Typical CS116 damped sinusoidal waveform	36
19.	CS116 Limit	37
20.	RS101 Test limit for all applications	38
21.	General test setup with a conductive ground plane	55
22.	Test setup for nonconductive surface mounted EUT	56
23.	Test setup for free-standing EUT in shielded enclosure	57
24.	CE107 Measurement system check setup	59
25.	CE107 Measurement setup	59
26.	CE108 Calibration diagram	61
27.	CE108 Bulk cable emission test setup	62
28.	CS106 Calibration setup	65

LIST OF TABLES

TABLE

I.	RS103 Limits	39
II.	Verification Methods	42

MSFC Technical Standard ES42		
Title: Electromagnetic Compatibility Requirements for Equipment and Subsystems	Document No.: MSFC-SPEC-521	Revision: C
	Effective Date: July 1, 2013	Page 6 of 75

1.0 INTRODUCTION

1.1 Background

Marshall Space Flight Center – Specification (MSFC-SPEC)-521 was initially published in 1978 to (1) interpret and integrate the various electromagnetic compatibility (EMC) requirements found in Shuttle, Spacelab, and payloads system documentation, and (2) document them for payload subsystems and equipment. The requirements of this specification, from its basic revision through revision B, were primarily derived from the Spacelab Payload (SLP) Accommodation Handbook, SLP-2104; the Orbiter/Spacelab Interface Control Document (ICD), 2-05301; Military Standard (MIL-STD)-461; National Space Transportation System (NSTS)-SL-E-0002; the Material Science Laboratory (MSL) User's Handbook, JA655; and the Space Shuttle Payload Accommodations Handbook, Volume XIV of NSTS 07700.

Although written specifically for Spacelab payloads, the specification became a *de facto* EMC standard for MSFC hardware where equipment and system level requirements did not exist or were unknown at the beginning of the development process.

Currently, MIL-STD-461, “Requirements for the Control of Electromagnetic Interference Characteristics of Subsystems and Equipment,” and MIL-STD-464 “Electromagnetic Environmental Effects Requirements for Systems,” are the engineering standards endorsed by the National Aeronautics and Space Administration (NASA) Office of Chief Engineer for electromagnetic interference (EMI) control and system-level EMC. MIL-STD-461 and MIL-STD-464 are applicable to all activities and agencies of the Department of Defense (DoD). Because of the broad applicability of these standards, the documents allow for tailoring of requirements commensurate with the intended installation and operation of the equipment and subsystems.

Because MIL-STD-461 and MIL-STD-464 are intended for all DoD activities, the scope of requirements exceeds those generally required for spaceflight programs and projects. Blind compliance with these standards frequently results in over-specification and excessive costs.

In accordance with NASA Procedural Requirements (NPR) 7120.10, “Technical Standards for NASA Program and Projects”, MSFC-SPEC-521C, presented herein, is a tailored version of MIL-STD-461 and MIL-STD-464. The scope of the specification is intended to meet the needs of a substantial majority of MSFC Programs and Projects to prevent over-specification of requirements, yet still maintain EMC.

1.2 Purpose

The basic EMC requirement for a system is that all included subsystems shall be able to operate compatibly during the mission. To accomplish this, requirements are imposed at two levels: one

CHECK THE MASTER LIST VERIFY THAT THIS IS THE CORRECT VERSION BEFORE USE at
<https://repository.msfc.nasa.gov/docs/multiprogram/MSFC-SPEC-521>

MSFC Technical Standard ES42		
Title: Electromagnetic Compatibility Requirements for Equipment and Subsystems	Document No.: MSFC-SPEC-521	Revision: C
	Effective Date: July 1, 2013	Page 7 of 75

at the system level, the other at the equipment or subsystem level. While some system-level requirements are outlined here, the primary objective of this document is to define equipment-level requirements to which the equipment developer shall adhere.

1.3 Scope

This document defines the minimum EMC requirements to be imposed on any payload electrical and/or electronic equipment to be transported by launch vehicle or spacecraft carrier systems. This includes experiment equipment and flight support equipment subsystems that are payload elements of the launch vehicle, spacecraft, or free-flying satellite.

Since this specification is intended to provide, at low cost, reasonable confidence that payload equipment can operate compatibly within the operating environment, only the most important emission and susceptibility requirements have been chosen. Some requirements have been converted into more usable terms, and some have been modified to be more easily verified.

The intent of this specification is to address the EMC needs of 80 percent of equipment and subsystems developed for small MSFC projects. As such, for example, not all requirements of MIL-STD-461 are represented in Section 3 of this document. Other requirements, necessary to achieve EMC on previous NASA Programs and Projects, are contained in Section 3. Information is provided in the Appendices to aid the Program, Project manager, and Electromagnetic Environmental Effects (E3) engineer in developing these requirements.

Recognizing that a discussion of EMC requirements at the hardware equipment level also brings into focus certain system-level requirements, some system-level aspects of an EMC program are referred to in this specification: for example, the design and arrangement of hardware equipment enclosure connectors must be in concert with the compatible development of the system's interconnecting wiring and cabling; and proper attention must be paid to the development of an electrical bonding plan that will be compatible with the bonding provisions being designed into the hardware items that are within the scope of this document. These and other higher-level considerations may be examined in the system E3 Control Plan.

1.4 E3 Control Plan

The system-level E3 Control Plan (MSFC Standard Data Requirements Document # STD/Design and Development Engineering (DE)-EMP) is a requirement of Marshall Procedural Requirements (MPR) 7123.2 "Technical Reviews and Review Item Discrepancy (RID) Processing, MSFC Programs and Projects," and is applicable to the system (whole payloads, free-flying satellites, rocket stages, etc.) under consideration.

E3 engineers must have a systems engineering overview of the design, manufacturing, and test activities relevant to the system to properly support development of the E3 Control Plan. This will ensure that bonding, isolation, shielding, and other requirements of this document are satisfactorily addressed by the hardware items produced.

CHECK THE MASTER LIST VERIFY THAT THIS IS THE CORRECT VERSION BEFORE USE at
<https://repository.msfc.nasa.gov/docs/multiprogram/MSFC-SPEC-521>

MSFC Technical Standard ES42		
Title: Electromagnetic Compatibility Requirements for Equipment and Subsystems	Document No.: MSFC-SPEC-521	Revision: C
	Effective Date: July 1, 2013	Page 8 of 75

1.5 EMI Test Report

The equipment level EMI qualification test report should include, as a minimum, the following information:

- a. Description of the equipment under test (EUT), including its function, characteristics, and description of cables used during testing.
- b. List of tests performed with pass/fail indications.
- c. Any approved deviations from test procedures or limits.
- d. Traceability of test equipment calibration.
- e. A reference to the approved EMI test procedure.
- f. Nomenclature of test equipment.
- g. Serial numbers of test equipment and version of software used.
- h. Calibration due date of test equipment.
- i. Photographs or diagrams of the actual test set up and EUT, with identification
- j. Transfer impedance of current probes.
- k. Antenna factors.
- l. Impedance values of Line Impedance Stabilization Networks (LISN).
- m. The ambient radiated and conducted electromagnetic emission profile of the test facility.
- n. Scan speeds.
- o. Measurement receiver bandwidths.
- p. Antenna polarization.
- q. Power line voltages, frequencies (where applicable), and power consumption or current usage.
- r. Low-noise amplifiers (LNA) compression points.

MSFC Technical Standard ES42		
Title: Electromagnetic Compatibility Requirements for Equipment and Subsystems	Document No.: MSFC-SPEC-521	Revision: C
	Effective Date: July 1, 2013	Page 9 of 75

1.6 Modifications to Requirements

If an equipment developer intends to place on equipment builders additional or more stringent requirements than those stated here, those new requirements to be imposed must first be documented in detail. Two acceptable methods of documenting details of new requirements would be: (1) In the systems level E3 control plan, or (2) as a line item in the preliminary requirements review documentation. Note that an E3 Control Plan is not necessarily required at the equipment level.

2.0 DOCUMENTS

2.1 Applicable Documents

The following documents include specifications, models, standards, guidelines, handbooks and other special publications. The documents listed in this paragraph are applicable to the extent specified herein.

Document Number	Document Title
NPR 7120.10	Technical Standards for NASA Programs and Projects
MWI 8050.1	Verification & Validation of Hardware, Software, and Ground Support Equipment for MSFC Projects

2.2 Reference Documents

Document Number	Document Title
JSC-CR-06070	Space Vehicle RF Environments
SAE AS5698	Space Power Standard
MIL-STD-461F	Requirements for the Control of Electromagnetic Interference Characteristics of Subsystems and Equipment
MIL-STD-464C	Electromagnetic Environmental Effects Requirements for Systems
RTCA DO-160G	Environmental Conditions and Test Procedures for Airborne Equipment, Section 20, Radio Frequency Susceptibility (Radiated and Conducted) and Section 21, Emission of Radio Frequency Energy
NASA-STD-4003A	Electrical Bonding for NASA Launch Vehicles, Spacecraft, Payloads, and Flight Equipment

MSFC Technical Standard ES42		
Title: Electromagnetic Compatibility Requirements for Equipment and Subsystems	Document No.: MSFC-SPEC-521	Revision: C
	Effective Date: July 1, 2013	Page 10 of 75

NASA RP 1368	Marshall Space Flight Center Electromagnetic Compatibility Design and Interference Control (MEDIC) Handbook (MSFC Center Director's Discretionary Fund Final Report, Project 93-15)
SL-E 0002, Book 3, Volume 1	Space Shuttle Specification: Electromagnetic Interference Characteristics, Requirements for Equipment – Book 3 New or Modified Equipment
TOR-2012(1663)-1	Cape Canaveral Radio Frequency Environment: Eastern Range

2.3 Order of Precedence

In the event of a conflict between the text of this document and the references cited herein, the text of this document takes precedence. Nothing in this document, however, supersedes applicable laws and regulations unless a specific exemption has been obtained.

3.0 REQUIREMENTS

3.1 System Compatibility

3.1.1 Functional Compatibility

Equipment shall not generate interference that degrades performance or causes malfunction on the platform, in the carrier, or in other subsystems. Equipment shall not malfunction due to susceptibility to emissions in its operating environment.

3.1.2 Safety Critical Circuits

Any equipment, along with its associated cabling, that contains safety critical circuits shall be required to meet the standard 6 decibel (dB) safety margin (16.5 dB for pyrotechnic circuits) between the susceptibility of the circuit and the interference present in the mission/flight environment. The designer shall provide definition of actual threshold sensitivity or susceptibility levels for safety critical circuits. This data will be used in the systems analysis or test planning.

A circuit shall be considered a safety critical circuit if the function of that circuit falls into one or more of the following categories:

- a. A circuit that provides power necessary to maintain the safe status of the payload or spacecraft system
- b. A circuit that inhibits power to a hazardous function

MSFC Technical Standard ES42		
Title: Electromagnetic Compatibility Requirements for Equipment and Subsystems	Document No.: MSFC-SPEC-521	Revision: C
	Effective Date: July 1, 2013	Page 11 of 75

- c. A circuit that provides control of a safety inhibit
- d. A circuit used to monitor the safety status of payload or spacecraft functions, devices, inhibits, or other safety related parameters

3.2 Design Requirements

3.2.1 Primary Power

Primary Power is considered the vehicle power (e.g. 28 Volt (V) vehicle power) and secondary refers to conditioned power (e.g. 15V direct current (DC) power).

Electrical Power System (EPS) Interface 1 is the point at which the voltage source is mated to a common interface (bus tie) for the Power System. The Main, or Primary on each side of the interface, is the level in the power distribution system where Power Systems are electrically tied together. EPS Interface 2 is at the input terminals or input connector pins for electrical loads, which are fixed.

3.2.1.1 System

Primary Power will utilize a distributed Single Point Ground (SPG) where the power source is grounded and loads are isolated.

Rationale: An electrical system is grounded for three reasons: safety, enhanced operability of the circuit, and EMI control. Some electrical circuits require grounding to a common reference plane (“ground” plane) in order to operate efficiently. A single reference to structure prevents unwanted DC and noise currents from circulating through structure, thereby mitigating potential EMI problems. In order to establish a distributed SPG for the EPS, it is necessary to define isolation requirements at the equipment interface. It is also necessary to ensure that secondary electrical power systems and electrical signals routed external to equipment meet the isolation requirements to prevent multiple references to structure (ground loops).

3.2.1.2 Equipment/Line Replaceable Unit (LRU) Power Grounding

3.2.1.2.1 Interface 1

Voltage sources shall reference to ground either the supply or return conductor of the voltage output. If more than one voltage is sourced then the power source shall ground the reference or neutral lead.

The grounding circuit shall be fully enclosed in the chassis of the voltage source (e.g. no grounding lead requiring an external connection shall be used).

MSFC Technical Standard ES42		
Title: Electromagnetic Compatibility Requirements for Equipment and Subsystems	Document No.: MSFC-SPEC-521	Revision: C
	Effective Date: July 1, 2013	Page 12 of 75

3.2.1.2.2 Interface 2

DC Power consumers/converters/conditioners/distributors/etc. connected to primary power shall maintain at least 1 Megaohm (MΩ) DC isolation between both the high and return lines when measured against chassis. This includes all operational modes.

Isolation between primary power line and each secondary power lines shall be greater than 1 MΩ DC.

Equipment using alternating current (AC) power shall limit capacitance to case so that the device meets the leakage current requirements of the applicable Underwriters Laboratories (UL) specification for the equipment.

3.2.1.2.3 Secondary Power

Secondary power supply and return conductors shall be isolated from primary power supply and return conductors by at least 1Mohm resistance using transformer isolated DC-to-DC converters, DC-to-AC inverters, or other isolation.

In cases where secondary power is not isolated from primary power by at least 1Mohm resistance, if secondary power is not further referenced to ground or connected to other circuitry referenced to ground, then the intent of this requirement is met.

3.2.1.3 Equipment/LRU Signals Grounding Considerations

3.2.1.3.1 Signal Grounding

Signal circuitry routed external to equipment shall be isolated from chassis/structure by at least 1 MΩ except at a single reference to structure on the transmit or source end (the reference is not necessary).

3.2.1.3.2 Signal Returns

Each signal, command, control, and power circuit routed externally to the equipment shall employ a separate return and shall be isolated from harness shields and destination chassis by a minimum resistance of 1 MΩ.

Signal returns for circuits using separate derived power sources shall be isolated by a minimum resistance of 1 MΩ.

Note: Some databus protocols such as Electronics Industries Association (EIA) Recommended Standard (RS)-232 and RS-423 utilize one return for multiple signals. The intent of this requirement is met when equipment meets such databus protocols and complies with the other requirements of this specification.

MSFC Technical Standard ES42		
Title: Electromagnetic Compatibility Requirements for Equipment and Subsystems	Document No.: MSFC-SPEC-521	Revision: C
	Effective Date: July 1, 2013	Page 13 of 75

Commentary: Testing isolation of signal returns must be performed prior to connecting cables and equipment. Connector pins, connected to signal returns in the equipment containing the power source, should measure continuity to chassis ground. Signal returns in cables or equipment not containing or connected to the power source should measure at least 1 M Ω when measured from return to equipment chassis or cable shield. At least 1 M Ω should also be measured between signal returns for circuits using separate derived power sources.

3.2.1.3.3 Balanced Differential Circuit Isolation

Balanced differential circuits external to equipment shall be isolated from chassis by 6 Kilohms (k Ω) or greater. Line drivers and receivers having balanced receivers and low impedance drivers are considered balanced circuits even though the source is referenced to ground.

3.2.1.3.4 Coaxial Shields

Coax cabling shall be permitted only when all frequency components of the signal are greater than or equal to 1 Megahertz (MHz). Coax shall not be used as interconnects between equipment utilizing different power sources unless electrical isolation is provided (opto-isolators, transformers, etc.) to prevent violation of SPG architecture.

3.2.2 Enclosure Shielding

Thin shields of aluminum, copper, or steel are effective for radio frequency (RF) radiated fields. However, for low frequency magnetic fields (<500 Kilohertz (kHz)), either thicker steel or magnetic material (with a high relative magnetic permeability, μ_r) is required. The shielding effectiveness of an enclosure is degraded by the holes, seams, and joints in the enclosure. Leakage through seams, holes, and joints is usually a greater concern than the shielding effectiveness of the enclosure material. The following are some general guidelines for enclosure shielding:

- a. The maximum linear dimension of the opening, not the area, determines the amount of leakage.
- b. A slot or rectangular hole may act as a slot antenna when the maximum linear dimension of the slot becomes greater than 1/10 of a wavelength.
- c. A large number of holes will allow less leakage than one large hole of the same total area.
- d. An aperture with a depth greater than the maximum linear dimension of the aperture will act as a waveguide. This waveguide will offer greater attenuation than a “regular” hole pattern for frequencies lower than the waveguide’s critical frequency. The critical frequency is roughly the frequency whose half wavelength equals the maximum linear dimension of the opening.

MSFC Technical Standard ES42		
Title: Electromagnetic Compatibility Requirements for Equipment and Subsystems	Document No.: MSFC-SPEC-521	Revision: C
	Effective Date: July 1, 2013	Page 14 of 75

e. Good electrical contact along seams or joints is necessary to maintain shielding effectiveness. The mechanical design must provide for a conductive finish and adequate contact force between the mating surfaces.

f. For equipment enclosures that require ventilation, the following materials (in descending order of attenuation) should be used to cover the opening:

1. Waveguide below cutoff panels (honey-comb panels)
2. Perforated metal sheet
3. Woven or knitted metal mesh.

3.2.3 Electrical Bonding

The equipment shall have provisions to allow its case(s) to be bonded to structure. The bonding provisions shall be for metal-to-metal contact of bare surfaces or surfaces with a qualified conductive finish or for a ground-strap-to-structure bond. The bonding surface area shall be 4 times the cross-sectional area of a cable conductor that could safely carry the expected current in the bond path. This bonding surface area shall be prepared such that it is clean and free of paint or any type of non-conductive conversion coating. Bare, clean, metal-to-metal contact will ensure a low-impedance connection between mating surfaces. If a bonding strap is used, it should have a length-to-width ratio less than 5:1. The preferred method of bonding is through the mounting surface to structure.

3.2.4 Circuit Classification

Wiring classification criteria is typically dependent on frequency content, voltage level, current amplitude and circuit impedance. Wire bundles of differing EMC classification shall be physically separated from each other. Where no metallic shield, other than an individual braided shield, exists between them, each classification shall be separated from all other classes by a minimum of 5 centimeters. Exceptions for short runs are allowed where all classes may be routed together for parallel runs totaling less than 3 feet in length. When both power and signal circuits are present at the interface, a minimum of two connectors should be used. In cases where only one connector exists on an enclosure, the pins should be assigned to facilitate separation of the wire bundles outside the enclosure. Separation of these wire classes internal to experiment subsystems is recommended.

3.2.5 Wire Twisting

Circuits that interconnect equipment shall provide for minimum loop coupling and maximum field cancellation by twisting of return with high side. Both signal and power circuits shall be

MSFC Technical Standard ES42		
Title: Electromagnetic Compatibility Requirements for Equipment and Subsystems	Document No.: MSFC-SPEC-521	Revision: C
	Effective Date: July 1, 2013	Page 15 of 75

twisted with their respective returns. Multiple circuits using a common return shall be twisted as a group. Twisting tighter than that required to hold the wires together is usually unnecessary.

3.2.6 Wire Shielding

Wire shields shall cover the twisted pair or twisted group rather than individual wires. No shield shall intentionally carry current except for coax cables used with radio frequencies only (1 MHz and above). Circuit shields should normally be grounded to the equipment case at each end. The preferred method of grounding shields is through a conductive backshell that makes good electrical contact to the equipment case. Overall shields may be used over a cable bundle for additional protection and shall also be grounded to equipment case at each end. Electrical connectors that may be used to terminate cable shields shall be installed to provide a low impedance path to the equipment case. Mounting surfaces shall be clean and free of nonconductive material. The dc resistance between the connector and case shall not exceed 2.5 milliohms.

3.3 Subsystem and Equipment Emission and Susceptibility Requirements

MSFC Technical Standard ES42		
Title: Electromagnetic Compatibility Requirements for Equipment and Subsystems	Document No.: MSFC-SPEC-521	Revision: C
	Effective Date: July 1, 2013	Page 16 of 75

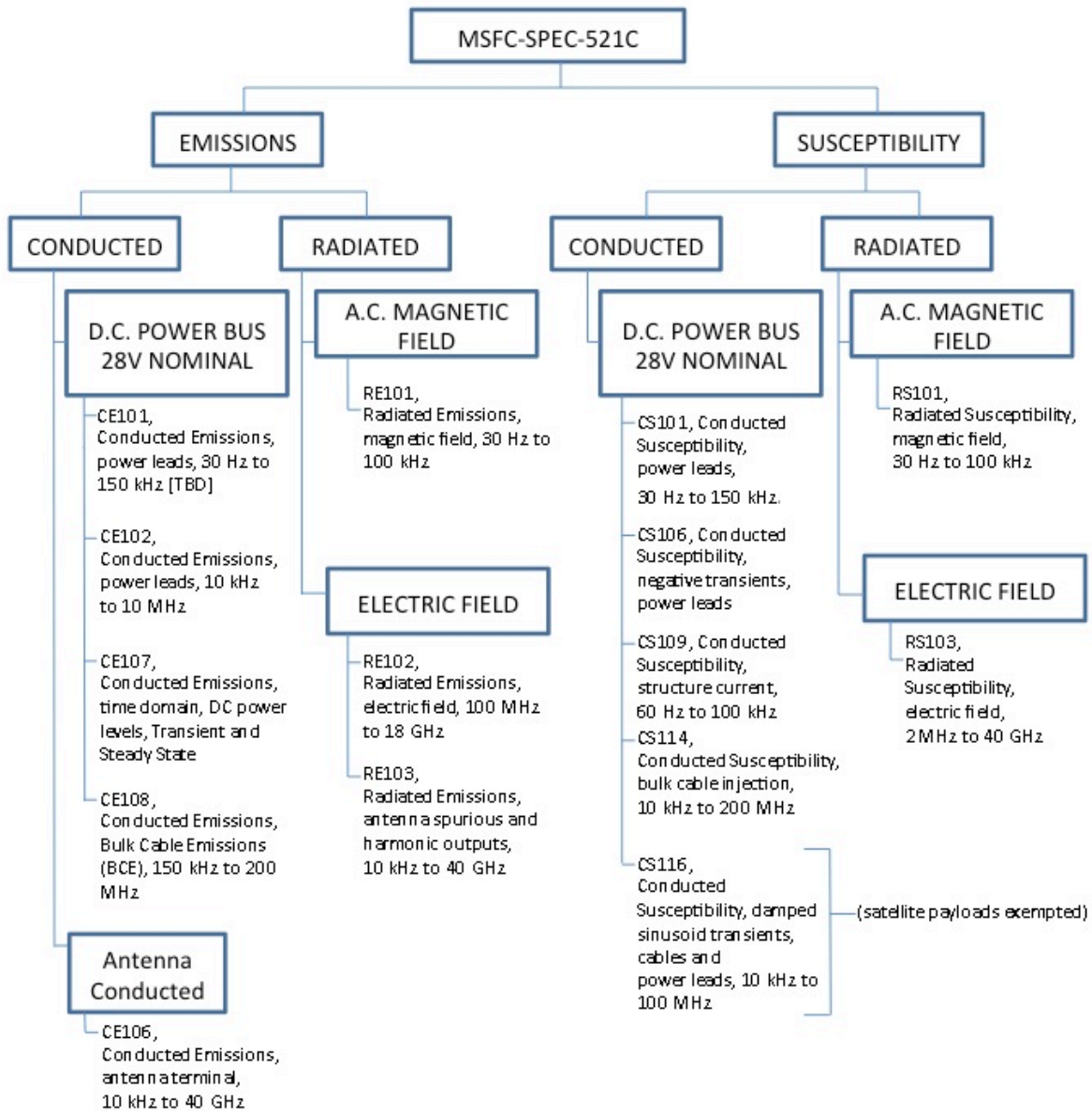

FIGURE 1. MSFC-SPEC-521C TEST SUMMARY CHART

3.3.1 Equipment Produced Emission

Conducted and radiated emissions produced by payload equipment shall be controlled as follows.

3.3.1.1 Conducted Emissions (CE)

3.3.1.1.1 DC Power Bus Ripple (CE101)

CHECK THE MASTER LIST VERIFY THAT THIS IS THE CORRECT VERSION BEFORE USE at <https://repository.msfc.nasa.gov/docs/multiprogram/MSFC-SPEC-521>

MSFC Technical Standard ES42		
Title: Electromagnetic Compatibility Requirements for Equipment and Subsystems	Document No.: MSFC-SPEC-521	Revision: C
	Effective Date: July 1, 2013	Page 17 of 75

This requirement is applicable from 30 Hz to 150 kHz for all primary power leads, including returns, which obtain power from other sources not part of the EUT.

3.3.1.1.1.1 CE101 Limits

Conducted emissions on power leads shall not exceed the applicable values shown in Figure 2 for 28 Volts Direct Current (Vdc) applications and Figure 3 for 120 Vdc applications.

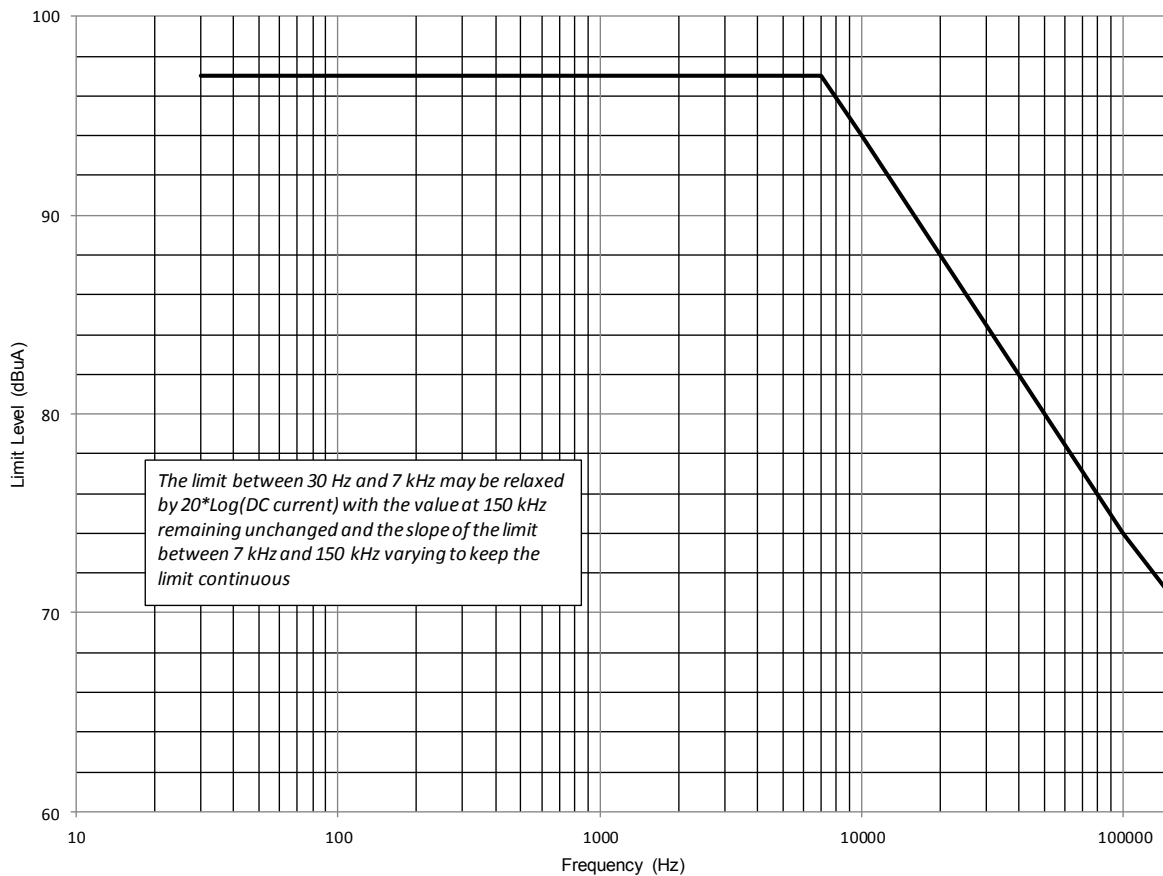

Figure 2. CE101 Limit for 28-volt applications, DC

MSFC Technical Standard ES42		
Title: Electromagnetic Compatibility Requirements for Equipment and Subsystems	Document No.: MSFC-SPEC-521	Revision: C
	Effective Date: July 1, 2013	Page 18 of 75

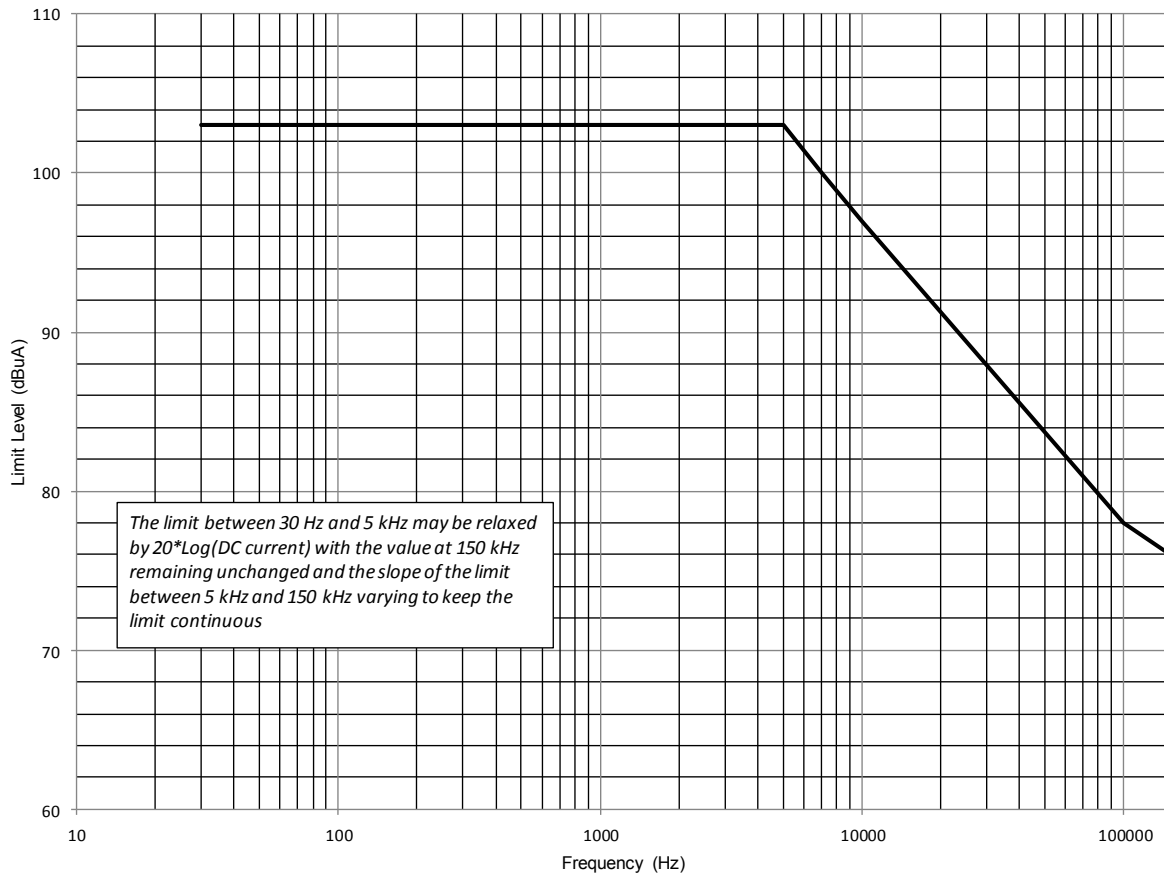

Figure 3. CE101 Limit for 120-volt applications, DC

3.3.1.1.2 DC Power Bus RF (CE102)

This requirement is applicable from 150 kHz to 10 MHz for all primary power leads, including returns, which obtain power from other sources not part of the EUT.

3.3.1.1.2.1 CE102 Limits

Conducted emissions on power leads shall not exceed the applicable values shown in Figure 4 for 28 Vdc applications and Figure 5 for 120 Vdc applications.

MSFC Technical Standard ES42		
Title: Electromagnetic Compatibility Requirements for Equipment and Subsystems	Document No.: MSFC-SPEC-521	Revision: C
	Effective Date: July 1, 2013	Page 19 of 75

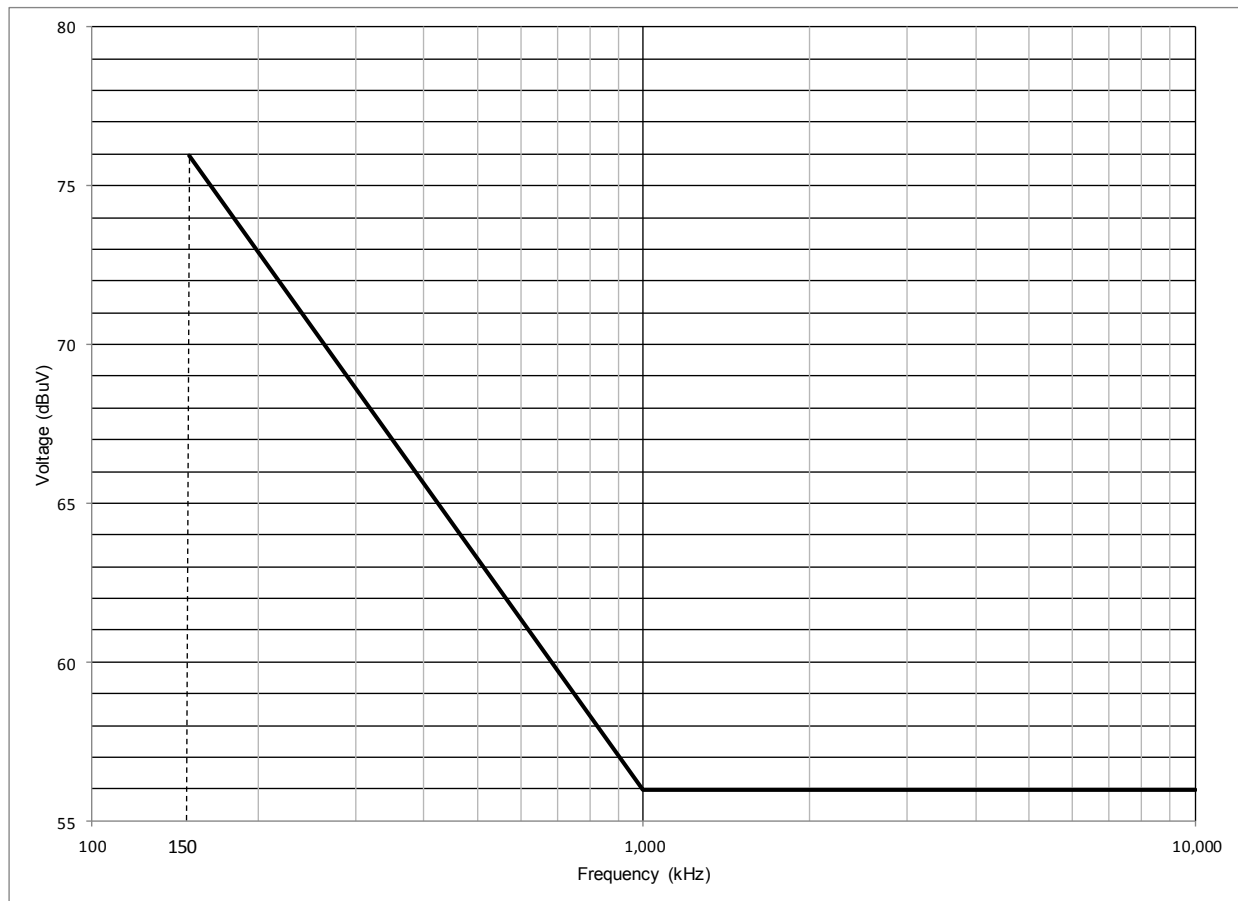

Figure 4. CE102 Limit for 28-volt applications, DC

MSFC Technical Standard ES42		
Title: Electromagnetic Compatibility Requirements for Equipment and Subsystems	Document No.: MSFC-SPEC-521	Revision: C
	Effective Date: July 1, 2013	Page 20 of 75

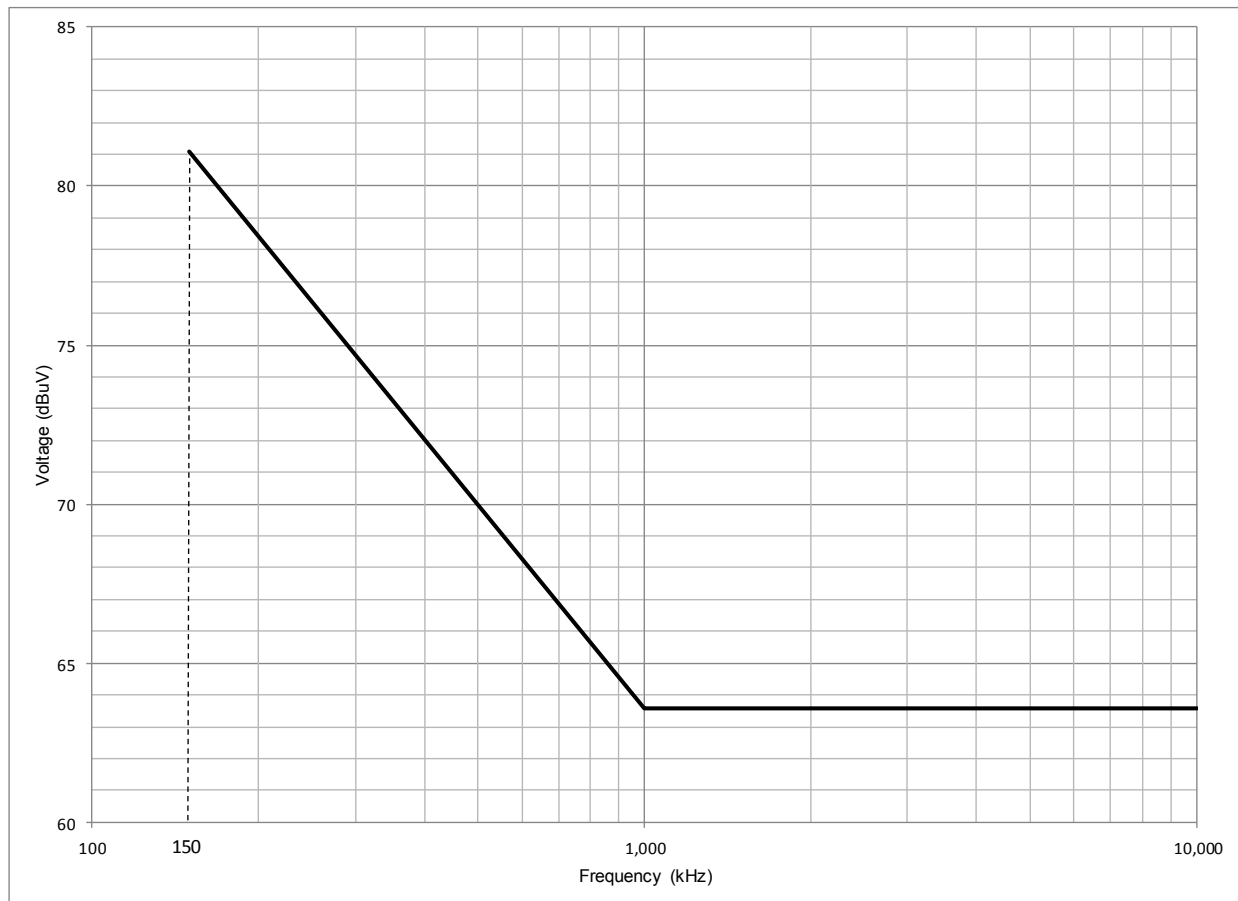

Figure 5. CE102 Limit for 120-volt applications, DC

3.3.1.1.3 Conducted Emissions, antenna terminal, 10 kHz to 40 Gigahertz (GHz) (CE106)

This requirement is applicable to the antenna terminals of transmitters, receivers, and amplifiers. The requirement is not applicable to equipment designed with antennas permanently mounted to the EUT. The transmit mode portion of this requirement is not applicable within the EUT necessary bandwidth and within $\pm 5\%$ of the fundamental frequency. Depending on the operating frequency range of the EUT, the start frequency of the test is shown below.

Operating Frequency Range (EUT)	Start Frequency of Test
3 MHz – 300 MHz	100 kHz
300 MHz – 3 GHz	1 MHz
3 GHz – 40 GHz	10 MHz

Note: The end frequency of the test is 40 GHz or 20 times the highest generated or received frequency within the EUT, whichever is less. For equipment using waveguide, the requirement does not apply below eight-tenths of the waveguide's cutoff frequency. Radiated Emission

CHECK THE MASTER LIST VERIFY THAT THIS IS THE CORRECT VERSION BEFORE USE at

<https://repository.msfc.nasa.gov/docs/multiprogram/MSFC-SPEC-521>

MSFC Technical Standard ES42		
Title: Electromagnetic Compatibility Requirements for Equipment and Subsystems	Document No.: MSFC-SPEC-521	Revision: C
	Effective Date: July 1, 2013	Page 21 of 75

(RE)103 may be used as an alternative for CE106 for testing transmitters with their operational antennas. RE102 is applicable for emissions from antennas in receive and standby modes and designed with antennas permanently mounted to the EUT.

3.3.1.1.3.1 CE106 Limits

Conducted emissions at the EUT antenna terminal shall not exceed the values given below.

- a. Receivers: 34 Decibel microvolts (dB μ V).
- b. Transmitters and amplifiers (standby mode): 34 dB μ V.
- c. Transmitters and amplifiers (transmit mode): Harmonics and all other spurious emissions, except the second and third harmonics, shall be at least 80 dB down from the level at the fundamental. The second and third harmonics shall be suppressed to a level of -20 decibels to one Milliwatt (dBm) or 80 dB below the fundamental, whichever requires less suppression.

3.3.1.1.4 Conducted Emissions, time domain, DC power levels, Transient and Steady State (CE107)

The requirement is applicable for measurement of all turn-on and mode-switching transients.

3.3.1.1.4.1 CE107 Limits

Transient emissions on power leads shall not exceed the applicable values shown in Figure 6 for 28 Vdc applications and Figure 7 for 120 Vdc applications.

MSFC Technical Standard ES42		
Title: Electromagnetic Compatibility Requirements for Equipment and Subsystems	Document No.: MSFC-SPEC-521	Revision: C
	Effective Date: July 1, 2013	Page 22 of 75

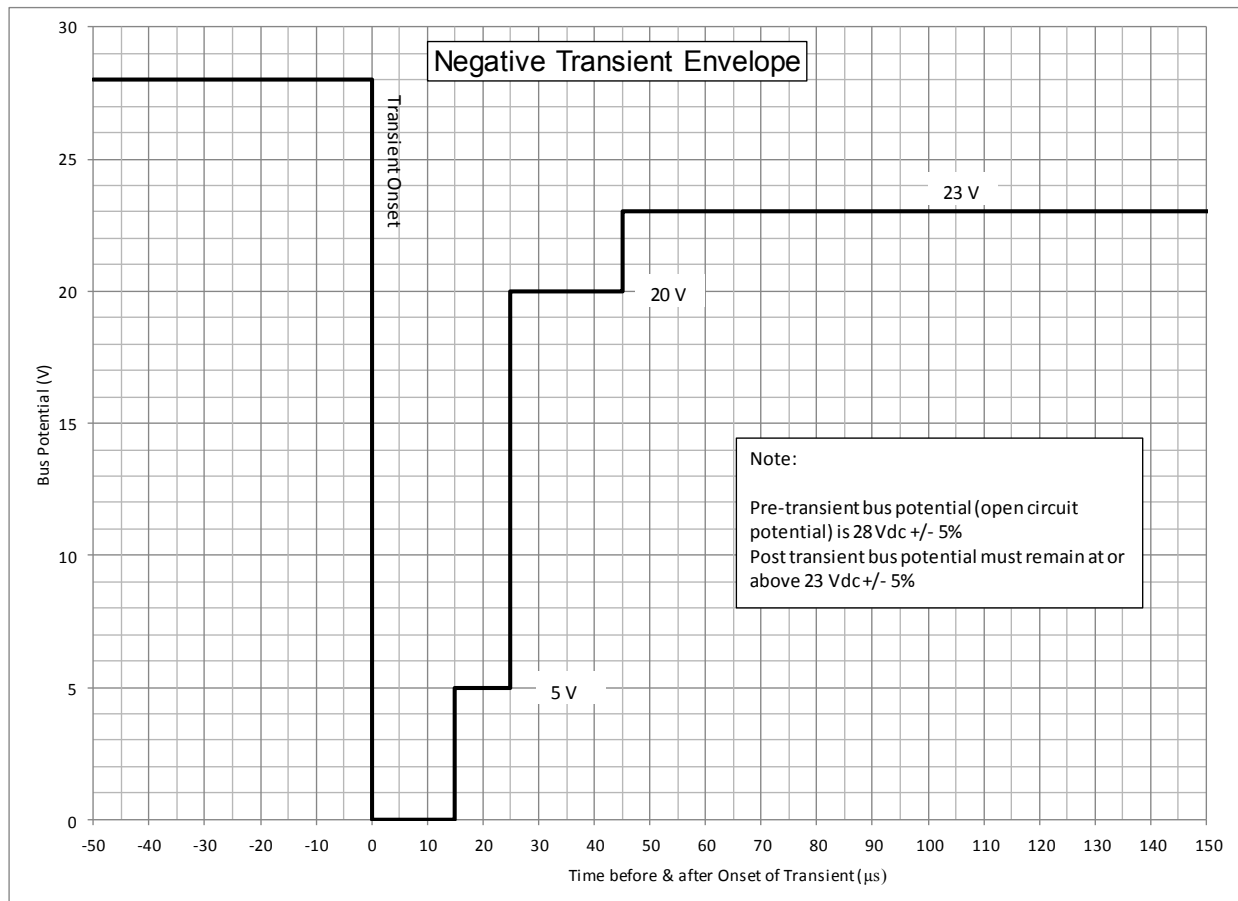

Figure 6. CE107 Power source transient excursion limit for 28 Vdc applications

MSFC Technical Standard ES42		
Title: Electromagnetic Compatibility Requirements for Equipment and Subsystems	Document No.: MSFC-SPEC-521	Revision: C
	Effective Date: July 1, 2013	Page 23 of 75

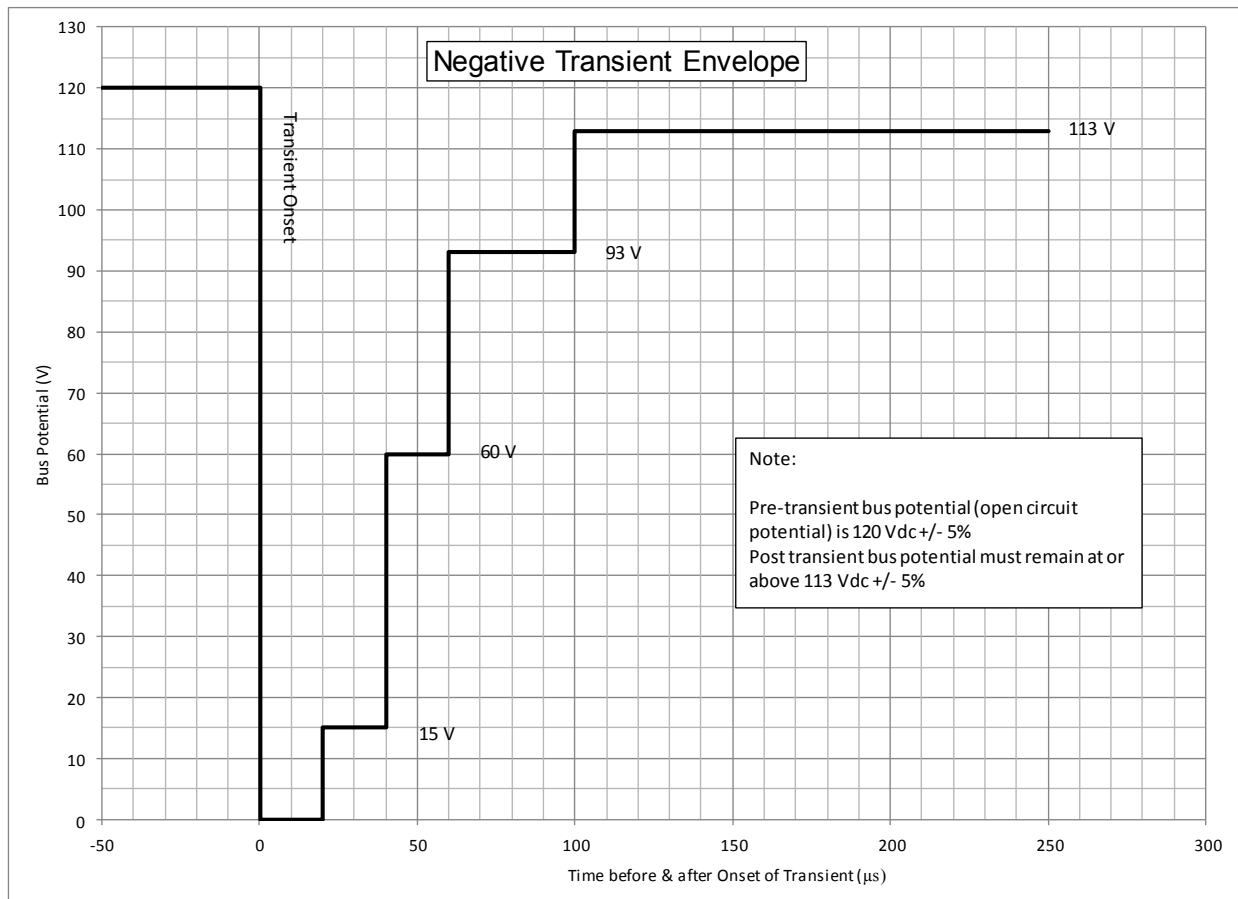

Figure 7. CE107 Power source transient excursion limit for 120 Vdc applications

3.3.1.1.5 Conducted Emissions, Bulk Cable Emissions (BCE), 150 kHz to 200 MHz (CE108)

This requirement is applicable for equipment and subsystem interconnecting cables. The requirement does not apply at the transmitter fundamental frequencies.

3.3.1.1.5.1 CE108 Limits

BCE shall not exceed the values shown in Figure 8.

MSFC Technical Standard ES42		
Title: Electromagnetic Compatibility Requirements for Equipment and Subsystems	Document No.: MSFC-SPEC-521	Revision: C
	Effective Date: July 1, 2013	Page 24 of 75

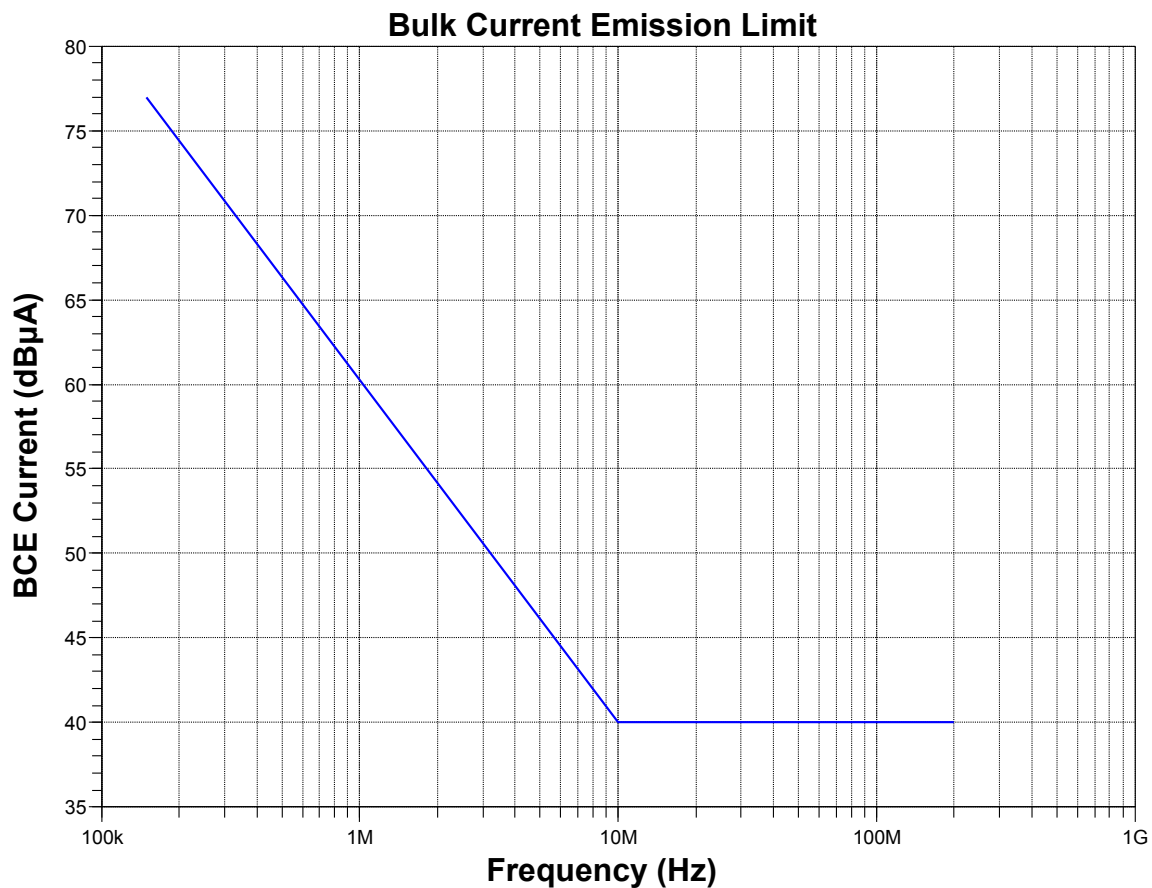

Figure 8. CE108 BCE limit for all applications

3.3.1.2 Radiated Emissions (RE)

3.3.1.2.1 Radiated Emissions, magnetic field, 30 Hz to 100 kHz (RE101)

This requirement is specialized and is intended primarily to control magnetic fields for applications in which equipment is present in the installation that is potentially sensitive to magnetic induction at lower frequencies. The most common example is a tuned receiver that operates within the frequency range of the test.

3.3.1.2.1.1 RE101 Limits

Equipment containing devices that intentionally generate magnetic fields (electromagnets) shall not generate AC magnetic fields that exceed the levels in the table below. This requirement

MSFC Technical Standard ES42		
Title: Electromagnetic Compatibility Requirements for Equipment and Subsystems	Document No.: MSFC-SPEC-521	Revision: C
	Effective Date: July 1, 2013	Page 25 of 75

applies at a distance of 7 centimeters (cm) from a point on the enclosure of the equipment case nearest the source of the field.

Frequency	Magnitude (dBpT)
30 Hz	140
30 Hz to 3.5 kHz	Falling 26.5 dB/decade from 140 to 85
3.5 kHz to 50 kHz	85

Note: Requirements are not applicable to solenoid valves, solenoid relays, and electric motors with current of less than 1 Amp.

The Radiated Susceptibility (RS)101 limits are higher to allow for variations in performance between manufactured items and to account for the possibility that the emissions from the EUT may couple into a larger physical area than that evaluated under the RS101 test procedures.

An estimate can be made of the types of induced levels that will result in circuitry from the limits. Magnetic fields act by inducing voltages into loop areas in accordance with Faraday's law ($V = -d\phi/dt$). For a uniform magnetic field perpendicular to the loop area, the induced voltage from Faraday's law reduces to $V = -2\pi fBA$.

f = Frequency of Interest B = Magnetic Flux Density A = Loop Area

3.3.1.2.2 Radiated Emissions, electric field, 200 MHz to 40 GHz (RE102)

This requirement is applicable for radiated emissions from equipment and subsystem enclosures, all interconnecting cables, and antennas designed to be permanently mounted to EUTs (receivers and transmitters in standby mode). The requirement does not apply at the transmitter fundamental frequencies. The requirement is applicable between 200 MHz to 40 GHz.*

* Testing is required up to 1 GHz or ten times the highest intentionally generated frequency within the EUT, whichever is greater. Measurements beyond 40 GHz are not required.

3.3.1.2.2.1 RE102 Limits

Electric field emissions shall not be radiated in excess of those shown in Figure 9. The limits shall be met for both horizontally and vertically polarized fields.

MSFC Technical Standard ES42		
Title: Electromagnetic Compatibility Requirements for Equipment and Subsystems	Document No.: MSFC-SPEC-521	Revision: C
	Effective Date: July 1, 2013	Page 26 of 75

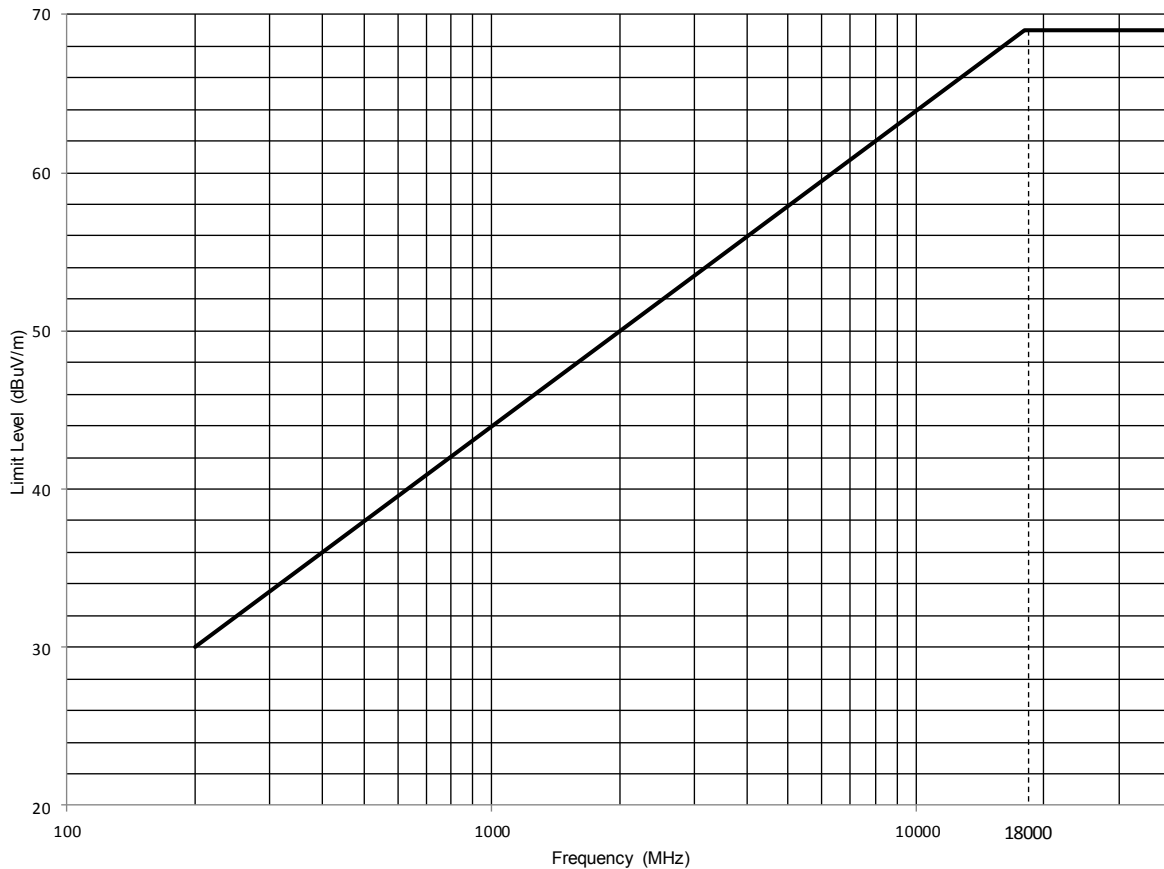

Figure 9. RE102 Limit for all applications

3.3.1.2.3 Radiated Emissions, antenna spurious and harmonic outputs, 100 kHz to 40 GHz (RE103)

This requirement may be used as an alternative for CE106 when testing transmitters with their intended antennas. This requirement is met if the emissions do not exceed the applicable RE102 limit. CE106 is the preferred requirement unless the equipment or subsystem design characteristics preclude its use. The requirement is not applicable within the EUT necessary bandwidth and within $\pm 5\%$ of the fundamental frequency. Depending on the operating frequency range of the EUT, the start frequency of the test is as follows:

Operating Frequency Range (EUT)	Start Frequency of Test
3 MHz – 300 MHz	100 kHz
300 MHz – 3 GHz	1 MHz
3 GHz – 40 GHz	10 MHz

MSFC Technical Standard ES42		
Title: Electromagnetic Compatibility Requirements for Equipment and Subsystems	Document No.: MSFC-SPEC-521	Revision: C
	Effective Date: July 1, 2013	Page 27 of 75

Note: The end frequency of the test is 40 GHz or 20 times the highest generated frequency within the EUT, whichever is less. For equipment using waveguide, the requirement does not apply below eight-tenths of the waveguide's cutoff frequency.

3.3.1.2.3.1 RE103 Limits

Harmonics, except the second and third, and all other spurious emissions shall be at least 80 dB down from the level at the fundamental. The second and third harmonics shall be suppressed $50 + 10 \log p$ (where p = peak power output in watts, at the fundamental) or 80 dB, whichever requires less suppression.

3.3.2 Equipment Susceptibility

Equipment shall not malfunction or exhibit degraded performance beyond the tolerance given in the individual equipment specification when subjected to the following electromagnetic environment.

3.3.2.1 Conducted Susceptibility (CS)

3.3.2.1.1 Conducted Susceptibility, power leads, 30 Hz to 150 kHz (CS101)

This requirement is applicable to equipment and subsystem DC input power leads, not including returns. This requirement is applicable over the frequency range of 30 Hz to 150 kHz.

3.3.2.1.1.1 CS101 Limits

The EUT shall not exhibit any malfunction, degradation of performance, or deviation from specified indications, beyond the tolerances indicated in the individual equipment or subsystem specification, when subjected to a test signal with voltage levels as specified in Figure 10 for 28 Vdc applications and Figure 11 for 120 Vdc applications. The requirement is also met when the power source is adjusted to dissipate the power level shown in Figure 12 (for 28Vdc applications) or Figure 13 (for 120 Vdc applications) in a 0.5-Ω load and the EUT is not susceptible.

MSFC Technical Standard ES42		
Title: Electromagnetic Compatibility Requirements for Equipment and Subsystems	Document No.: MSFC-SPEC-521	Revision: C
	Effective Date: July 1, 2013	Page 28 of 75

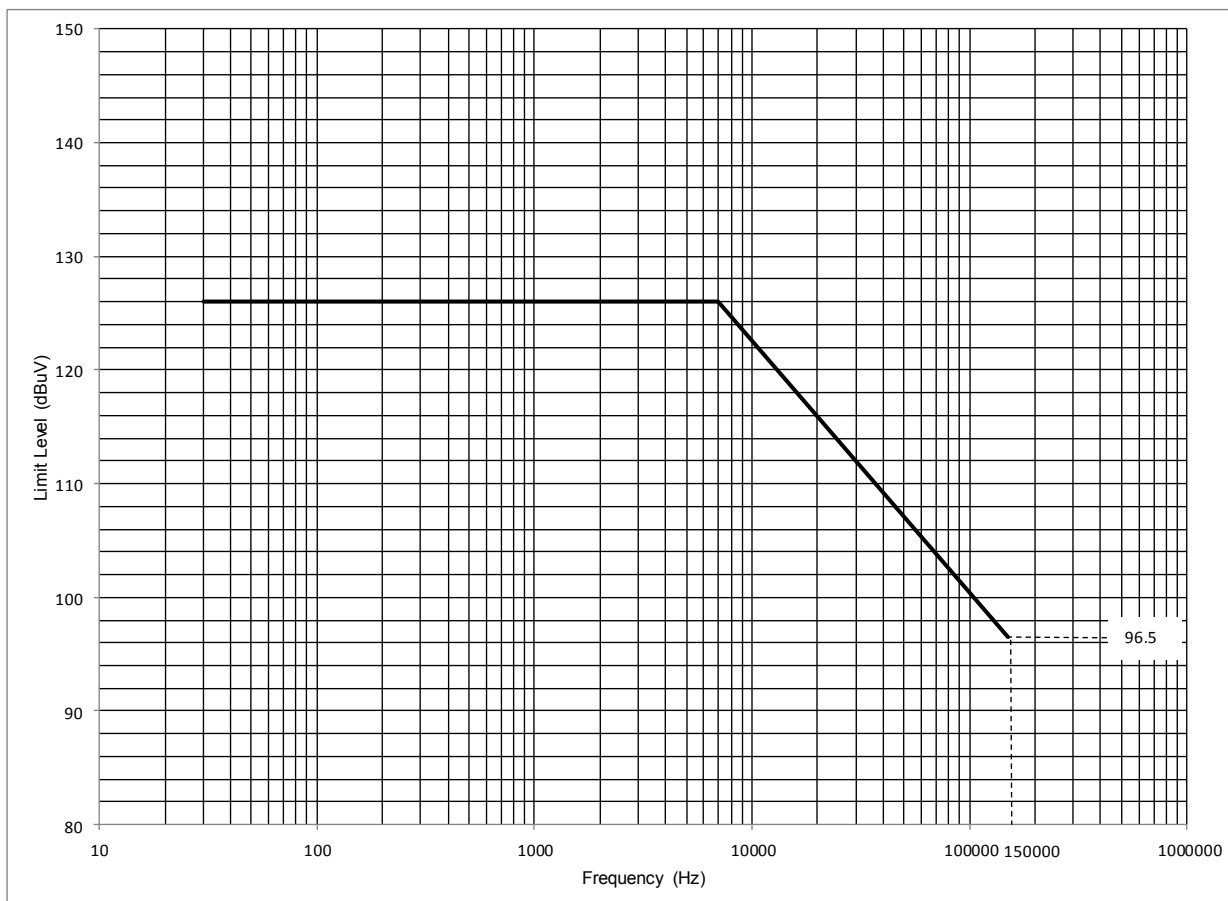

Figure 10. CS101 Voltage limit for 28 Vdc applications

MSFC Technical Standard ES42		
Title: Electromagnetic Compatibility Requirements for Equipment and Subsystems	Document No.: MSFC-SPEC-521	Revision: C
	Effective Date: July 1, 2013	Page 29 of 75

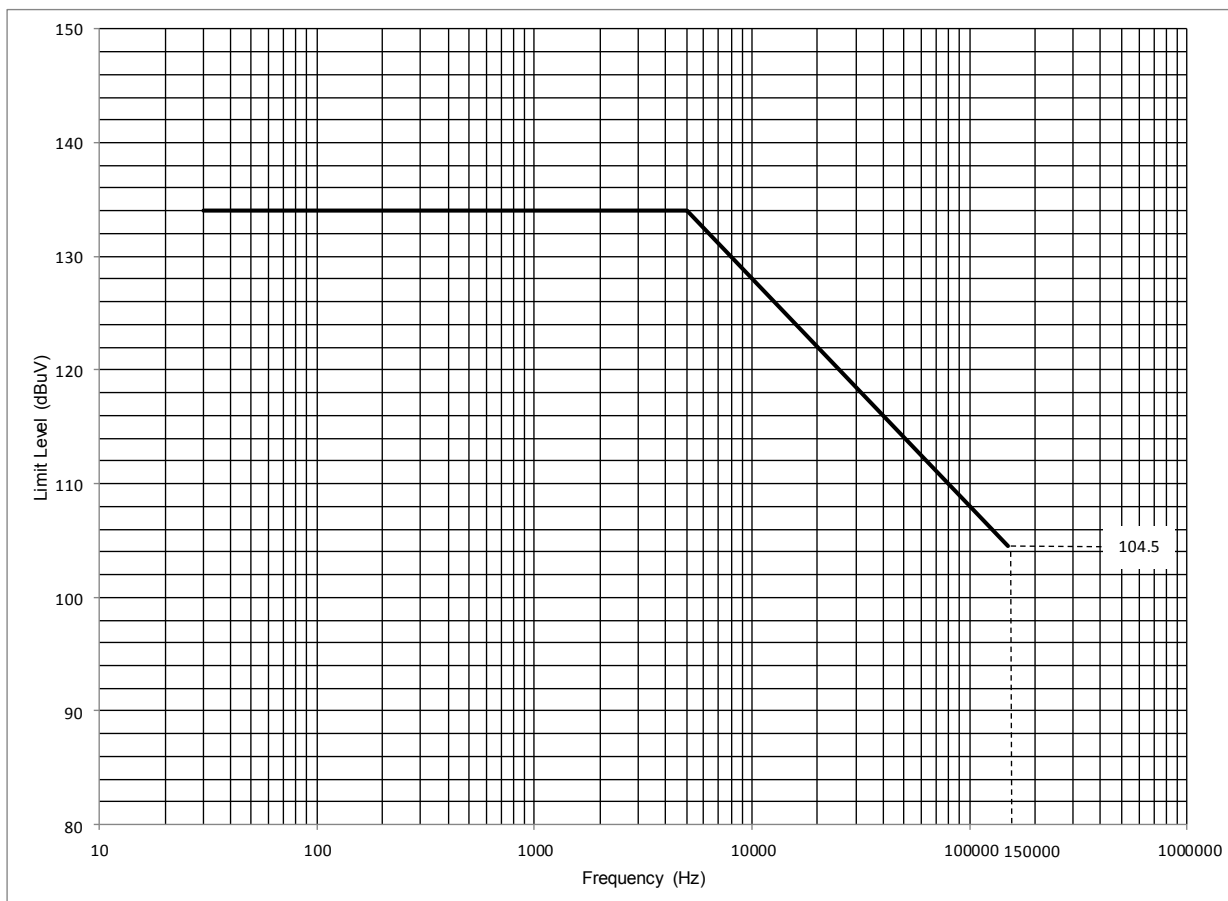

Figure 11. CS101 Voltage limit for 120 Vdc applications

MSFC Technical Standard ES42		
Title: Electromagnetic Compatibility Requirements for Equipment and Subsystems	Document No.: MSFC-SPEC-521	Revision: C
	Effective Date: July 1, 2013	Page 30 of 75

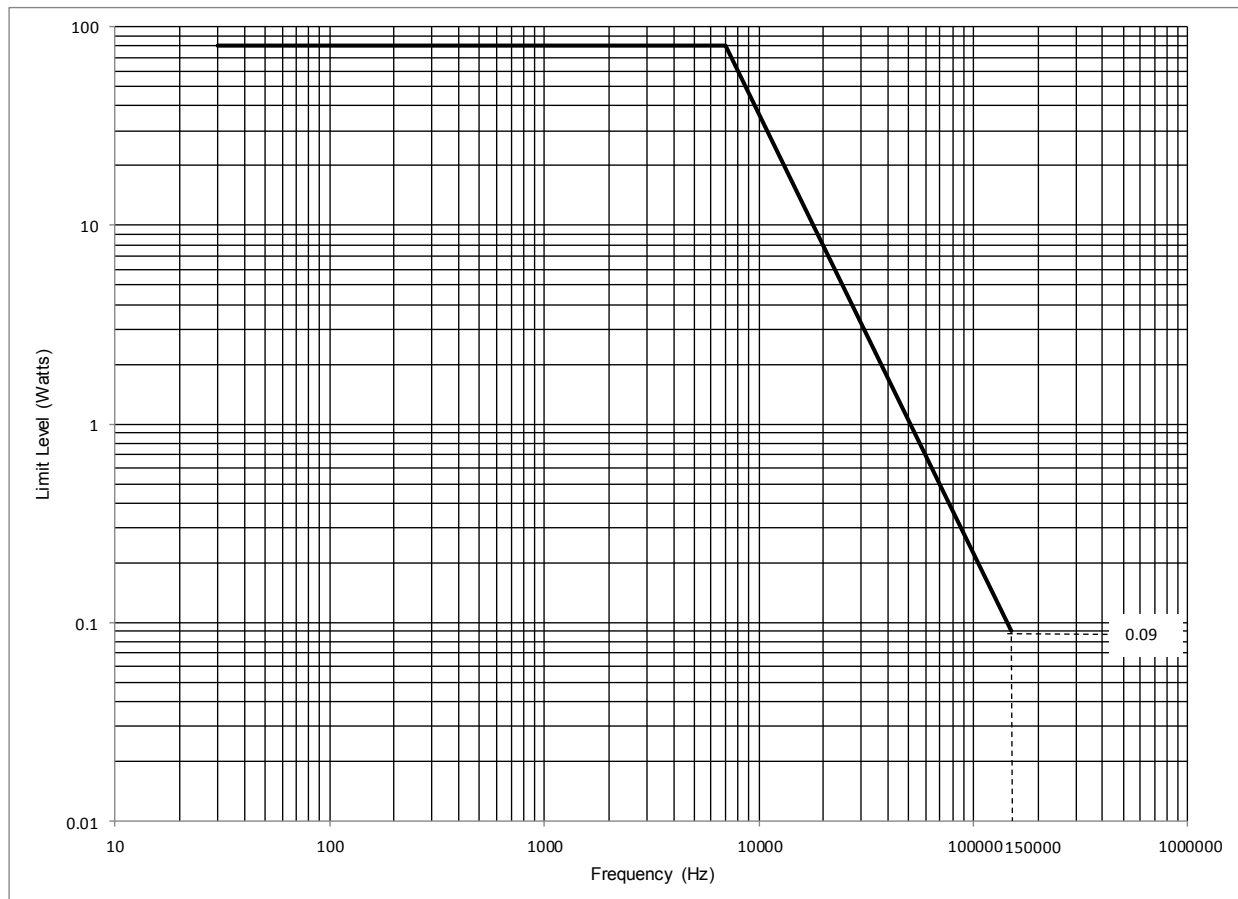

Figure 12. CS101 Power limit for 28 Vdc applications

MSFC Technical Standard ES42		
Title: Electromagnetic Compatibility Requirements for Equipment and Subsystems	Document No.: MSFC-SPEC-521	Revision: C
	Effective Date: July 1, 2013	Page 31 of 75

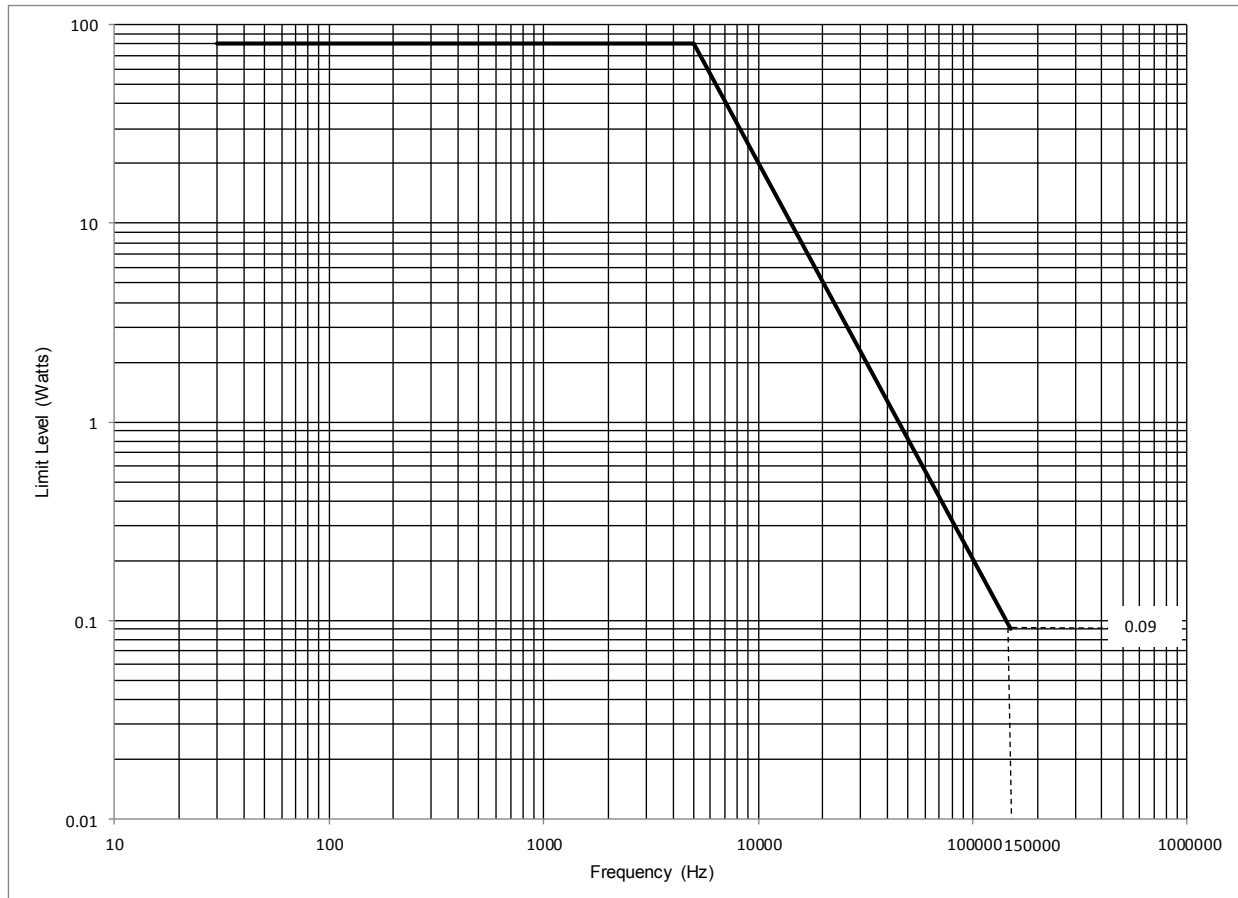

Figure 13. CS101 Power limit for 120 Vdc applications

3.3.2.1.2 Conducted Susceptibility, negative transients, power leads (CS106)

This requirement is applicable to equipment and subsystem DC input power leads, not including returns.

Note: This is not the same test as MIL-STD-461F CS106, which uses a different transient waveform and is not applicable for space applications.

3.3.2.1.2.1 CS106 Limits

The EUT shall not exhibit any malfunction, degradation of performance, or deviation from specified indications, beyond the tolerances indicated in the individual equipment or subsystems specification, when subjected to a pre-calibrated transient having pulse width and amplitude as

MSFC Technical Standard ES42		
Title: Electromagnetic Compatibility Requirements for Equipment and Subsystems	Document No.: MSFC-SPEC-521	Revision: C
	Effective Date: July 1, 2013	Page 32 of 75

specified in Figure 14 for 28 Vdc applications or Figure 15 for 120 Vdc applications at a 1-Hz rate for 1 minute (min).

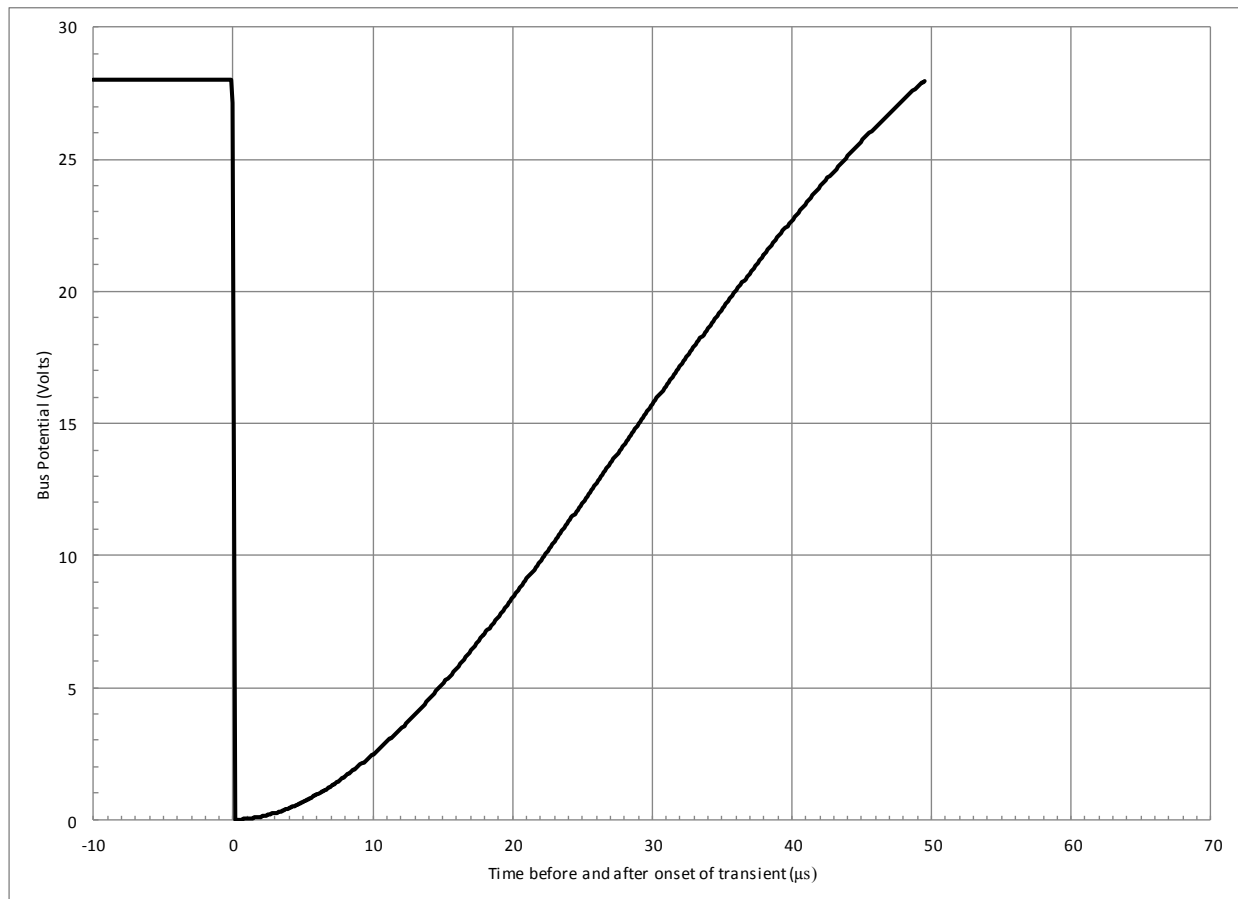

Figure 14. CS106 Transients envelope for 28 Vdc applications

MSFC Technical Standard ES42		
Title: Electromagnetic Compatibility Requirements for Equipment and Subsystems	Document No.: MSFC-SPEC-521	Revision: C
	Effective Date: July 1, 2013	Page 33 of 75

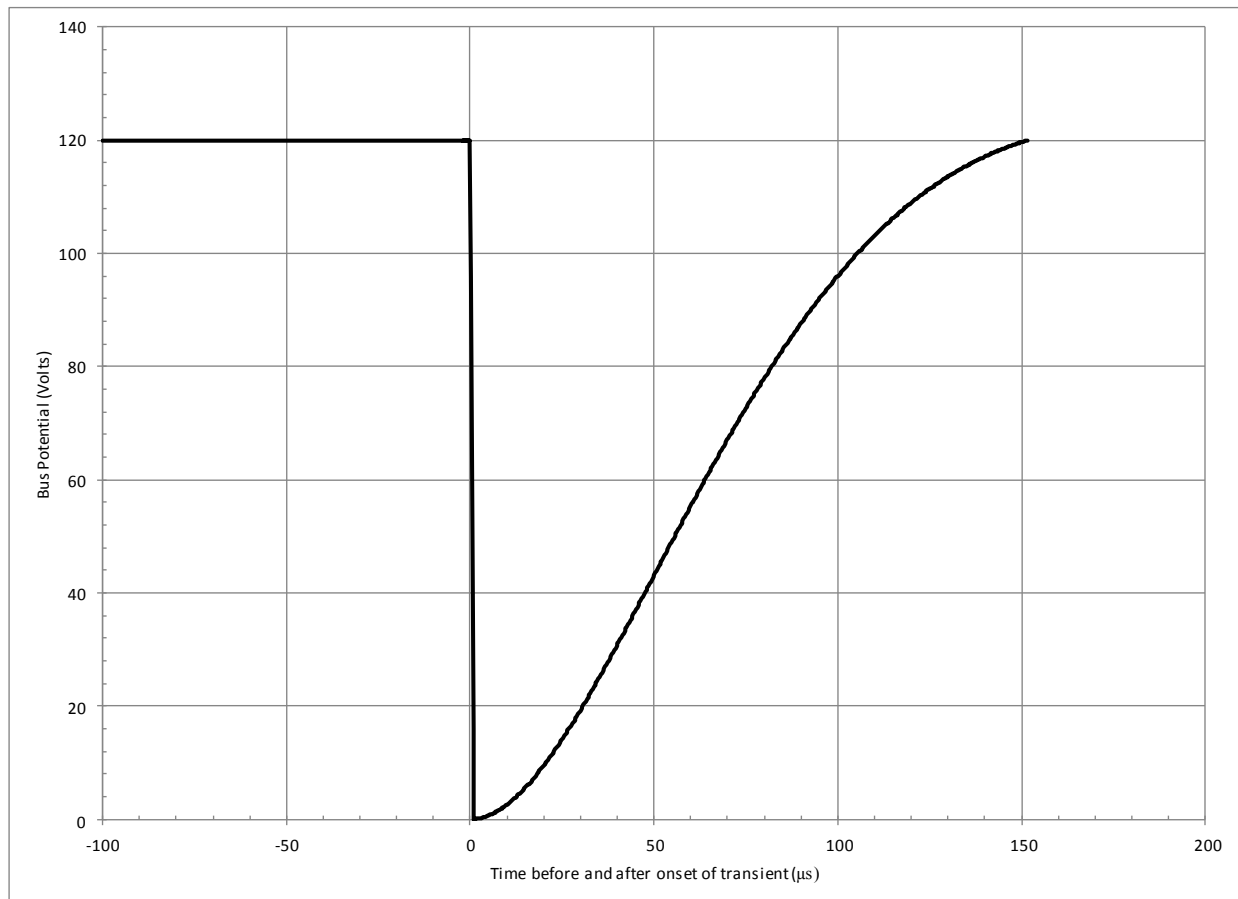

Figure 15. CS106 Transients envelope for 120 Vdc applications

3.3.2.1.3 Conducted Susceptibility, structure current, 60 Hz to 100 kHz (CS109)

This requirement is applicable to equipment and subsystems that have an operating frequency of 100 kHz or less and an operating sensitivity of 1 μ V or better (such as 0.5 μ V). Handheld equipment is exempt from this requirement.

3.3.2.1.3.1 CS109 Limits

The EUT shall not exhibit any malfunction, degradation of performance, or deviation from specified indications, beyond the tolerances indicated in the individual equipment or subsystem specification, when subjected to the injected current values shown on Figure 16.

MSFC Technical Standard ES42		
Title: Electromagnetic Compatibility Requirements for Equipment and Subsystems	Document No.: MSFC-SPEC-521	Revision: C
	Effective Date: July 1, 2013	Page 34 of 75

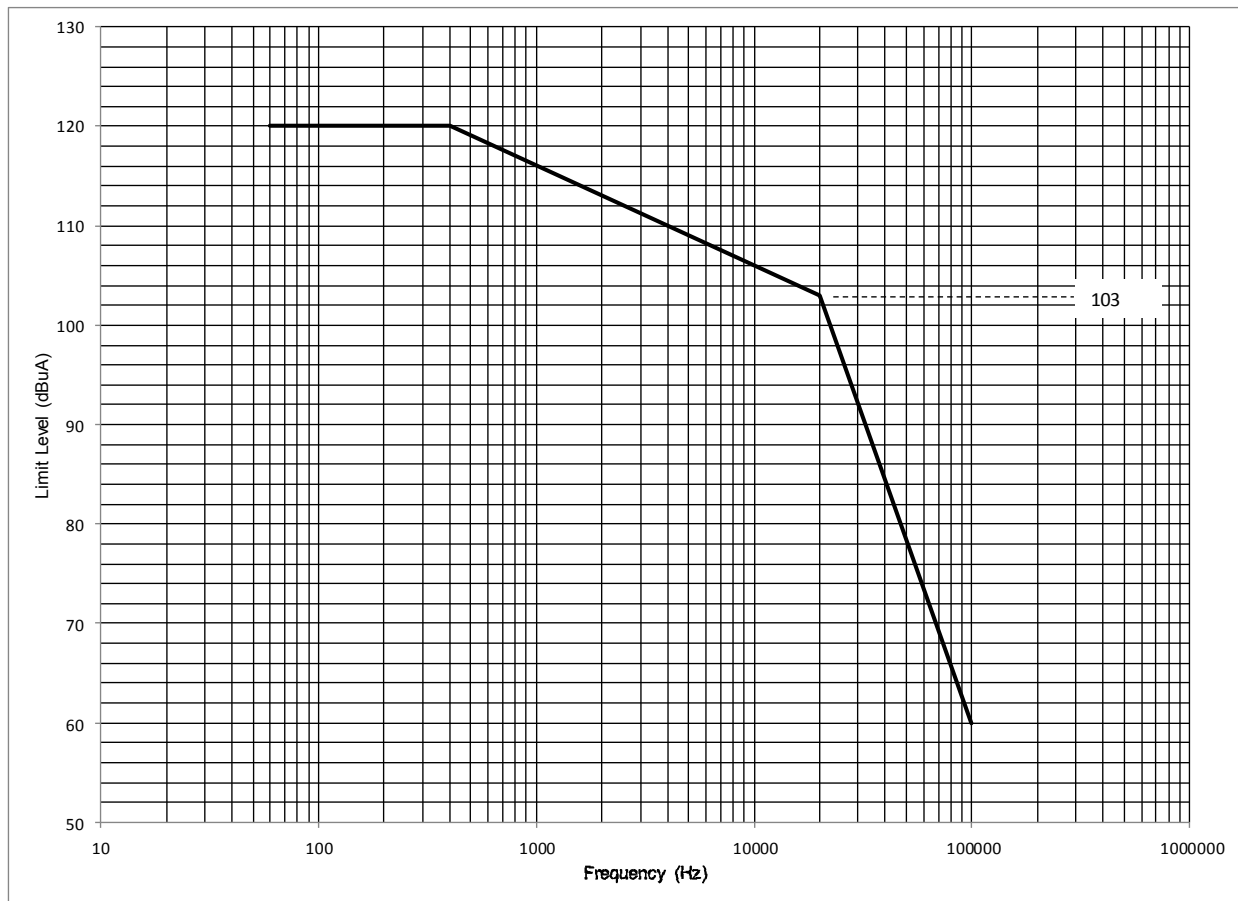

Figure 16. CS109 Current Limit for all applications

3.3.2.1.4 Conducted Susceptibility, bulk cable injection, 10 kHz to 200 MHz (CS114)

This requirement is applicable to all interconnecting cables, including power cables.

3.3.2.1.4.1 CS114 Limits

The EUT shall not exhibit any malfunction, degradation of performance, or deviation from specified indications beyond the tolerances indicated in the individual equipment or subsystem specification, when subjected to an injection probe drive level that has been pre-calibrated to the appropriate current limit shown in Figure 17. Requirements are also met if the EUT is not susceptible at forward power levels sensed by the coupler that are below those determined during calibration provided that the actual current induced in the cable under test (CUT) is 6 dB or greater than the calibration limit.

MSFC Technical Standard ES42		
Title: Electromagnetic Compatibility Requirements for Equipment and Subsystems	Document No.: MSFC-SPEC-521	Revision: C
	Effective Date: July 1, 2013	Page 35 of 75

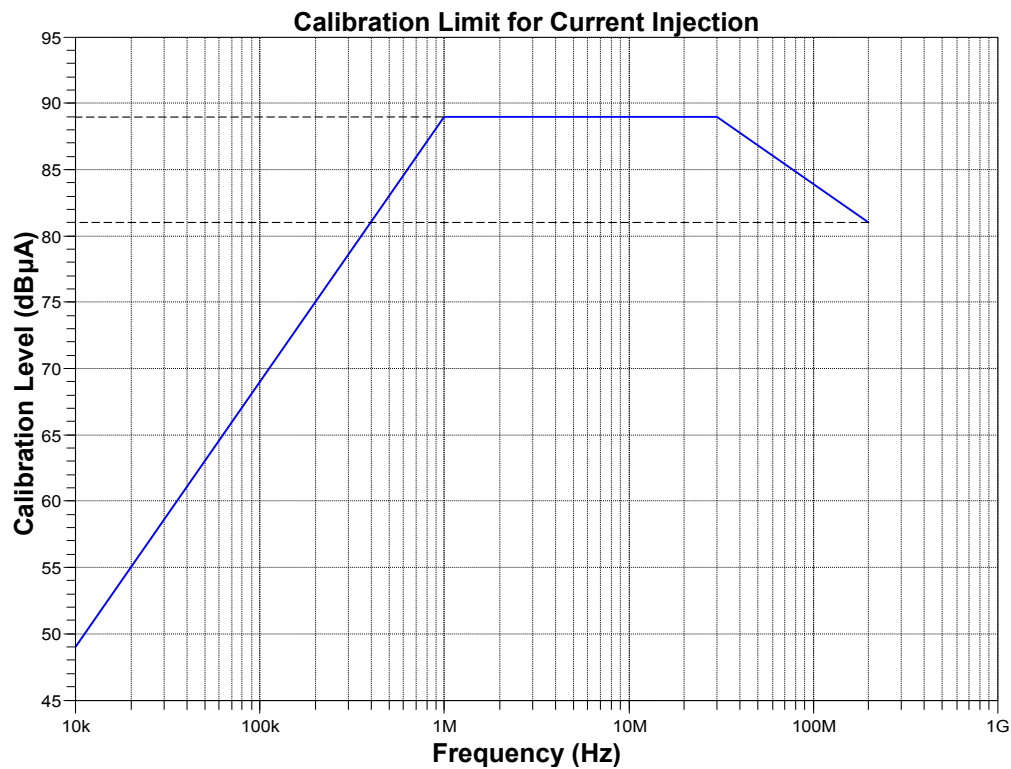

Figure 17. CS114 Calibration limit for all applications

3.3.2.1.5 Conducted Susceptibility, damped sinusoid transients, cables and power leads, 10 kHz to 100 MHz (CS116) [satellite payloads exempted]

This requirement is applicable to all interconnecting cables, including power cables, and individual high side power leads. Power returns and neutrals need not be tested individually.

3.3.2.1.5.1 CS116 Limits

The EUT shall not exhibit any malfunction, degradation of performance, or deviation from specified indications, beyond the tolerances indicated in the individual equipment or subsystem specification, when subjected to a signal having the waveform shown in Figure 18 and having a maximum current as specified in Figure 19. The limit is applicable across the entire specified frequency range. As a minimum, compliance shall be demonstrated at the following frequencies: 0.01, 0.1, 1, 10, 30, and 100 MHz. If there are other frequencies known to be critical to the equipment installation, such as platform resonances, compliance shall also be demonstrated at those frequencies. The test signal repetition rate shall be no greater than one pulse per second and no less than one pulse every two seconds. The pulses shall be applied for a period of five minutes.

MSFC Technical Standard ES42		
Title: Electromagnetic Compatibility Requirements for Equipment and Subsystems	Document No.: MSFC-SPEC-521	Revision: C
	Effective Date: July 1, 2013	Page 36 of 75

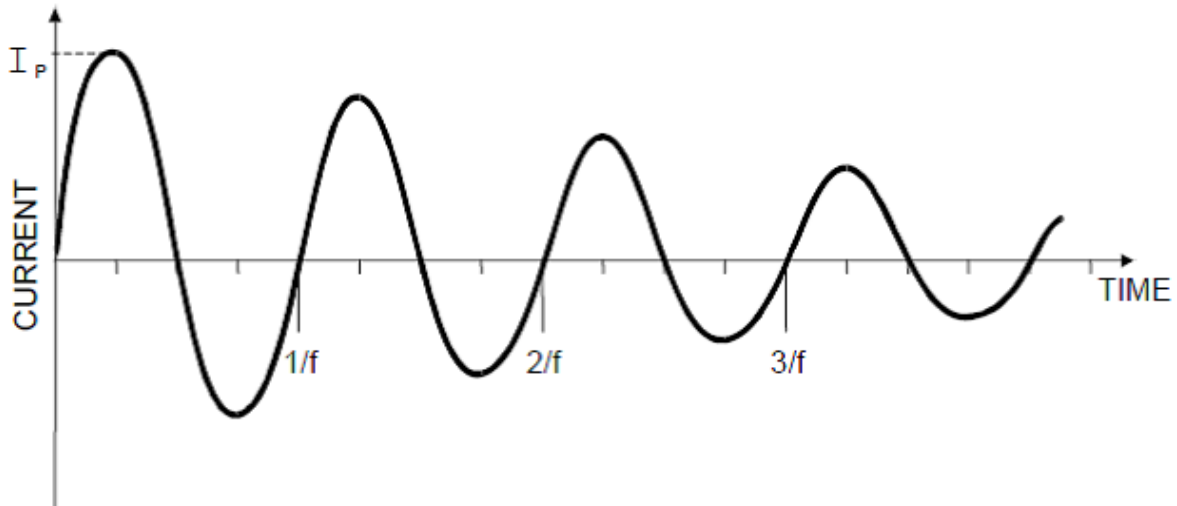

Figure 18. Typical CS116 damped sinusoidal waveform

Notes:

1. Normalized waveform: $e^{-(\pi ft)/Q} \sin(2\pi ft)$

Where:

f = Frequency (Hz)

t = Time (sec)

Q = Damping factor, 15 ± 5

2. Damping factor (Q) shall be determined as follows:

$$Q = \frac{\pi(N - 1)}{\ln(I_P/I_N)}$$

Where:

Q = Damping factor

N = Cycle number (i.e. N = 2, 3, 4, 5,...)

I_P = Peak current at 1st cycle

I_N = Peak current at cycle closest to 50% decay

ln = Natural log

3. I_P as specified in Figure 19.

MSFC Technical Standard ES42		
Title: Electromagnetic Compatibility Requirements for Equipment and Subsystems	Document No.: MSFC-SPEC-521	Revision: C
	Effective Date: July 1, 2013	Page 37 of 75

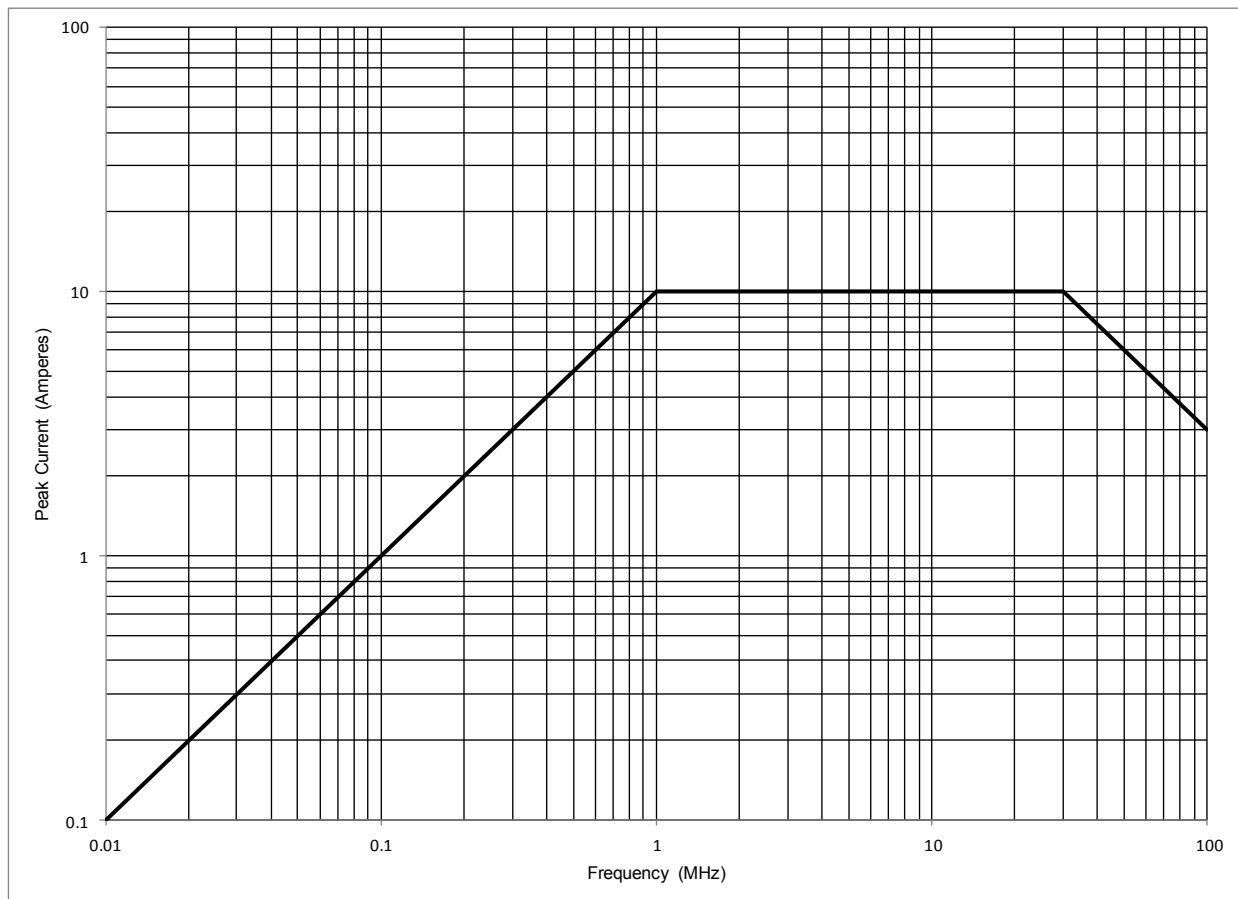

Figure 19. CS116 Limit

3.3.2.2 Radiated Susceptibility (RS)

3.3.2.2.1 Radiated Susceptibility, magnetic field, 30 Hz to 100 kHz (RS101)

This requirement is applicable to equipment and subsystem enclosures, including electrical cable interfaces. The requirement is not applicable for electromagnetic coupling via antennas.

3.3.2.2.1.1 RS101 Limits

The EUT shall not exhibit any malfunction, degradation of performance, or deviation from specified indications, beyond the tolerances indicated in the individual equipment or subsystem specification, when subjected to the magnetic fields shown in Figure 20.

MSFC Technical Standard ES42		
Title: Electromagnetic Compatibility Requirements for Equipment and Subsystems	Document No.: MSFC-SPEC-521	Revision: C
	Effective Date: July 1, 2013	Page 38 of 75

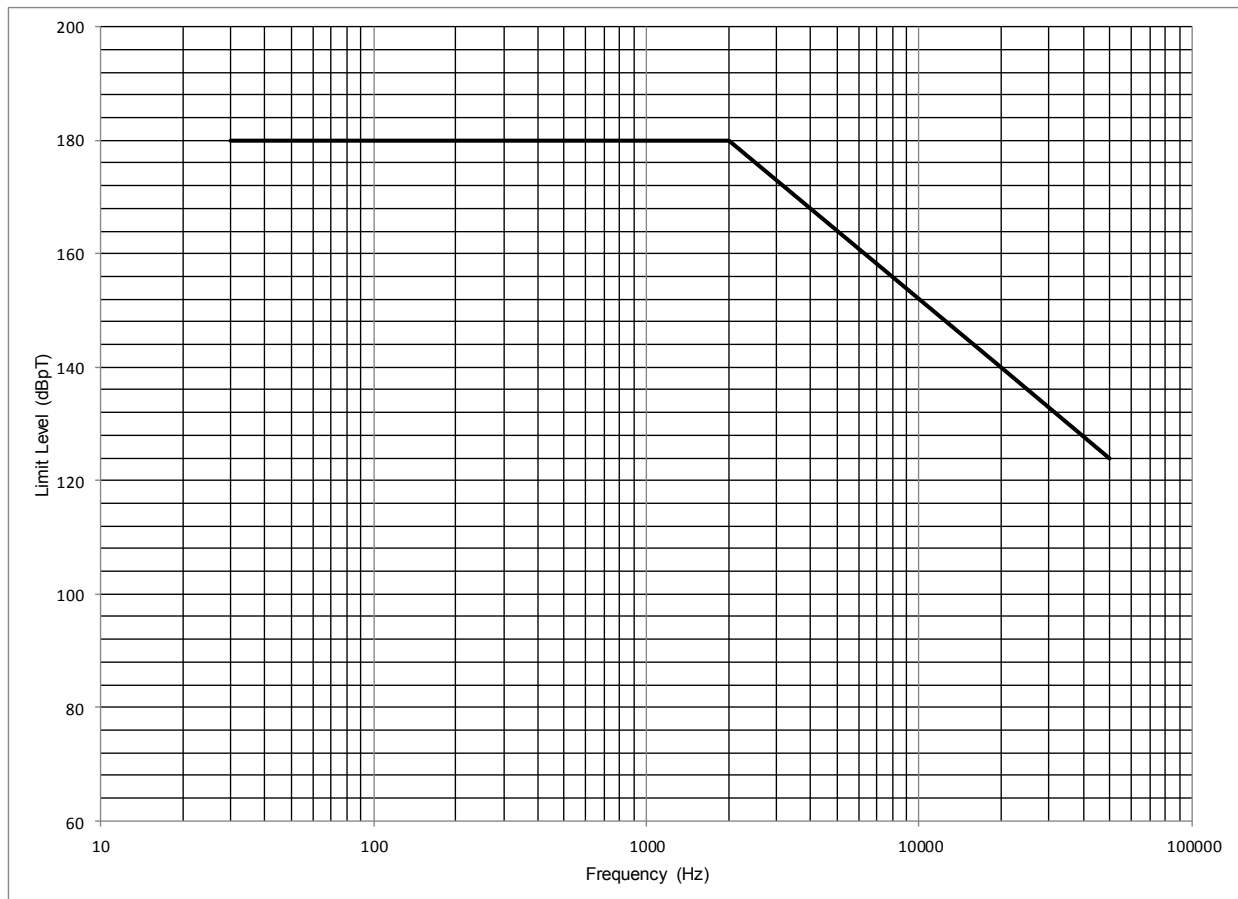

Figure 20. RS101 Test limit for all applications

3.3.2.2.2 Radiated Susceptibility, electric field, 200 MHz to 40 GHz (RS103)

This requirement is applicable to equipment and subsystem enclosures and all interconnecting cables.

Note: The requirement in the passband of an antenna-connected receiver is 20 dB above the RE102 limit associated with the particular platform application. The test should be performed with the antenna removed and antenna port terminated. Receivers with antennas permanently mounted to the EUT are exempt from testing in the receiver passband.

3.3.2.2.2.1 RS103 Limits

The EUT shall not exhibit any malfunction, degradation of performance, or deviation from specified indications, beyond the tolerances indicated in the individual equipment or subsystem specification, when subjected to the radiated electric fields listed in Table I and modulated as

CHECK THE MASTER LIST VERIFY THAT THIS IS THE CORRECT VERSION BEFORE USE at
<https://repository.msfc.nasa.gov/docs/multiprogram/MSFC-SPEC-521>

MSFC Technical Standard ES42		
Title: Electromagnetic Compatibility Requirements for Equipment and Subsystems	Document No.: MSFC-SPEC-521	Revision: C
	Effective Date: July 1, 2013	Page 39 of 75

specified below. Above 30 MHz, the requirement shall be met for both horizontally and vertically polarized fields. Circular polarized fields are not acceptable.

Table I. RS103 Limits

Frequency Range	Test Limit (V/m)	Applicability
200 MHz – 18 GHz	200	Applicable when platform or vehicle on which equipment will be installed is unknown or equipment is mounted externally
200 MHz – 18 GHz	20	Alternate test level. Applicable when platform or vehicle on which equipment will be installed provides greater than 20 dB of attenuation from outside electromagnetic environment
18 GHz – 40 GHz	20	Applicable when platform or vehicle on which equipment will be installed utilizes transmitters operating above 18 GHz

4.0 VERIFICATION

4.1 General

This section identifies activities required to verify that the requirements of Section 3 have been satisfied.

4.2 Verification methods

Equipment and subsystems shall be verified by analysis, demonstration, inspection, test, validation of records or similarity (or a combination thereof) as specified herein to assure compliance with Section 3. Definitions of verification methods are from Marshall Work Instruction MWI 8050.1, “Verification & Validation of Hardware, Software, and Ground Support Equipment for MSFC Projects.”

4.2.1 Analysis

Analysis (A) involves the use of engineering analysis, qualitative assessment, computer modeling and/or simulations to ensure compliance to the requirement(s). Analysis is a method used in lieu of, or in addition to, testing.

4.2.2 Inspection

Inspection (I) is the physical evaluation to ensure that the requirement(s) has been incorporated or met. Inspection shall be used as the method on the product to satisfy such requirements as construction features, workmanship, dimensions, and physical conditions identified on the engineering documentation (e.g., drawings, Engineering Parts List).

CHECK THE MASTER LIST VERIFY THAT THIS IS THE CORRECT VERSION BEFORE USE at
<https://repository.msfc.nasa.gov/docs/multiprogram/MSFC-SPEC-521>

MSFC Technical Standard ES42		
Title: Electromagnetic Compatibility Requirements for Equipment and Subsystems	Document No.: MSFC-SPEC-521	Revision: C
	Effective Date: July 1, 2013	Page 40 of 75

4.2.3 Demonstration

Demonstration (D) is the “acting out” to ensure the requirement(s) has been incorporated or met. Demonstration shall be used as the method on the product to satisfy such requirements as accessibility, replace-ability, and human factors.

4.2.4 Test

Test (T) (e.g., functional, environmental) is the actual operation to ensure that the performance is in accordance with the requirement(s).

4.2.5 Validation of Records

Validation of records (VR) is the use of vendor-furnished/supplied manufacturing or processing records to ensure the requirement(s) has been incorporated or met. Validation of records shall be used as the method to satisfy incorporation of requirements for such items as commercial off-the-shelf products and products purchased to standards.

4.2.6 Similarity

Similarity (S) is the process of assessing prior data, configuration, processes, or applications and concluding that the item under assessment is similar or identical to another item that has previously been verified to equivalent or more stringent specifications or validated to an equivalent use or function. Similarity shall only be used when each of the following criteria is met:

1. Engineering evaluation(s) reveal(s) that design configurations between the item under assessment and the similar item would produce the same results if the verification/validation activity were performed on the item under assessment.
2. The similar item was designed for and verified/validated to equal or higher environmental (e.g., thermal, stress) levels than those required for the item under assessment.
3. The item under assessment was built by the same manufacturer using the same manufacturing processes and the same quality control procedures as the similar item.
4. Similarity assessment shall undergo an independent evaluation by a technically qualified person or group other than the person(s) performing the assessment.

Similarity shall not be used when either of the following conditions exists:

- a. The similar item used in the assessment was itself verified/validated using similarity as the method.

MSFC Technical Standard ES42		
Title: Electromagnetic Compatibility Requirements for Equipment and Subsystems	Document No.: MSFC-SPEC-521	Revision: C
	Effective Date: July 1, 2013	Page 41 of 75

b. Items whose criticality is 1 or 1R (i.e., items whose failure or malfunction could result in loss of vehicle, life, or serious injury).

MSFC Technical Standard ES42		
Title: Electromagnetic Compatibility Requirements for Equipment and Subsystems	Document No.: MSFC-SPEC-521	Revision: C
	Effective Date: July 1, 2013	Page 42 of 75

Table II. Verification Methods

Requirement	Title	Method						Verification Method Comments	Verification Success Criteria
		A	I	D	T	VR	S		
3.1	System Compatibility							NA	
3.1.1	Functional Compatibility								
3.1.2	Safety Critical Circuits	X			X			Test and/or analysis	Verification is successful when test and/or analysis results show that the critical circuit's threshold of susceptibility is 6dB or more (16.5 dB for pyrotechnic circuits) above the equipment's intended operational electromagnetic environment
3.2	Design Requirements							NA	
3.2.1	Primary Power							NA	
3.2.1.1	System							NA	
3.2.1.2	Equipment/LRU Power Grounding							NA	
3.2.1.2.1	Interface 1		X					Inspection of engineering documentation	Verification is successful when inspection shows the voltage source is referenced to ground and the grounding circuit is fully enclosed within the equipment chassis

MSFC Technical Standard ES42		
Title: Electromagnetic Compatibility Requirements for Equipment and Subsystems	Document No.: MSFC-SPEC-521	Revision: C
	Effective Date: July 1, 2013	Page 43 of 75

Requirement	Title	Method						Verification Method Comments	Verification Success Criteria
		A	I	D	T	VR	S		
3.2.1.2.2	Interface 2		X					Inspection of engineering documentation Inspection of workmanship test results Analysis may be required to show isolation in all operational modes	Verification is successful when inspection shows equipment maintains a 1 MΩ isolation between primary power lines and chassis and between primary and secondary power lines
3.2.1.2.3	Secondary Power		X					Inspection of engineering documentation Inspection of workmanship test results	Verification is successful when inspection shows equipment maintains a 1 MΩ isolation between primary and secondary power lines
3.2.1.3	Equipment/LRU Signals Grounding Considerations							NA	
3.2.1.3.1	Signal Grounding		X					Inspection of engineering documentation Inspection of workmanship test results	Verification is successful when inspection shows equipment signal returns maintains a 1 MΩ isolation except at the source end
3.2.1.3.2	Signal Returns		X					Inspection of engineering documentation Inspection of workmanship test results	Verification is successful when inspection shows equipment signal, command, control, and power circuits routed externally employ separate returns and returns maintains a 1 MΩ isolation from harness shields
3.2.1.3.3	Balanced Differential Circuit Isolation		X					Inspection of engineering documentation Inspection of workmanship test	Verification is successful when inspection shows balanced differential circuits routed

CHECK THE MASTER LIST VERIFY THAT THIS IS THE CORRECT VERSION BEFORE USE at
<https://repository.msfc.nasa.gov/docs/multiprogram/MSFC-SPEC-521>

MSFC Technical Standard ES42		
Title: Electromagnetic Compatibility Requirements for Equipment and Subsystems	Document No.: MSFC-SPEC-521	Revision: C
	Effective Date: July 1, 2013	Page 44 of 75

Requirement	Title	Method						Verification Method Comments	Verification Success Criteria
		A	I	D	T	VR	S		
								results	external to equipment has 6 kΩ or greater isolation to chassis
3.2.1.3.4	Coaxial Shields		X					Inspection of engineering documentation Inspection of workmanship test results	Verification is successful when inspection shows all frequency components of signals carried on coax is greater than 1 MHz and coax interconnecting equipment using different power sources does not violated SPG
3.2.2	Enclosure Shielding							NA	
3.2.3	Electrical Bonding		X					Inspection of engineering documentation Inspection of workmanship test results	Verification is successful when inspection shows he equipment has the necessary provisions for electrical bonding and the provisions, including the bond straps comply with the requirements for cleanliness, surface finish, and dimensions.
3.2.4	Circuit Classification		X					Inspection of engineering documentation Inspection of workmanship test results	Verification is successful when inspection shows that wiring of different EMC classifications are separated by mechanical shielding (conduit, cable trays, etc.) or by a minimum of 5 cm

MSFC Technical Standard ES42		
Title: Electromagnetic Compatibility Requirements for Equipment and Subsystems	Document No.: MSFC-SPEC-521	Revision: C
	Effective Date: July 1, 2013	Page 45 of 75

Requirement	Title	Method						Verification Method Comments	Verification Success Criteria
		A	I	D	T	VR	S		
3.2.5	Wire Twisting		X					Inspection of engineering documentation Inspection of workmanship test results	Verification is successful when inspection shows returns are twisted with the high side, signal and power circuits twisted with their respective return and multiple circuits using a common return are twisted as a group
3.2.6	Wire Shielding		X					Inspection of engineering documentation Inspection of workmanship test results	Verification is successful when inspection shows cable shields cover the twisted pair or group and shields do not intentionally carry current (except coax). Verification is successful when inspection also shows cable connectors used to terminate cable shields are installed to provide a low impedance path to case with the dc resistance not to exceed 2.5 mΩ.
3.3	Subsystem and Equipment Emission and Susceptibility Requirements							NA	
3.3.1	Equipment Produced Emission							NA	
3.3.1.1	Conducted Emissions (CE)							NA	
3.3.1.1.1	DC Power Bus Ripple (CE101)							See MIL-STD-461F and appendix B for test setup and procedure	

CHECK THE MASTER LIST VERIFY THAT THIS IS THE CORRECT VERSION BEFORE USE at
<https://repository.msfc.nasa.gov/docs/multiprogram/MSFC-SPEC-521>

MSFC Technical Standard ES42		
Title: Electromagnetic Compatibility Requirements for Equipment and Subsystems	Document No.: MSFC-SPEC-521	Revision: C
	Effective Date: July 1, 2013	Page 46 of 75

Requirement	Title	Method						Verification Method Comments	Verification Success Criteria
		A	I	D	T	VR	S		
3.3.1.1.1.1	CE101 Limits				X				Conducted emissions on power leads shall not exceed the applicable limits
3.3.1.1.2	DC Power Bus RF (CE102)							See MIL-STD-461F and appendix B for test setup and procedure	
3.3.1.1.2.1	CE102 Limits				X				Conducted emissions on power leads shall not exceed the applicable limits
3.3.1.1.3	Conducted Emissions, antenna terminal, 10 kHz to 40 GHz (CE106)							See MIL-STD-461F and appendix B for test setup and procedure	
3.3.1.1.3.1	CE106 Limits				X				Conducted emissions at antenna terminals shall not exceed the applicable limits
3.3.1.1.4	Conducted Emissions, time domain, DC power levels, Transient and Steady State (CE107)							See Appendix B of this document for test setup and procedure	
3.3.1.1.4.1	CE107 Limits				X				Conducted turn-on transient emissions on power leads shall not exceed the applicable limits
3.3.1.1.5	Conducted Emissions, Bulk Cable Emissions (BCE), 150 kHz to 200 MHz (CE108)							See Appendix B of this document for test setup and procedure	
3.3.1.1.5.1	CE108 Limits				X				Conducted common mode emissions on interconnecting cables shall not

CHECK THE MASTER LIST VERIFY THAT THIS IS THE CORRECT VERSION BEFORE USE at
<https://repository.msfc.nasa.gov/docs/multiprogram/MSFC-SPEC-521>

MSFC Technical Standard ES42		
Title: Electromagnetic Compatibility Requirements for Equipment and Subsystems	Document No.: MSFC-SPEC-521	Revision: C
	Effective Date: July 1, 2013	Page 47 of 75

Requirement	Title	Method						Verification Method Comments	Verification Success Criteria
		A	I	D	T	VR	S		
									exceed the applicable limits
3.3.1.2	Radiated Emissions (RE)							NA	
3.3.1.2.1	Radiated Emissions, magnetic field, 30 Hz to 100 kHz (RE101)							See MIL-STD-461F and appendix B for test setup and procedure	
3.3.1.2.1.1	RE101 Limits								
3.3.1.2.2	Radiated Emissions, electric field, 100 MHz to 18 GHz (RE102)							See MIL-STD-461F and appendix B for test setup and procedure	
3.3.1.2.2.1	RE102 Limits				X				Electric field emissions shall not be radiated in excess of those shown in the applicable Figures
3.3.1.2.3	Radiated Emissions, antenna spurious and harmonic outputs, 10 kHz to 40 GHz (RE103)							See MIL-STD-461F and appendix B for test setup and procedure	
3.3.1.2.3.1	RE103 Limits				X				Harmonics except the second and third, and all other spurious emissions shall be at least 80 dB down from the level at the fundamental.
3.3.2	Equipment Susceptibility							NA	
3.3.2.1	Conducted Susceptibility (CS)							NA	
3.3.2.1.1	Conducted Susceptibility, power leads, 30							See MIL-STD-461F and appendix B for test setup and	

CHECK THE MASTER LIST VERIFY THAT THIS IS THE CORRECT VERSION BEFORE USE at
<https://repository.msfc.nasa.gov/docs/multiprogram/MSFC-SPEC-521>

MSFC Technical Standard ES42		
Title: Electromagnetic Compatibility Requirements for Equipment and Subsystems	Document No.: MSFC-SPEC-521	Revision: C
	Effective Date: July 1, 2013	Page 48 of 75

Requirement	Title	Method						Verification Method Comments	Verification Success Criteria
		A	I	D	T	VR	S		
	Hz to 150 kHz (CS101)							procedure	
3.3.2.1.1.1	CS101 Limits				X				The EUT will not exhibit any malfunction, degradation of performance, or deviation from specified indications when subject to the CS 101 test limits
3.3.2.1.2	Conducted Susceptibility, negative transients, power leads (CS106)							See Appendix B of this document for test setup and procedure	
3.3.2.1.2.1	CS106 Limits				X				The EUT will not exhibit any malfunction, degradation of performance, or deviation from specified indications when subject to the CS 106 test limits
3.3.2.1.3	Conducted Susceptibility, structure current, 60 Hz to 100 kHz (CS109)							See MIL-STD-461F and appendix B for test setup and procedure	
3.3.2.1.3.1	CS109 Limits				X				The EUT will not exhibit any malfunction, degradation of performance, or deviation from specified indications when subject to the CS 109 test limits
3.3.2.1.4	Conducted Susceptibility, bulk cable injection, 10 kHz to 200							See MIL-STD-461F and appendix B for test setup and procedure	

CHECK THE MASTER LIST VERIFY THAT THIS IS THE CORRECT VERSION BEFORE USE at
<https://repository.msfc.nasa.gov/docs/multiprogram/MSFC-SPEC-521>

MSFC Technical Standard ES42		
Title: Electromagnetic Compatibility Requirements for Equipment and Subsystems	Document No.: MSFC-SPEC-521	Revision: C
	Effective Date: July 1, 2013	Page 49 of 75

Requirement	Title	Method						Verification Method Comments	Verification Success Criteria
		A	I	D	T	VR	S		
	MHz (CS114)								
3.3.2.1.4.1	CS114 Limits				X				The EUT will not exhibit any malfunction, degradation of performance, or deviation from specified indications when subject to the CS 114 test limits
3.3.2.1.5	Conducted Susceptibility, damped sinusoid transients, cables and power leads, 10 kHz to 100 MHz (CS116) [satellite payloads exempted]							See MIL-STD-461F and appendix B for test setup and procedure	
3.3.2.1.5.1	CS116 Limits				X				The EUT will not exhibit any malfunction, degradation of performance, or deviation from specified indications when subject to the CS 116 test limits
3.3.2.2	Radiated Susceptibility (RS)								
3.3.2.2.1	Radiated Susceptibility, magnetic field, 30 Hz to 100 kHz (RS101)							See MIL-STD-461F and appendix B for test setup and procedure	
3.3.2.2.1.1	RS101 Limits				X				The EUT will not exhibit any malfunction, degradation of performance, or deviation from

CHECK THE MASTER LIST VERIFY THAT THIS IS THE CORRECT VERSION BEFORE USE at
<https://repository.msfc.nasa.gov/docs/multiprogram/MSFC-SPEC-521>

MSFC Technical Standard ES42		
Title: Electromagnetic Compatibility Requirements for Equipment and Subsystems	Document No.: MSFC-SPEC-521	Revision: C
	Effective Date: July 1, 2013	Page 50 of 75

Requirement	Title	Method						Verification Method Comments	Verification Success Criteria
		A	I	D	T	VR	S		
									specified indications when subject to the RS 101 test limits
3.3.2.2.2	Radiated Susceptibility, electric field, 2 MHz to 40 GHz (RS103)							See MIL-STD-461F and appendix B for test setup and procedure	
3.3.2.2.2.1	RS103 Limits				X				The EUT will not exhibit any malfunction, degradation of performance, or deviation from specified indications when subject to the RS 103 test limits

5.0 PACKAGING

Not Applicable

6.0 NOTES

Not Applicable

MSFC Technical Standard ES42		
Title: Electromagnetic Compatibility Requirements for Equipment and Subsystems	Document No.: MSFC-SPEC-521	Revision: C
	Effective Date: July 1, 2013	Page 51 of 75

APPENDIX A ACRONYMS AND ABBREVIATIONS

A	Ampere, Analysis
AC	Alternating Current
BCE	Bulk Cable Emission
C	Capacitance, capacitor
CE	Conducted Emission
CLV	Crew Launch Vehicle
cm	Centimeter(s)
CS	Conducted Susceptibility
D	Demonstration
dB	Decibel
dBm	Decibels to one Milliwatt
dB μ V	Decibels to one Microvolts
dBpT	Decibels to one Picotesla
DC	Direct Current
DE	Design and Development Engineering
DoD	Department of Defense
E3	Electromagnetic Environmental Effects
EIA	Electronics Industries Association
EMC	Electromagnetic Compatibility
EMI	Electromagnetic Interference
EMP	Electromagnetic Pulse
EPS	Electrical Power System
EUT	Equipment Under Test
GHz	gigahertz
Hz	Hertz
I	Inspection
ICD	Interface Control Document
IEEE	Institute of Electronics and Electrical Engineers
ISS	International Space Station
JSC	Johnson Space Center
k Ω	Kilohm

CHECK THE MASTER LIST VERIFY THAT THIS IS THE CORRECT VERSION BEFORE USE at
<https://repository.msfc.nasa.gov/docs/multiprogram/MSFC-SPEC-521>

MSFC Technical Standard ES42		
Title: Electromagnetic Compatibility Requirements for Equipment and Subsystems	Document No.: MSFC-SPEC-521	Revision: C
	Effective Date: July 1, 2013	Page 52 of 75

kHz	Kilohertz
L	Inductance
LISN	Line Impedance Stabilization Network
LNA	Low-noise amplifiers
LRU	Line Replaceable Unit
m	Meter(s)
m ²	Square Meters
MHz	Megahertz
MIL-HDBK	Military Handbook
MIL-STD	Military Standard
min	Minute
MPR	Marshall Procedural Requirements
MSFC	Marshall Space Flight Center
MSL	Material Science Laboratory
MΩ	Megaohms
N/A	Not Applicable
NA	Not Applicable
NASA	National Aeronautics and Space Administration
NDI	Non-Developmental Item
NPR	NASA Procedural Requirements
ns	Nanosecond(s)
NSTS	National Space Transportation System
RC	Resistor/Capacitor
RE	Radiated Emission
RF	Radio Frequency
RMS	Root Mean Square
RS	Radiated Susceptibility
RTCA	Radio Technical Commission for Aeronautics
s	Second
S	Similarity
SI	Le System International d'Unites
SPG	Single Point Ground
SPEC	Specification

CHECK THE MASTER LIST VERIFY THAT THIS IS THE CORRECT VERSION BEFORE USE at
<https://repository.msfc.nasa.gov/docs/multiprogram/MSFC-SPEC-521>

MSFC Technical Standard ES42		
Title: Electromagnetic Compatibility Requirements for Equipment and Subsystems	Document No.: MSFC-SPEC-521	Revision: C
	Effective Date: July 1, 2013	Page 53 of 75

STD	Standard
T	Test
μF	Microfarad
UL	Underwriters Laboratories
V	Volt
V/m	Volts per Meter
VAC	Volts Alternating Current
VDC	Volts Direct Current
VR	Validation of Records
W	Watts
Ω	Ohm

MSFC Technical Standard ES42		
Title: Electromagnetic Compatibility Requirements for Equipment and Subsystems	Document No.: MSFC-SPEC-521	Revision: C
	Effective Date: July 1, 2013	Page 54 of 75

APPENDIX B TEST METHODOLOGIES

B.1 Test Configuration Setups

B.2 CE107, Conducted Emissions, Time Domain, DC Power Levels, Transient and Steady State

B.2.1 CE107 Test Procedures

B.2.2 CE108, Conducted Emissions, Bulk Cable Emission (BCE), 150 kHz to 200 MHz

B.2.2.1 CE108 Test Procedures

B.2.3 CS106, Power Line Switching Transients

B.2.3.1 CS106 Test Procedures

MSFC Technical Standard ES42		
Title: Electromagnetic Compatibility Requirements for Equipment and Subsystems	Document No.: MSFC-SPEC-521	Revision: C
	Effective Date: July 1, 2013	Page 55 of 75

B.1 Test Configuration Setups

B.1.1 Ground Plane

The EUT shall be installed on a ground plane that simulates the actual installation. If the actual installation is unknown or multiple installations are expected, then a metallic ground plane shall be used. Unless otherwise specified below, ground planes shall be 2.25 m² or larger in area with the smaller side no less than 76 cm. When a ground plane is not present in the EUT installation, the EUT shall be placed on a nonconductive table.

B.1.1.1 Metallic Ground Plane

When the EUT is installed on a metallic ground plane, the ground plane shall have a surface resistance no greater than 0.1 milliohms per square. The DC resistance between metallic ground planes and the shielded enclosure shall be 2.5 milliohms or less. The metallic ground planes shown in Figure 21 through Figure 23 shall be electrically bonded to the floor or wall of the basic shielded room structure at least once every 1 m. The metallic bond straps shall be solid and maintain a five-to-one ratio or less in length to width. Metallic ground planes used outside a shielded enclosure shall extend at least 1.5 m beyond the test setup boundary in each direction.

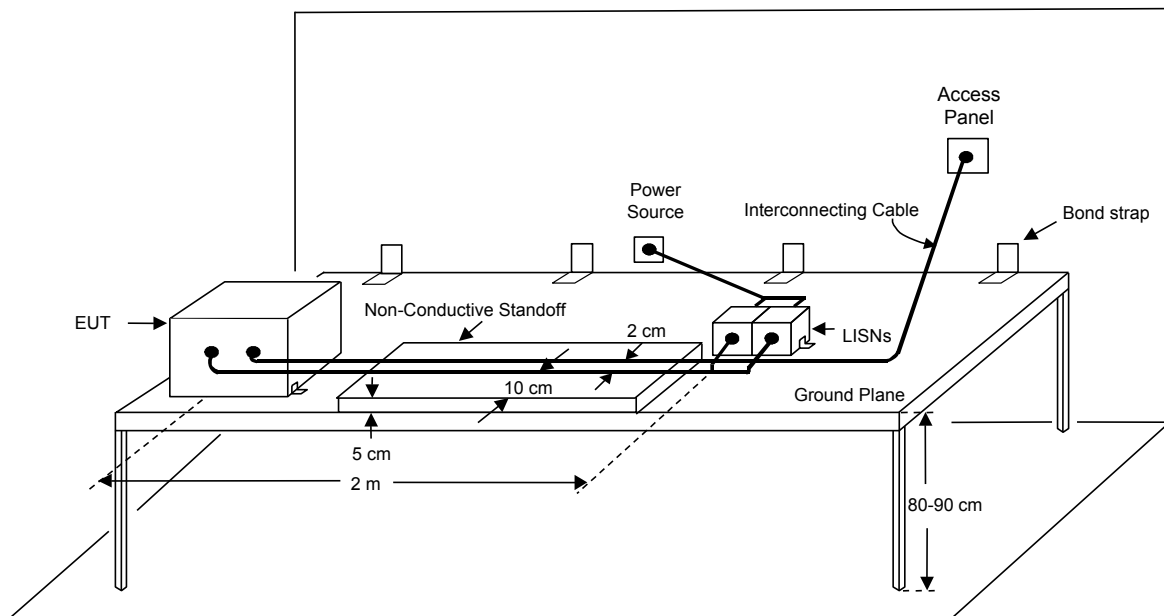

Figure 21. General test setup with a conductive ground plane

MSFC Technical Standard ES42		
Title: Electromagnetic Compatibility Requirements for Equipment and Subsystems	Document No.: MSFC-SPEC-521	Revision: C
	Effective Date: July 1, 2013	Page 56 of 75

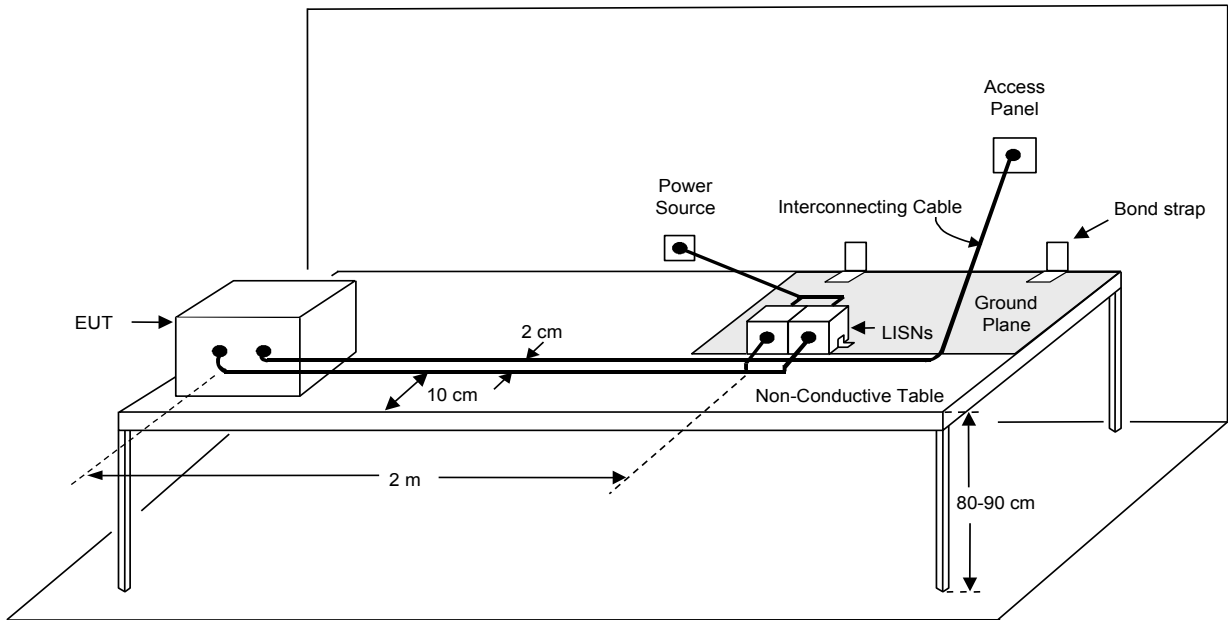

Figure 22. Test setup for nonconductive surface mounted EUT

MSFC Technical Standard ES42		
Title: Electromagnetic Compatibility Requirements for Equipment and Subsystems	Document No.: MSFC-SPEC-521	Revision: C
	Effective Date: July 1, 2013	Page 57 of 75

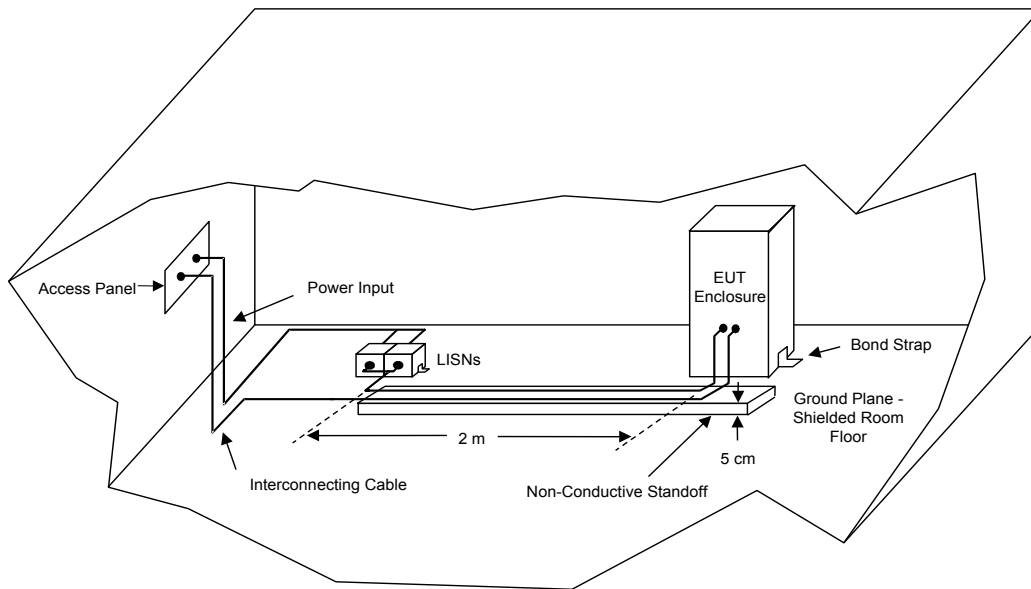

Figure 23. Test setup for freestanding EUT in shielded enclosure

B.1.1.2 Composite Ground Plane

When the EUT is installed on a conductive composite ground plane, the surface resistivity of the typical installation shall be used. Composite ground planes shall be electrically bonded to the enclosure with means suitable to the material.

B.1.1.3 General Test Requirements

Testing will comply with the general requirements of MIL-STD-461F, section 4.3, except the LISNs used will be as listed below.

B.1.1.4 Test Methodology

Test methods for showing compliance with the requirements of section 3.3 will be those of MIL-STD-461F. Requirements CE107, CE108, and CS106 (as specified herein) are not in MIL-STD-461F. The test procedures for those requirements are listed below.

B.1.1.5 LISN

The LISNs used for EUT testing will be the 5 microhenry LISNs defined in RTCA DO-160G, Sections 20 and 21 for all tests including CE107 and CS106. Ten-microfarad feed-through capacitors may be connected to the facility power input of the LISNs to minimize self-resonances of the LISNs. During CE107 and CS106 tests, additional line-to-line capacitance may be added at power input of the LISNs to minimize power source voltage drop.

MSFC Technical Standard ES42		
Title: Electromagnetic Compatibility Requirements for Equipment and Subsystems	Document No.: MSFC-SPEC-521	Revision: C
	Effective Date: July 1, 2013	Page 58 of 75

B.2 CE107, Conducted Emissions, Time Domain, DC Power Levels, Transient and Steady State

B.2.1 CE107 Test Procedures

B.2.1.1 Purpose

This test procedure is used to verify, in the time domain, that the load-induced effect on power bus voltage caused by cycling the EUT on, as well as through any and all of its various modes of operation which might reasonably be expected to affect line voltage significantly, do not exceed the limits set forth in the governing power quality specification.

B.2.1.2 Test Equipment

The test equipment shall be as follows:

- a. LISN.
- b. Capacitor (C) ($\geq 1,000 \mu\text{F}$).
- c. Data recording device.
- d. Solid-state switch (to energize/de-energize EUT). [Switch-on resistance must be low enough and turn-on time fast enough to not interfere with the turn-on transient.]
- e. Digital storage oscilloscope (10-MHz, single-event bandwidth).
- f. Resistive load (R_{load}) for verifying test setup and measurement accuracy.

B.2.1.3 Setup

The test setup shall be as follows:

- a. Maintain a basic test setup for the EUT as shown and described in Figure 21 through Figure 23.
- b. Calibration. Configure the test setup for the measurement system check as shown in Figure 24. The resistor " R_{load} " in Figure 24 shall have a value that draws the same steady-state current as the EUT.
- c. EUT testing; Configure the test setup for compliance testing of the EUT as shown in Figure 25.

MSFC Technical Standard ES42		
Title: Electromagnetic Compatibility Requirements for Equipment and Subsystems	Document No.: MSFC-SPEC-521	Revision: C
	Effective Date: July 1, 2013	Page 59 of 75

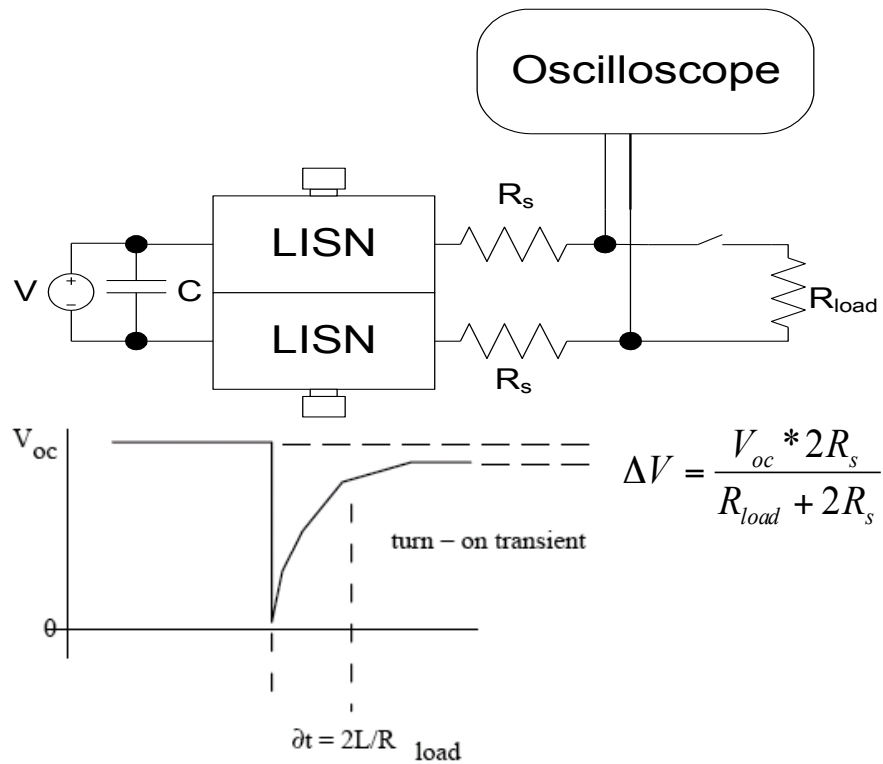

Figure 24. CE107 Measurement system check setup

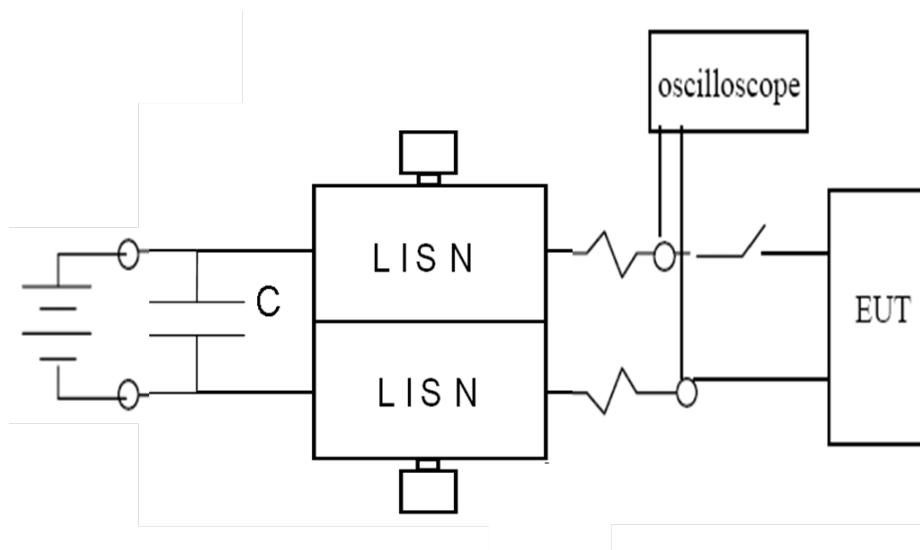

Figure 25. CE107 Measurement setup

MSFC Technical Standard ES42		
Title: Electromagnetic Compatibility Requirements for Equipment and Subsystems	Document No.: MSFC-SPEC-521	Revision: C
	Effective Date: July 1, 2013	Page 60 of 75

B.2.1.4 Procedure

The test procedures shall be as follows:

a. Calibration. Perform the measurement system check using the measurement system check setup of Figure 24.

- (1) Turn on the measurement equipment and allow sufficient time for stabilization.
- (2) For turn-on transient: Set time per division to bracket expected L/R time constant. Use 5 or 10 V/division sensitivity. Set up trigger to look for a negative-going transient. Set threshold to a few volts below Open Circuit Voltage (Voc). Set up a single trace acquisition (acquire and hold).
- (3) Use oscilloscope to verify that transient waveforms are as shown in Figure 24.

b. EUT testing. Perform transient measurement using the setup of Figure 25.

- (1) Apply power to LISN. Wait at least 1 sec after EUT has been de-energized before measuring a turn-on transient event.
- (2) Configure oscilloscope for turn-on transient measurement per Figure 25 except that transient waveform will typically be longer than that calibrated, and time per division will have to be empirically determined.
- (3) Measure and record turn-on transient as switch is closed. Configure oscilloscope for steady-state measurement per Figure 25.

B.2.1.5 Data Presentation

Data presentation shall be as follows:

- a. Oscillograph of transient waveform, including all axis and unit labels necessary for proper interpretation.
- b. Display the applicable limit on each plot.
- c. Provide plots for both the measurement system check and measurement portions of the procedure.

B.2.2 CE108, Conducted Emissions, Bulk Cable Emission (BCE), 150 kHz to 200 MHz

B.2.2.1 CE108 Test Procedures

MSFC Technical Standard ES42		
Title: Electromagnetic Compatibility Requirements for Equipment and Subsystems	Document No.: MSFC-SPEC-521	Revision: C
	Effective Date: July 1, 2013	Page 61 of 75

B.2.2.1.1 Purpose

This test procedure is used to verify that electromagnetic emissions from the EUT do not exceed the specified requirements for EUT interconnecting cables.

B.2.2.1.2 Test Equipment

The test equipment shall be as follows:

- a. Measurement receivers.
- b. Data recording device.
- c. Absorbing clamp (per CISPR 16, Specification for radio disturbance and immunity measuring apparatus and methods).
- d. Signal generators.
- e. LISNs.

Note: Absorbing clamp must be calibrated as a current probe, not per CISPR 16.

B.2.2.1.3 Setup

The test setup shall be as follows:

- a. Maintain a basic test setup for the EUT as shown and described in Figure 21 through Figure 23.
- b. Calibration. Configure the test equipment in accordance with Figure 26.
- c. EUT testing. Configure the test setup for testing of the EUT as shown in Figure 27.

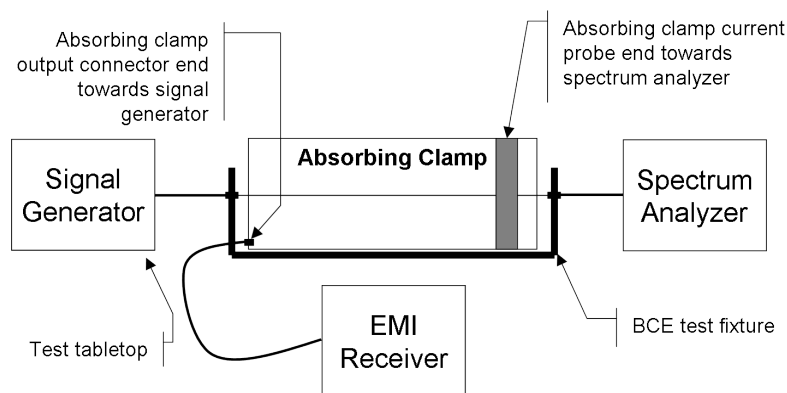

Figure 26. CE108 Calibration diagram

MSFC Technical Standard ES42		
Title: Electromagnetic Compatibility Requirements for Equipment and Subsystems	Document No.: MSFC-SPEC-521	Revision: C
	Effective Date: July 1, 2013	Page 62 of 75

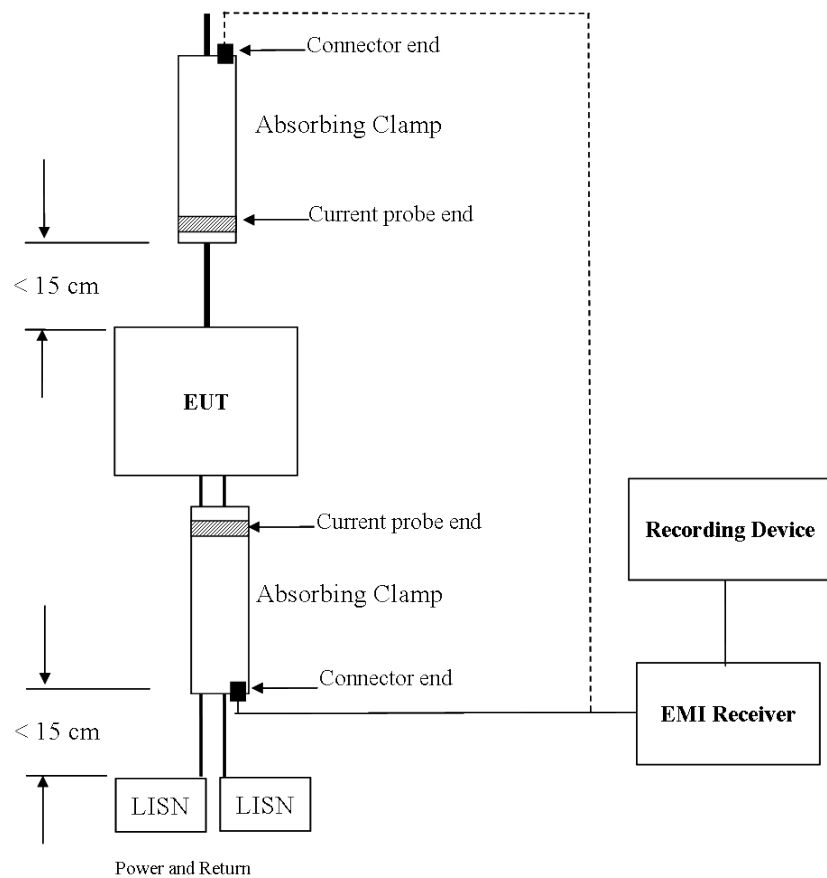

Figure 27. CE108 Bulk cable emission test setup

B.2.2.1.4 Procedures

The test procedures shall be as follows:

- a. Turn on the measurement equipment and allow sufficient time for stabilization.
- b. Calibration.
 - (1) Set signal generator to a potential that will yield a current flow at 6 dB below the limit at 150 kHz, 10 MHz, and 200 MHz.
 - (2) Scan the measurement receiver in the same manner as a normal data scan. Verify that the data-recording device indicates a level within ± 3 dB of the injected signal level.
 - (3) If readings are obtained which deviate by more than ± 3 dB, locate the source of the error and correct the deficiency prior to proceeding with the testing.

MSFC Technical Standard ES42		
Title: Electromagnetic Compatibility Requirements for Equipment and Subsystems	Document No.: MSFC-SPEC-521	Revision: C
	Effective Date: July 1, 2013	Page 63 of 75

c. EUT testing.

(1) Turn on the EUT and allow sufficient time for stabilization.

(2) Using the setup of Figure 27, measure common mode emissions on all EUT attached cables (both power and signal).

(3) While maintaining at least the required signal level, scan through the required frequency range at a rate no greater than specified in MIL-STD-461F, Table II.

Note: Both power conductors are tested together to ensure that only common-mode power-line conducted emissions (CEs) are measured.

(a) Scan the measurement receiver for each applicable frequency range, using the bandwidths and minimum measurement times in MIL-STD-461F, Table II.

(b) Repeat the measurement for all applicable interconnecting cables and take measurements for each frequency range.

B.2.2.1.5 Data Presentation

Data presentation shall be as follows:

a. Continuously and automatically plot amplitude versus frequency profiles. Manually gathered data is not acceptable except for plot verification.

b. Display the applicable limit on each plot.

c. Provide a minimum frequency resolution of 1% or twice the measurement receiver bandwidth, whichever is less stringent, and a minimum amplitude resolution of 1 dB for each plot.

d. Provide plots for both the measurement and system check portions of the procedure.

B.2.3 CS106, Power Line Switching Transients

B.2.3.1 CS106 Test Procedures

B.2.3.1.1 Purpose

This test procedure is used to verify the ability of the EUT to withstand power line load-induced switching transients.

B.2.3.1.2 Test Equipment

The test equipment shall be as follows:

CHECK THE MASTER LIST VERIFY THAT THIS IS THE CORRECT VERSION BEFORE USE at
<https://repository.msfc.nasa.gov/docs/multiprogram/MSFC-SPEC-521>

MSFC Technical Standard ES42		
Title: Electromagnetic Compatibility Requirements for Equipment and Subsystems	Document No.: MSFC-SPEC-521	Revision: C
	Effective Date: July 1, 2013	Page 64 of 75

- a. Switching transient generator.
- b. Oscilloscope, $\geq 1\text{-M}\Omega$ input impedance.
- c. LISNs.
- d. 50- μf capacitor rated above 28 working volts DC (nominal capacitor value) for 28 Vdc applications or 200-uf capacitor rated above 120 working volts DC (nominal capacitor value).
- e. 4- Ω , 1-W resistor (nominal resistance value) for 28 Vdc applications or 10- Ω , 1-W resistor (nominal resistance value) for 120 Vdc applications.

B.2.3.1.3 Setup

The test setup shall be as follows:

- a. Maintain a basic test setup for the EUT as shown and described in Figure 21 through Figure 23.
- b. Calibration. Configure the test equipment in accordance with Figure 28 for calibrating the switching transient. Set transient generator for “turn-on” (negative polarity) transient. Set pulse rate to nominal 1-Hz rate. Perform a differential oscilloscope measurement with the oscilloscope channels set to 1-M Ω input impedance.
- c. EUT testing. Configure per Figure 28 calibration, except that the EUT is now connected to power.

MSFC Technical Standard ES42		
Title: Electromagnetic Compatibility Requirements for Equipment and Subsystems	Document No.: MSFC-SPEC-521	Revision: C
	Effective Date: July 1, 2013	Page 65 of 75

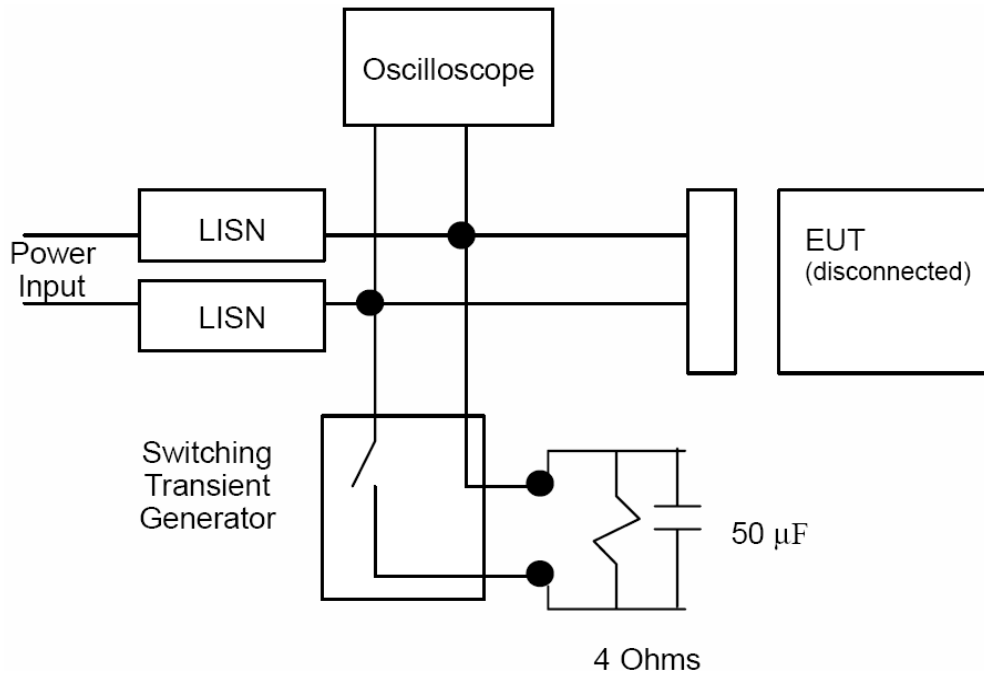

Note: This shows the calibration for the 28 Vdc test limit. For calibrating the 120 Vdc test limit, replace the 50 μ F capacitor with a 200 μ F capacitor and replace the 4 Ω with a 10 Ω resistor.

Figure 28. CS106 Calibration setup

B.2.3.1.4 Procedures

The test procedures shall be as follows:

- a. Turn on the measurement equipment (oscilloscope) and allow sufficient time for stabilization.
 - b. Calibration. Perform the following procedures using the calibration setup.
 1. Verify that transient amplitude and duration are no less than shown in Figure B2.3.1.3-1.
 2. After recording waveforms, shut off transient generator.
 - c. EUT testing.
 1. Turn on the EUT and allow sufficient time for stabilization.
 2. Susceptibility evaluation.
- (c) Initiate transient generation. Operate for 1 min in negative polarity mode. Verify proper operation of EUT. Shut down transient generator.

MSFC Technical Standard ES42		
Title: Electromagnetic Compatibility Requirements for Equipment and Subsystems	Document No.: MSFC-SPEC-521	Revision: C
	Effective Date: July 1, 2013	Page 66 of 75

(d) Whenever susceptibility is noted, determine the threshold level in accordance with Paragraph Figure B2.3.1.3-1 and verify that it is above the limit. The transient duration is to be modified by changing switched capacitor and/or resistor value. The amplitude cannot be changed. When a resistor/capacitor (RC) combination is found that yields the threshold of susceptibility, record the injected waveform as well as the waveform that combination yields in the pre-calibration setup (EUT disconnected). It is recommended to leave the 4-Ω (or 10Ω) resistor in place and swap the capacitor to values of 100 μF (120 Vdc testing only), 50 μF (120 Vdc testing only), 22 μF, 10 μF, and 5 μF.

(e) Record samples of transients injected into EUT. These waveforms may differ from those pre-calibrated.

B.2.3.1.5 Data Presentation

Data presentation shall be as follows:

- a. Oscilloscope traces for calibration transients.
- b. Oscilloscope traces for EUT-injected transients.

Provide any susceptibility thresholds and recorded waveforms thereof that were determined.

MSFC Technical Standard ES42		
Title: Electromagnetic Compatibility Requirements for Equipment and Subsystems	Document No.: MSFC-SPEC-521	Revision: C
	Effective Date: July 1, 2013	Page 67 of 75

APPENDIX C Requirements Background and guidance

C.1.0 INTRODUCTION

This appendix provides background information for each emission and susceptibility requirement in the main body of the standard. This information includes rationale for requirements and guidance in applying the requirements. This information should help users understand the intent behind the requirements and should aid the procuring activity in tailoring emission and susceptibility requirements as necessary for particular applications. This appendix is provided for guidance purposes and, as such, should not be interpreted as providing contractual requirements.

This appendix follows the same general format as the main body of the specification.

C.3.0 REQUIREMENTS

C.3.1 System Compatibility

C.3.1.1 Functional Compatibility

This document provides a set of requirements for equipment and subsystems. The equipment must be self-compatible and compatible with other platform or carrier subsystems and the operational environment.

Equipment must comply with the emissions requirements contained in this specification and any non-compliance must be evaluated against the other equipment and subsystems on the platform. The equipment must also comply with susceptibility requirements contained herein and non-compliances must be evaluated against platform or carrier environment, including that generated by the platform or carrier and its operational environment.

While compliance with the requirements of this specification does not guarantee EMC, it does provide risk mitigation against interference and incompatibilities.

C.3.1.2 Safety Critical Circuits

In order to prevent critical or catastrophic hazards, equipment containing critical circuits must demonstrate that circuit thresholds of susceptibility are 6 dB (16.5 dB for pyrotechnic circuits) or more above the expected environment.

The use of margins simply recognizes that there is variability in manufacturing and that requirement verification has uncertainties.

MSFC Technical Standard ES42		
Title: Electromagnetic Compatibility Requirements for Equipment and Subsystems	Document No.: MSFC-SPEC-521	Revision: C
	Effective Date: July 1, 2013	Page 68 of 75

Margins may be demonstrated in a number of ways. Simply doubling the susceptibility test levels contained in this specification is not recommended. Doing so may lead to over-testing or, in some cases, test failure and damage. During verification planning, it is recommended the E3 subject matter experts be brought into the planning process in order to help identify the most expeditious method of margin demonstration.

C.3.2 Design Requirements

C.3.2.1 Primary Power

Typically, primary power is vehicle or platform generated power that is distributed to the various loads. Secondary power may be distributed to other loads, but secondary power distribution is usually, but not always limited in scope. For example, the Space Shuttle Orbiter provided 28V primary power, sourced by the fuel cells, but also provided a secondary, inverter generated AC power for some loads. On the International Space Station, however, primary power is the 160V dc power, generated by the solar arrays. The 120 Vdc secondary power is widely distributed.

Interface 1 is defined as the distribution point and includes the common bus and source. Using this definition, CE101 requirements were defined to allow compliance with the power quality requirements of SAE AS5698, Space Power Standard. CS101 requirements were developed to ensure that the equipment would continue to operate when subjected to the ripple voltage specified in SAE AS5698 at its input.

C.3.2.1.1 System

The grounding requirements contained in this specification assume that the equipment or subsystem will be powered by a source that is referenced to vehicle or platform structure. Therefore, it is important to maintain isolation at the loads to prevent currents from returning through structure. NASA Reference Publication 1368 Marshall Space Flight Center Electromagnetic Compatibility Design and Interference Control (MEDIC) Handbook, has more information concerning electrical grounding and a distributed single point ground concept.

C.3.2.1.2 Equipment/LRU Power Grounding

C.3.2.1.2.1 Interface 1

Equipment that provides a voltage source should reference the source to ground to allow for electrical fault clearing and enhance operability and safety. Equipment ground references should not be brought outside the equipment chassis, but should be connected as close to the source as possible to prevent noise currents and voltages from creating common mode voltages in the power circuit.

C.3.2.1.2.2 Interface 2

MSFC Technical Standard ES42		
Title: Electromagnetic Compatibility Requirements for Equipment and Subsystems	Document No.: MSFC-SPEC-521	Revision: C
	Effective Date: July 1, 2013	Page 69 of 75

DC Power consumers/converters/conditioners/distributors/etc. connected to primary power must maintain at least 1 MΩ dc isolation between both the high and return lines and chassis to prevent SPG violation and the isolation should be maintained during all operational modes to prevent sneak circuits.

Isolation between primary and secondary lines is required to prevent violation of SPG in circuitry utilizing secondary power.

C.3.2.1.2.3 Secondary Power

Isolation between primary and secondary is best achieved through the use of transformers. If secondary power is not further referenced to structure (i.e. floating output), then no SPG violation occurs and the intent of the requirement is met. However, circuitry receiving secondary power should be analyzed to ensure that no intentional or unintentional (sneak circuit) ground reference is present.

C.3.2.1.3 Equipment/LRU Signals Grounding Considerations

C.3.2.1.3.1 Signal Grounding

This requirement applies only to signals that are routed outside of the equipment to other equipment or subsystems.

C.3.2.1.3.2 Signal Returns

This requirement applies only to signals that are routed outside of the equipment to other equipment or subsystems. The use of separate returns minimizes common impedance coupling, cross talk, and allows for twisting to minimize coupling area.

C.3.2.1.3.3 Balanced Differential Circuit Isolation

Balanced differential circuits provide a high degree of common mode isolation. However, commercially available digital driver and receiver integrated circuits may have a DC resistance as low as 6 kΩ between the input or output pins and the ground pin.

C.3.2.1.3.4 Coaxial Shields

Coax is frequently used to carry video signals. However, video signals have components well below 1 MHz. As such, the low frequency components will not remain on the inner surface of the coax shield but will flow through all conductors in the shield. This can be a source of unintentional radiated emissions or radiated susceptibility coupling path.

MSFC Technical Standard ES42		
Title: Electromagnetic Compatibility Requirements for Equipment and Subsystems	Document No.: MSFC-SPEC-521	Revision: C
	Effective Date: July 1, 2013	Page 70 of 75

Typically, coax shields are terminated through connector backshells to equipment enclosures. Using coax as interconnects between equipment utilizing different power sources may violate SPG.

C.3.2.2 Enclosure Shielding

A metallic shielding material thick enough to support itself usually provides good electric field shielding at all frequencies. However, apertures and discontinuities degrade the shielding effectiveness of an equipment enclosure. NASA RP 1368 has more information concerning enclosure shielding.

C.3.2.3 Electrical Bonding

Equipment must have the necessary provisions so it can be electrically bonded to the vehicle or platform. The bonding requirements of this specification are in line with those of NASA-STD-4003A, Electrical Bonding for NASA Launch Vehicles, Spacecraft, Payloads, and Flight Equipment.

C.3.2.4 Circuit Classification

Power and signal cables may act as both transmitting and receiving antennas for radiated EMI and conduits for conducted EMI. Because cables are usually routed to accommodate practical routing paths and equipment location, it is almost impossible to predict and quantify the EMI environment associated with these cables. One way of controlling crosstalk from cables and wiring is to separate cables and wiring of dissimilar classes.

C.3.2.5 Wire Twisting

Wire twisting minimizes coupling loop areas, aiding the designer in meeting both radiated emissions and radiated susceptibility requirements.

C.3.2.6 Wire Shielding

Unshielded or improperly shielded cables are a primary source for radiated emissions and an entry point for the external RF environment. Shield terminations must provide low impedances paths for noise currents. NASA RP 1368 has more information concerning wire shielding.

C.3.3 Subsystem and Equipment Emission and Susceptibility Requirements

The basis for the emission and susceptibility requirements is primarily MIL-STD-461F, with three requirements finding their origins in SL-E 0002, Book 3, Volume 1, Shuttle Specification Electromagnetic Interference Characteristics Requirements for Equipment – Book 3 New or Modified Equipment.

MSFC Technical Standard ES42		
Title: Electromagnetic Compatibility Requirements for Equipment and Subsystems	Document No.: MSFC-SPEC-521	Revision: C
	Effective Date: July 1, 2013	Page 71 of 75

C.3.3.1 Equipment Produced Emission

C.3.3.1.1 Conducted Emissions (CE)

C.3.3.1.1.1 DC Power Bus Ripple (CE101)

This requirement is applicable from 30 Hz to 150 kHz for all primary power leads, including returns, which obtain power from other sources not part of the EUT. There is no requirement on output leads from power sources. Since power quality requirements of SAE 5698 or other standards are normally used to govern the characteristics of output power, this specification does not impose separate EMI requirements on output leads.

C.3.3.1.1.1.1 CE101 Limits

These limits for both 120 Vdc and 28 Vdc loads are derived from SAE AS5698 ripple voltage requirements, using the impedance of the 5 μ H LISN as the source impedance (see MIL-STD-461F, Appendix A for a discussion on the use of the 5 μ H LISN). In most cases, the platform or vehicle power bus impedance will not approach this value so the CE101 limits are moderately conservative. The limit, below 150 kHz, may be relaxed based on the current draw of the load.

C.3.3.1.1.2 DC Power Bus RF (CE102)

This requirement is applicable from 150 kHz to 10 MHz for all primary power leads, including returns, which obtain power from other sources not part of the EUT. Again, these limits do not apply to power source outputs.

C.3.3.1.1.2.1 CE102 Limits

These limits for both 120 Vdc and 28 Vdc loads are derived from SAE AS5698 ripple voltage requirements, using the impedance of the 5 μ H LISN as the source impedance (see MIL-STD-461F, Appendix A for a discussion on the use of the 5 μ H LISN).

C.3.3.1.1.3 Conducted Emissions, antenna terminal, 10 kHz to 40 GHz (CE106)

This requirement is applicable to the antenna terminals of transmitters, receivers, and amplifiers. If the equipment or subsystem does not contain transmitter, receiver, or amplifier, this requirement is not applicable and no verification is required.

C.3.3.1.1.3.1 CE106 Limits

The CE106 limits in this specification are the same as those in MIL-STD-461F.

C.3.3.1.1.4 Conducted Emissions, time domain, DC power levels, Transient and Steady State (CE107)

MSFC Technical Standard ES42		
Title: Electromagnetic Compatibility Requirements for Equipment and Subsystems	Document No.: MSFC-SPEC-521	Revision: C
	Effective Date: July 1, 2013	Page 72 of 75

The requirement is applicable for measurement of all turn-on and mode-switching transients. There have been several cases noted where energizing certain equipment has dropped bus potentials for durations of the order of 100 μ s, causing other equipment to malfunction. Complying with this requirement, and its complement, CS106, mitigates the risk of power bus incompatibilities due to turn on transients and mode switching.

C.3.3.1.1.4.1 CE107 Limits

The CE107 28Vdc limit in this specification allows a 28Vdc load to turn on a total bulk capacitance of 25 μ F without current limit. The 120 Vdc limit allows a 120Vdc load to turn on a total bulk capacitance of 100 μ F without current limit.

C.3.3.1.1.5 Conducted Emissions, Bulk Cable Emissions (BCE), 150 kHz to 200 MHz (CE108)

This requirement is applicable for equipment and subsystem interconnecting cables. The requirement does not apply at the transmitter fundamental frequencies.

Since the NASA vehicles and platforms do not use the electromagnetic spectrum below 200 MHz for the purpose of receiving RF signals, there is no reason to impose the RE102 limit below that frequency. Instead, a limit on cable common mode CEs is imposed from 150 kHz to 200 MHz. The purpose is to control cable-to-cable crosstalk while at the same time eliminating the need for waivers against an inapplicable RE102 limit.

The BCE limit, first imposed on Shuttle payloads and equipment, was designed to limit inductively coupled crosstalk to 1 mV over a frequency range of 150 kHz to 200 MHz. Any victim signal susceptible to millivolt or sub-millivolt level crosstalk will be shielded and the shield may be counted on to provide necessary protection to signals whose accuracy requirement is less than 1 mV.

C.3.3.1.1.5.1 CE108 Limits

The BCE limit contained in this specification is the same as that in SL-E 0002, Book 3, Volume 1.

C.3.3.1.2 Radiated Emissions (RE)

C.3.3.1.2.1 Radiated Emissions, magnetic field, 30 Hz to 100 kHz (RE101)

This requirement is specialized and is intended primarily to control magnetic fields for applications where equipment is present in the installation that is potentially sensitive to magnetic induction at lower frequencies. Most equipment is insensitive to the low levels defined in this limit unless the equipment specifically uses, senses, or measures low-frequency magnetic fields. Due to the time-consuming nature of the testing, this requirement should be imposed on

MSFC Technical Standard ES42		
Title: Electromagnetic Compatibility Requirements for Equipment and Subsystems	Document No.: MSFC-SPEC-521	Revision: C
	Effective Date: July 1, 2013	Page 73 of 75

the equipment only when necessary to protect magnetically sensitive equipment that may reside on the platform or vehicle.

C.3.3.1.2.1.1 RE101 Limits

The RE101 limits contained in this specification are derived from those imposed in ISS payloads.

C.3.3.1.2.2 Radiated Emissions, electric field, 200 MHz to 40 GHz (RE102)

This requirement is to protect antenna connected receivers from interference due to equipment generated unintentional radiated emissions. It is not complimentary to the RS103 limit.

C.3.3.1.2.2.1 RE102 Limits

The RE102 limit contained in this specification is a tailored version of the MIL-STD-461F RE102 limit for US Army and US Navy fixed-wing and rotary-wing aircraft. While that limit extends to 10 kHz, this limit begins at 200 MHz due to the fact that NASA vehicles and platforms do not use the electromagnetic spectrum below 200 MHz for the purpose of receiving RF signals.

C.3.3.1.2.3 Radiated Emissions, antenna spurious and harmonic outputs, 100 kHz to 40 GHz (RE103)

This requirement may be used as an alternative for CE106.

C.3.3.1.2.3.1 RE103 Limits

The RE103 limits contained in this specification are the same as those in MIL-STD-461F.

C.3.3.2 Equipment Susceptibility

The purpose of the susceptibility requirements is to determine the immunity of the equipment to the electromagnetic environment. During test planning, the hardware provider must determine susceptibility criteria to be used during testing. When the equipment exhibits susceptibilities during testing, it is important to determine the threshold of susceptibility.

C.3.3.2.1 Conducted Susceptibility (CS)

C.3.3.2.1.1 Conducted Susceptibility, power leads, 30 Hz to 150 kHz (CS101)

C.3.3.2.1.1.1 CS101 Limits

MSFC Technical Standard ES42		
Title: Electromagnetic Compatibility Requirements for Equipment and Subsystems	Document No.: MSFC-SPEC-521	Revision: C
	Effective Date: July 1, 2013	Page 74 of 75

This requirement is derived from SAE AS5698 ripple voltage requirements and is intended to prove equipment immunity against power bus ripple voltages generated by the source and other loads.

C.3.3.2.1.2 Conducted Susceptibility, negative transients, power leads (CS106)

C.3.3.2.1.2.1 CS106 Limits

This requirement is not the same as the MIL-STD-461F, CS106 requirement. The purpose of this requirement is to determine the immunity of the equipment against power bus voltage drops due to turn-on transients generated by other loads. The test limit simulates the turn-on transient of a 28 Vdc, 200W load with 50 μ F of bulk capacitance or a 120Vdc, 1.44kW load with 200 μ F of bulk capacitance.

C.3.3.2.1.3 Conducted Susceptibility, structure current, 60 Hz to 100 kHz (CS109)

C.3.3.2.1.3.1 CS109 Limits

This requirement has limited applicability to equipment and subsystems, especially scientific payloads that utilize the spectrum below 100 kHz and very low voltage sensitivities (below 1 μ V). For most equipment and subsystems, however, this requirement is not applicable and no verification is required.

C.3.3.2.1.4 Conducted Susceptibility, bulk cable injection, 10 kHz to 200 MHz (CS114)

This requirement is applicable to all interconnecting cables, including power cables. Due to size constraints and available antenna field patterns during RS103 testing, it is recognized that cabling cannot be properly excited to simulate platform effects at lower frequencies. The common mode injection technique replaced low frequency radiated susceptibility testing starting with MIL-STD-461D.

C.3.3.2.1.4.1 CS114 Limits

In the flat portion of the curve, the limit is equivalent to 20 V/m using the relationship of 1.5mA per V/m. This relationship is derived from actual measurements on aircraft.

C.3.3.2.1.5 Conducted Susceptibility, damped sinusoid transients, cables and power leads, 10 kHz to 100 MHz (CS116) [satellite payloads exempted].

C.3.3.2.1.5.1 CS116 Limits

MSFC Technical Standard ES42		
Title: Electromagnetic Compatibility Requirements for Equipment and Subsystems	Document No.: MSFC-SPEC-521	Revision: C
	Effective Date: July 1, 2013	Page 75 of 75

The damped sine waveforms can be induced in equipment and subsystems by external stimuli such as lightning or electromagnetic pulse or from electrical switching phenomena. The limits contained in this specification are the same as those found in MIL-STD-461F.

C.3.3.2.2 Radiated Susceptibility (RS)

C.3.3.2.2.1 Radiated Susceptibility, magnetic field, 30 Hz to 100 kHz (RS101)

C.3.3.2.2.1.1 RS101 Limits

This requirement has limited application and is intended to ensure that the equipment is immune to intentionally-generated, low frequency magnetic fields. For equipment and subsystems flying on platforms that do not have high field devices such as magnetic furnaces or high power transformers, the applicability of this requirement should be evaluated.

C.3.3.2.2.2 Radiated Susceptibility, electric field, 200 MHz to 40 GHz (RS103)

The purpose of this requirement to show immunity of equipment and subsystems to intentional transmitters located on the platform and on the ground. It is not complimentary to RE102 and there is implied relationship between the two requirements.

C.3.3.2.2.2.1 RS103 Limits

The 200 V/m limit encompasses the worst-case ground environment described in TOR-2012(1663)-1, Cape Canaveral Radio Frequency Environment: Eastern Range and the on-orbit environment described in JSC-CR-06070, Space Vehicle RF Environments. If the equipment or subsystem is installed on a vehicle or platform that provides 20 dB or more attenuation from external RF environment, the 20 V/m limit may be used.

Equipment and subsystems flying on platforms or vehicles with intentional transmitters operating above 18 GHz should perform the RS103 testing in the 18 GHz – 40 GHz range. Platforms and vehicles that operate in low earth, high inclination (52° or greater) orbits will be exposed to RF fields generated by ground sources in the 18 GHz – 40 GHz range. Equipment and subsystems mounted externally to platforms or vehicles operating in this region should perform the RS103 testing in the 18 GHz – 40 GHz range.