

MSFC-STD-531  
September 1978  
Supersedes  
50M05189  
October 12, 1972

HIGH VOLTAGE DESIGN CRITERIA

*12/13/78*  
*510*

GEORGE C. MARSHALL SPACE FLIGHT CENTER  
MARSHALL SPACE FLIGHT CENTER, ALABAMA 35812

HIGH VOLTAGE DESIGN CRITERIA

Prepared by:

<i>Robert A. White</i>		<i>9/6/78</i>
Robert A. White	Organization	Date
Electronics Development and Packaging Branch	EC42	

Approved by:

<i>Harrison Garrett</i>		<i>9/7/78</i>
Harrison Garrett	Organization	Date
Chief, Electronics Development Division	EC41	

Approved by:

		<i>9/7/78</i>
F. Brooks Moore	Organization	Date
Director, Electronics and Control Laboratory	EC01	

	<i>F. Kay</i>	<i>12/12/78</i>
Stress Approval	Materials Approval	

NOTICE: If Government drawings, specifications, or other data are used for any purpose other than in connection with a definitely related Government procurement transaction, the United States Government thereby incurs no responsibility nor any obligation whatsoever, and the fact that the Government may have formulated, furnished, or in any way supplied the said drawings specifications or other data is not to be regarded by implication or otherwise as in any manner licensing the holder or any other person or corporation, or conveying any rights or permission to manufacture, use, or sell any patented invention that may in any way be related thereto.

PART No.	HF	REVISIONS				
		ZONE	SYM	DESCRIPTION	DATE	APPROVAL

DISTRIBUTION

1. Initial Distribution made by  
S&E-ASTR-MT
2. Restrictions for Distribution:  
None

10-16-72  
RELEASE

SEE ENGINEERING RECORDS	TOLERANCES EXCEPT AS NOTED		ORIGINAL DATE OF DRAWING 10/12/72		High Voltage Design Criteria	GEORGE C. MARSHALL SPACE FLIGHT CENTER NATIONAL AERONAUTICS AND SPACE ADMINISTRATION HUNTSVILLE, ALABAMA
	DECIMALS	ANGLES	DRAFTSMAN	CHECKER		
	.000 ±	MACH ±	TRACER	CHECKER		
	.00 ±	FORMED ±	ENGINEER	ENGINEER		
	.0 ±	OTHER	SUBMITTED <i>[Signature]</i>			
	MATERIAL		H. M. Feather			
	HEAT TREATMENT		APPROVED <i>[Signature]</i>			DWG SIZE 50M05189
NEXT ASSY	USED ON		H. M. Feather		SCALE	UNIT WT
APPLICATION		FINAL PROTECTIVE FINISH				A
						SHEET 1 of 109

**PREFACE**

This document was prepared by Mr. William G. Dunbar of the Boeing Company, Seattle, Washington, as a design/test guideline document for MSFC and contractor personnel concerned with high voltage equipment and experiments which are to fly on the Skylab I mission. The document is also applicable to other programs requiring the use of high voltage equipment such as the High Energy Astronomical Observatory (HEAO), the Space Shuttle, etc.

Any questions or comments concerning this document should be addressed to the Test and Evaluation Branch, Electro-Mechanical Engineering Division, Astrionics Laboratory, Marshall Space Flight Center. The mailing address and telephone numbers are as follows:

**Mailing Address:**

S&E-ASTR-MT  
George C. Marshall Space Flight Center  
Marshall Space Flight Center, AL 35812 .

**Telephone Numbers:**

(205) 453-1042  
(205) 453-1043

## CONTENTS

	<u>Page</u>
Contents . . . . .	iii
1. INTRODUCTION . . . . .	1
2. GLOSSARY OF TERMS . . . . .	3
3. ENVIRONMENT . . . . .	12
3.1 Spacecraft Orbit . . . . .	12
3.2 Pressurization . . . . .	12
4. PRESSURE SENSING . . . . .	14
5. HIGH VOLTAGE DESIGN DATA . . . . .	15
5.1 References . . . . .	15
5.2 Operating Voltage Levels . . . . .	16
5.2.1 Zero to 50 Volts . . . . .	16
5.2.2 50 to 250 Volt Peak . . . . .	17
5.2.3 Voltages Over 250 Volt Peak . . . . .	18
5.3 Gaseous Breakdown . . . . .	20
5.4 Environment Contamination . . . . .	22
5.5 Materials Data Pamphlets . . . . .	25
5.6 Dielectric Strength . . . . .	26
5.7 Insulation Life . . . . .	27
5.8 Field Gradients . . . . .	29
5.9 Voltage Distribution in Gas-Solid Dielectrics . . . . .	29
6. DESIGN APPLICATIONS . . . . .	38
6.1 Solid Insulation . . . . .	38
6.1.1 High Voltage Conformal Coating . . . . .	38
6.1.2 Encapsulation . . . . .	39
6.1.3 Uninsulated Circuitry . . . . .	40
6.2 Wiring . . . . .	40
6.3 Packaging Encapsulation . . . . .	44
6.4 Components . . . . .	47
6.4.1 Resistors . . . . .	47
6.4.2 Connectors . . . . .	47
6.4.3 Wire Construction . . . . .	50
6.4.4 Transformers . . . . .	50
6.5 Circuit Boards . . . . .	50
6.5.1 Terminations . . . . .	50
6.5.2 Standoffs and Feed Throughs . . . . .	50
6.5.3 Flashover . . . . .	50

CONTENTS  
(cont.)

		<u>Page</u>
6.5.4	Dielectric Strength . . . . .	57
6.5.5	Creepage and Tracking . . . . .	57
6.6	Multiple Dielectric . . . . .	57
6.7	Hermetic Seals . . . . .	63
6.8	Insulation Life . . . . .	67
7.	TESTING . . . . .	70
7.1	Background . . . . .	70
7.2	Testing and Detection . . . . .	70
7.3	Equipment Testing . . . . .	71
7.3.1	High Voltage Testing . . . . .	71
7.3.2	Parts Tests . . . . .	72
7.3.3	Circuit Tests . . . . .	72
7.3.4	Systems Tests . . . . .	73
7.3.5	RF System Tests . . . . .	76
7.4	Facility and Environment . . . . .	80
7.4.1	Contamination . . . . .	80
7.4.2	Pressures . . . . .	82
7.4.3	Temperature . . . . .	83
7.4.4	Charged Particle Radiation . . . . .	83
7.4.5	Electromagnetic Radiation and Ionization . . . . .	83
7.5	Test Procedure . . . . .	83
7.5.1	Altitude Chamber Testing . . . . .	84
7.5.2	Life Testing . . . . .	85
7.6	Corona Detection Circuits . . . . .	86
7.6.1	Corona Detectors . . . . .	86
7.6.2	Detector Constraints . . . . .	87
7.6.3	Standard Corona Detection Systems . . . . .	92
7.7	Data Analysis . . . . .	96
7.7.1	Temperature Cycling . . . . .	100
7.7.2	Switching . . . . .	100
7.7.3	Prototype Tests . . . . .	103

FIGURE

5.3.1	Voltage Breakdown of Pure Gases as a Function of Pressure Times Spacing . . . . .	21
5.3.2	Voltage Breakdown, Corona and Malter Effects Shown for Points, Rods and Plates in Air . . . . .	23
5.4.1A	Typical Electrical Properties of Polyimide Film at 23°C and 50% Relative Humidity . . . . .	25A

CONTENTS  
(cont.)

<u>FIGURES (cont.)</u>	<u>Page</u>	
5. 5.2 A	Temperature Affects AC Dielectric Strength Type H Kapton Film . . . . .	26A
5. 5.2B	High Humidity Degrades the Dielectric Strength of Type H Kapton Film . . . . .	26C
5. 5.2C	Insulation Thickness Affects Dielectric Strength of Type H Kapton Film . . . . .	26C
5. 5.2D	Film Area vs Dielectric Strength of Type H Kapton . . . . .	26D
5. 5.2E	Effect of Frequency on Dielectric Strength . . . .	26E
5. 5.2F	Life as a Function of Voltage for Type H Kapton . . . . .	27A
5. 5.2G	Heat Reduces the Time for Kapton Type H Film to Fall to Half of Original Dielectric Strength .	27B
5. 6. 1	Equipotential Surfaces and Directional Lines For Equal, Opposite, and Infinitely Long Conductors . . . . .	30
5. 6. 2	Typical Field Plot of Conductors Showing Curvilinear Squares from Intersecting Equipotential and Field Lines . . . . .	31
5. 6. 3	Electric Field Lines Showing the Effect of Interelectrode Medium on the Shape of the Plotted Field, . . . . .	32
5. 6. 4	Electric Field Lines Between Conductors and From Conductor to Groundplate for Typical Conductors . . . . .	33
5. 6. 5	Corona and Maximum Voltage Stress Formulas . .	34
5. 7. 1	Two Capacitors in Series . . . . .	35
5. 7. 2	A Gas Filled Dielectric in Series With Two Solid Dielectrics . . . . .	36
5. 7. 3	A Solid Dielectric In Series with Two Gaseous Dielectrics . . . . .	37
6. 2. 1	High Voltage Conductor at One Atmosphere . . . .	41
6. 2. 2	Outer Jacket Rupture . . . . .	41
6. 2. 3	Center Conductor Delamination . . . . .	41
6. 2. 4	Vented High Voltage Wire . . . . .	43
6. 3. 1	Undesirable Encapsulation Voltage . . . . .	45
6. 3. 2	Desirable Encapsulation Volume . . . . .	46
6. 3. 3	Removable Encapsulated Packaging . . . . .	46
6. 3. 4	Open Construction Packaging . . . . .	46
6. 4. 1. 1	High Reliability Resistor . . . . .	48
6. 4. 1. 2	Space Qualified Resistor . . . . .	48

CONTENTS  
(cont.)

<u>FIGURES (cont.)</u>	<u>Page</u>
6.4.2.1 Air in Connectors . . . . .	49
6.4.2.2 High Voltage Connector Conceptual Design . . . . .	51
6.4.3.1 Normal Wire Construction . . . . .	52
6.4.3.2 High Voltage Wire . . . . .	52
6.4.3.3 Coaxial Configurations . . . . .	53
6.4.4.1 High Voltage Transformer . . . . .	54
6.5.1.1 Unacceptable Soldered Terminations . . . . .	55
6.5.1.2 Acceptable Terminations . . . . .	55
6.5.1.3 Acceptable Components Interconnection . . . . .	56
6.5.2.1 Acceptable Standoff Connection . . . . .	56
6.5.3.1 Flashover Strength of Several Materials . . . . .	58
6.5.3.2 Effect of Spacing on Flashover Strength . . . . .	59
6.5.3.3 Flashover Strength Comparison (KV) . . . . .	60
6.5.4.1 Breakdown Strength of Several Materials . . . . .	61
6.5.5.1 Definitions of Creepage and Clearance Spacing. . . . .	62
6.6.2 Voltage Distribution in Gas-Solid Dielectric . . . . .	64
6.6.3 Applying Material With Various Dielectric Constants . . . . .	65



## 1. INTRODUCTION

Electrical insulation and its application to high voltage systems has been investigated for several aerospace vehicles. These applications include communication systems and experiments for several unmanned and manned space vehicles, orbital, and re-entry vehicles; and modern commercial airplane electrical/electronics systems.

The electrical insulation systems and their proper application are historically not given completely adequate consideration by the designers of electrical and electronic equipment. This is due to the fact that many electronic system designers select insulating materials on the basis of vendor data. Often the importance of outgassing, thermal stressing and high voltage field stresses were neglected. Consequently, some hardware exhibited excessive crosstalk, and/or intermittent corona discharges which led to eventual insulation deterioration and finally voltage breakdown. This can result in either the partial or total loss of the spacecraft mission through the loss of primary systems or scientific telemetered data.

These past experiences have clearly indicated that the design requirements of aerospace electrical/electronic systems require more emphasis on proper insulation and its application. Specifically, the effects of temperature cycling, high density packaging, long mission durations and high voltage on materials must be analyzed by specialists when evaluating electrical insulation. The electrical designer alone can not be expected to do the complete insulation and electronic design. A team of technically qualified personnel must be assembled for the design analysis including: the electronic designer, a materials application engineer, a packaging specialist, and a test team, all under the guidance of the design specialist. This team must also consider the total composite environment in which the system must operate. For instance, some insulations are expected to operate in space vacuum after they have been subjected to several months shelf life in a relatively uncontrolled atmosphere on Earth. They may have been flexed, temperature cycled, vibrated, handled and even exposed to hostile fumes. These mechanical and chemical stresses in addition to an electrical stress can lead to the rapid deterioration and eventual breakdown of the insulation. The design team must be cognizant of the above mentioned aerospace environmental and operational requirements. Although the complete team will not be needed continuously for the long period from design through the test program, specialized members should be included in the early design and packaging phases of the program.

This report with References 5.1.1 and 5.1.2 provides a guide to the designer on the application of electrical insulation to selected electrical components such as resistor wiring, transformers and printed circuit cards. The documented material gives pertinent information on: spacecraft environments, electric fields, operating life, suggested design applications, packaging concepts and testing.

## 2. GLOSSARY OF TERMS

The characteristics of corona are described by defining corona and the various forms thereof. Indeed there are many definitions of corona. One definition describes corona as "the general class of luminous phenomena appearing, associated with the current jump to some microamperes at the highly stressed electrode preceding the ultimate spark breakdown of the gap". Other characteristic phenomenon and mechanisms associated with the manifestations of corona and high voltage breakdown are given below.

Apparent Corona Intensity - The apparent corona intensity is a measure of the individual charge redistribution in the specimen when a corona discharge takes place. The apparent loss of charge in coulombs may be obtained by multiplying the pulse height observed on the oscilloscope by a constant. The constant is the product of the capacitance of the specimen under test times the direct voltage required to produce unit pulse height when the specimen, or an equivalent capacitance, is charged and then discharged into the measuring circuit.

Arc - A self-sustaining electrical discharge in which the primary source of charged particles is by thermionic emission at one or both of the electrodes.

Attenuation - The reduction in strength of an electrical impulse, i.e. the power loss in a coaxial cable expressed as decibels per kilometer or decibels per 100 feet.

Breakdown (Puncture) - A breakdown is a disruptive discharge through insulation.

Brush Corona - A condition when corona luminosity extends into the interelectrode gap in the form of a fanned hair brush.

Cathode Potential Fall - The cathode fall is the non-glow discharge saturated current region just prior to glow. This is a safe criterion in establishing a maximum allowable potential difference between exposed electrical conductors in low pressure gas. The effect of different electrode materials can be very important in designing high voltage vacuum equipment.

Clumping or Malter Effect - The "Clumping" mechanism involves a charged particle of material being removed from an electrode by the field which accelerates it toward the opposite electrode. The impact energy produces enough localized heating to create a vapor cloud; the result is voltage breakdown.

### Clumping (Continued)

In the design of a successful high-voltage circuit for space use, the trapped gas, outgassing, and sublimation from nearby materials must be identified and where practical should be controlled. Insulation between electrodes must be so designed that critical voltage gradients are not exceeded. In vacuum gaps, the voltage is limited by emission phenomena. In dielectric insulation, gap lengths and size of inherent voids establish the allowable voltage gradients.

Corona - Corona is a luminous discharge (evidenced as a localized point at negative electrodes and as a thin film over high field areas of positive electrodes) due to ionization of the gas surrounding a conductor around which exists a voltage gradient exceeding a certain critical value. Corona is the visible deionization release of energy. As the electric field stresses the gas molecules, energy is absorbed as they separate to the charged atoms or ions. This energy absorption into gas is measurable as current. The deionization process or visual corona releases this absorbed energy as light.

Corona can also be defined as a partial discharge of the gas between two open or partially encapsulated electrodes which results in a momentary current flow of  $10^{-8}$  to  $10^{-6}$  ampere peak.

Corona Detection - Some positive means for detecting the presence of electrical discharges in equipment which is undergoing test should be employed. Visual observation of the glow usually (but not always) associated with a discharge is obviously not always possible, and the monitoring of the inputs and outputs of the equipment will not in all cases reveal the presence of a problem. Since a discharge in a gas almost always produces electrical "noise" over a fairly wide frequency spectrum, some form of wideband radio receiver, or a wide-band oscilloscope can be used as a detector. If the equipment is not shielded in its test configuration, a suitable pick up antenna or capacitance probe can be placed near the equipment. If it is well shielded (as recommended in most specifications and standards) it may be necessary to build in a pick-up device.

Corona Erosion - When the stress at the surface of solid insulation or in an internal gas void exceeds the breakdown value, the gas ionizes and becomes conductive. Since the solid insulation is not conducting, the current passing through the gas stops at the solid surface and charges it. When this happens, the discharge in the gas is extinguished. If the applied voltage continues to change, the gas or void will break down again with another temporary pulse. It is either external, if the discharge occurs on the surface of the insulation, or internal, if it occurs inside a crack or void. The electrons and ions bombard the void walls producing pits and form cavities termed traeing. By spreading the stress, conductive residues generally tend to reduce the corona intensity. After a reasonably long period, depending on the corona intensity, the insulation breaks down.

Corona Extinction Voltage - That voltage at which corona is extinguished, if the applied voltage is decreased, after corona is obtained.

Corona Onset Potential - That potential at which ionization by collision becomes a cumulative process; i.e., that potential at which self-sustained corona first starts. The corona onset potential is determined by increasing the applied voltage across the specimen until corona signals are noted on the screen of the cathode-ray-oscilloscope or other detector. The voltage is held constant at this value for a period of time (say 20 seconds), and it is noted whether or not the pulses are sustained. If the pulses are not sustained the voltage is increased in small increments until sustained corona is obtained.

Corona Starting Voltage - (See Corona Onset Potential).

Creepage - The conduction of charge along the interface of two dielectrics (a type of surface breakdown).

Creepage Surface - An insulating surface which provides physical separation as a form of insulation between two electrical conductors of different potential.

Crookes Dark Space - Near breakdown in air and other gases, though not readily observed, the negative glow increases in extent, and at lower pressures the Crookes dark space and a faint general glow extending to the negative electrode are all that is seen near the point where pulses cease.

Density - The number of gas molecules per unit volume.

Dielectric - A dielectric is a medium having the property that the energy required to establish an electric field is recoverable, in whole or in part as electric energy. A vacuum is a dielectric.

Dielectric Breakdown - A condition that occurs when the voltage gradient in a gas is high enough to accelerate electrons within their mean free paths such that they have enough energy to ionize an atom at collision creating an avalanche of charged carriers with sufficient energy to evaporate electrode material and to sustain the discharge at voltages as low as 20 volts.

Dielectric Constant - (Specific Inductive Capacity) - The dielectric constant is that property which determines the electrostatic energy stored per unit volume for unit potential gradient.

Dielectric Strength - The voltage which an insulating material can withstand before breakdown occurs, usually expressed as a voltage gradient (such as volts per millimeter).

Dielectric Tests - Dielectric tests are tests which consist of the application of a voltage higher than the rated voltage for a specified time for the purpose of determining the adequacy against breakdown of insulating materials and spacings under normal conditions.

Discharge - Any conducting mechanism between two electrodes separated by a dielectric.

Electric Field - The space rate of change of electrical potential gradient that the material can withstand without rupture. The value obtained for the electric strength will depend on the thickness of the material and on the method and conditions of test.

Electric Field Line - A field line exists when a smooth curve or straight line can be drawn between an energized electrode and a ground plane or between oppositely charged electrodes.

Electric Strength (Dielectric Strength, Disruptive Gradient) - The electric strength of a dielectric material is the maximum potential gradient that the material can withstand without rupture. The value obtained for the electric strength will depend on the thickness of the material and on the method and conditions of test.

Electrical Spacing - Electrical spacing for corona calculations is determined by the shortest and longest electric field lines between a conductor and a ground plane.

Electrode - An electrode is a conductor, not necessarily metal, through which a current enters or leaves an electrolytic cell, arc, furnace, vacuum tube, gaseous discharge tube or any conductor of the non-metallic class.

Electron Avalanche - A cone-shaped cloud of electrons with apex towards the cathode and axis in the direction of the field.

Flashover - A flashover is a disruptive discharge around or over the surface of a solid or liquid.

Field Emission - Field emission is the current emitted from an electrode as a function of: the electrode area and thermionic work function, the voltage gradient, and the electrode temperature.

Gap-Bridging Streamer - A streamer which spans completely from one electrode to another electrode or to a barrier which arrests the further progress of the streamer.

Glow Corona - A term given to that corona which in appearance is a visual glow of indefinite shape.

Glow Discharge - A self-sustaining electrical discharge in which the primary source of charged particles is due to ionization of molecules by collisions. At low pressure the luminosity is general and diffuse over the surface of the electrodes.

High Voltage - Any voltage above 250 volts dc or ac (peak).

Impulse - A surge of unidirectional polarity.

Impulse Corona - Corona produced by use of an impulse voltage wave. A standard test wave has a rise time of 1.5 microseconds and fall time of 40 microseconds.

Impulse Ratio - The impulse ratio is the ratio of the flashover, sparkover, or breakdown voltage of an impulse to the crest value of the power frequency flashover, sparkover, or breakdown voltage. Calculated using the equation:

$$B = 1 + \frac{0.8}{\sqrt{t}} \quad \text{where } B = \text{Impulse Ratio} \\ t = \text{Pulse Duration (micro sec.)}$$

Initiating Streamer - The first streamer from which subsequent formation of the corona mechanism begins.

Insulation Arc-Over - Insulation arc-over is a discharge of power current in the form of an arc following a surface discharge over an insulator.

Insulation Tracking - Formation of permanent low resistance path on the surface of a solid dielectric following flashover at the surface. Formation of track is governed by the type of material and moisture or other contaminants on the surface.

Intrinsic Electric Strength - That electric field strength which is characteristic of the dielectric and which is independent of other factors except its physical state. The unit of Intrinsic Electric Strength is volts/meter.

Insulator - An insulator is a material of such low electrical conductivity that the flow of current through it can usually be neglected.

Low Voltage Tracking - Conduction paths established by tracking which may arise from thermal decomposition at discontinuities in a semi-conducting surface without the intervention of a macroscopic discharge. Low voltage tracking may occur at voltages less than the minimum breakdown voltage of the ambient medium.

Malter Effect of "Clumping" - A field emission caused by surface charges on an impure cathode. These so-called surface charges can be caused by photons from preceding discharge or from an outside source.

Mean-Free Path - The average distance between collisions of molecules in a gas.

Momentary Flashover - Short duration arcing between electrodes usually not of a sustained or corona nature.

Multipactor - Breakdown in hard vacuum at frequencies (RF) by secondary emission at the electrodes. The mechanism is caused by electrons being accelerated between two plates connected to an RF source. For the multipactor effect to occur, the mean-free path of the electrons must be sufficiently long to allow the accelerated electrons to strike the plates alternately in phase with the RF voltage. The mean-free path is a function of gas density. In striking the plates, secondary emission must increase the number of oscillating electrons with each succeeding cycle. The existing voltage must be of specific amplitude and phase to cause a polarity reversal at the moment of electron impact with each plate at that particular spacing. To generate sufficient electrons, the secondary emission of the plate material must have a product greater than unity.

Negative Point Corona - That corona at the point of a point-to-plane experimental voltage configuration, which point is maintained at negative potential.

Normal Temperature and Pressure - A temperature of 20°C and a pressure of  $1.01 \times 10^5 \text{ N/m}^2$  (760 torr).

Partial Discharge - A type of localized discharge resulting from transient gaseous ionization in an insulation system when the voltage stress exceeds a critical value. The ionization is localized over only a portion of the distance between the electrode of the system. The resultant partial discharge signals appear as very small magnitude, fast-rise pulses with irregular wave shapes



superimposed on the high-voltage at the terminals of the test sample. This discharge causes insulation deterioration and is a primary cause of insulation failure.

Partial Voltage Breakdown - That condition in which an electrical discharge occurs between two electrodes but at which electrical discharge does not at any time cause a voltage breakdown.

Paschen Law - For all gases and gas mixtures, there is a minimum voltage between electrodes below which electrical breakdown in the form of an avalanche discharge will not occur resulting in corona or voltage breakdown. For potentials above this minimum, determination of the voltage required for the initiation of the avalanche discharge is based on the Paschen curve for the gas or gas mixture, modified to take into account non-uniform fields and insulation systems of gaseous and solid materials. The initiation voltage is a function of gas density and the width of the gap separating the electrodes, as well as other factors including the presence of solid insulation on the conductor within the gap.

Peak Voltage - The maximum transient voltage that can be experienced by the circuit at any time.

Positive Point Corona - That corona at the point of a point-to-plane experimental configuration, which point is maintained at positive potential.

Relative Corona Intensity - When a voltmeter is connected to the output of the amplifier the reading of the meter is proportional to the magnitude of the corona signals and the number of pulses occurring per unit of time. The readings from the output meter are referred to as the relative corona intensity and are generally given versus the applied voltage.

Restrike - Any gap-bridging streamer which occurs after the first gap-bridging streamer.

Self-Sustaining Discharges - Discharges which are independent, once initiated, of external sources of electrons.

Spark - A discharge in which an arc-like channel develops through the gas but is not sustained long enough to be stabilized by the effect of the electrodes or external circuit.

Spark-Over - A spark.

Step or Stepped Streamers - One or more streamers which follow after the initiating streamer in a manner of successive discrete steps.

Streamer Corona - Electrical discharge evidenced by finger like glow between electrodes during thermionic emission.

Surface Breakdown - The development of conducting channels between two electrodes on a dielectric surface.

Surface Leakage - Surface leakage is the passage of current over the boundary surfaces of an insulator as distinguished from passage through the volume.

Tan  $\delta$  - Loss tangent, the ratio of loss current to charging current.

Testing - High Voltage (AC) - Voltage endurance as a function of test time: the voltage a test sample can stand depends to a great extent on the length of time that voltage is applied. This relationship is not linear, but has the general characteristic that, if the voltage is lowered slightly, the withstand time is greatly increased. AC Testing is usually considered a go/no-go type of proposition. Voltage is run up to a specified value; if the sample breaks down, it is no good; if it does not break down, it is assumed good.

Testing - High Voltage (DC) - Leakage current is measured as voltage is raised, as long as current varies approximately linearly with voltage, the equipment is considered good. In most cases (this depends on the particular insulation materials involved) there will be a knee in the curve of voltage-versus-current. Prior to breakdown as the breakdown point is approached, the leakage current starts increasing at a higher rate, followed by an avalanche current. On certain newer materials, this knee is almost a right-angle bend; breakdown is reached at about the same time the first sign of the knee appears. The material is considered no good if operated at voltages above the linear portion of the curve.

Thermionic Emission from Hot Surfaces - Thermionic emission, the electron or ion emission due to the temperature of the emitter, depends on the emitter being hotter than 500°C and the existence of a sufficiently high voltage gradient. Sparks or corona streamers generated at small projections on the cathode surface can increase the local temperature sufficiently to produce thermionic emission.

Tracking - The development of conducting channels wholly or mainly in the dielectric surface, which surface suffers damage in the process.

Transverse Breakdown - Voltage breakdown of an insulating material in a direction perpendicular to the direct distance between two electrodes or perpendicular to the direction of the electric field between the two electrodes.

Treeing - A cumulative type of failure which results in pits or hollow channels that branch slowly through insulation materials until complete penetration occurs. The condition exists at stress voltage gradients as low as 2000 volts/millimeter.

Trichel Pulse Threshold - The output current is pulsating or intermittent in nature. Depending on the geometry and the spectrographic nature of the gas, the intermittent or pulsed thresholds may not show luminosity in all cases. If the voltage is raised sufficiently above the threshold, the frequencies of the intermittent output pulses become so great that they merge to a nearly steady but slightly fluctuating current.

Units

Low Vacuum:  $1.01 \times 10^5 \text{ N/m}^2$  to  $1.0 \times 10^2 \text{ N/m}^2$

Medium High Vacuum:  $1.0 \times 10^2 \text{ N/m}^2$  to  $1 \times 10^{-1} \text{ N/m}^2$

High Vacuum:  $1.0 \times 10^{-1} \text{ N/m}^2$  to  $1.0 \times 10^{-5} \text{ N/m}^2$

Very High Vacuum:  $1.0 \times 10^{-5} \text{ N/m}^2$

Voids in Encapsulants - The only effective way to determine whether a complete void-free coating has been achieved is to test the equipment in a vacuum chamber at a pressure of about  $1 \times 10^{-6} \text{ N/m}^2$  and check for signs of corona or insulation breakdown using suitable detection methods.

Visual Corona Point - If conductor potential is gradually increased, it is that voltage at which a hissing is heard, and if it is dark, a pale violet light can be seen close to the surface of the conductor.

Voltage Breakdown - The temporary or permanent loss of normal insulating properties. Voltage breakdown results when the dielectric material deteriorates or when a material with insufficient dielectric strength has been used.

### 3. ENVIRONMENT

Spacecraft electronic equipment must be designed to sustain the rigorous stresses of the space environment and time. Usually the specification for spacecraft electronic equipment is written as though the equipment were mounted on the exterior surfaces of the spacecraft and the spacecraft were to operate under static conditions throughout the mission. This concept is inadequate for the high voltage electrical/electronic equipment design, since the spacecraft is normally a dynamic vehicle which changes conditions with time. Thus, some pressure buildup within and outside the spacecraft is inevitable.

3.1 Spacecraft Orbit - Some initial design constraints that must be considered when developing a high voltage design are those regarding the mission and orbit. These include:

- . Mission Duration
- . Equipment Turn-On/Turn-Off Times
- . Orbit Altitude Throughout the Mission
- . Initial Orbit Pressure Within the Spacecraft and on the Spacecraft Surface
- . Peak Spacecraft Orbital Transient Pressure
- . Duration of Pressure and Voltage Transients
- . Equipment Operating Time

During the mission the gaseous environment inside the spacecraft will normally be greater than that immediately surrounding the spacecraft. This increased pressure is typically due to: life support systems leakage, materials outgassing, equipment purging, equipment leakage and the operation of the reaction control devices. This pressure differential should be stabilized within one week in orbit. This long pressure delay period is due to the slow outgassing of items like thermal blankets, experiments, and spacecraft equipment. During the thermal vacuum test of the Skylab Apollo Telescope Mount the measured pressure near experiment packages was as much as two orders of magnitude greater than the pressure level achieved within the space chamber.

3.2 Pressurization - Certain equipment or volumes may contain pressurized gases such as: argon, carbon dioxide, helium,

nitrogen, methane, propane or xenon. Most of these gases have ionization potentials similar to or less than that of air at the same pressure. However, argon and helium have much lower ionization potentials than air at the same pressure. Thus corona can be initiated in argon and helium at approximately 50 percent lower voltage than that required in air. When conditions exist where a gas with a low ionization potential is used to partially pressurize the spacecraft, it is necessary that the high voltage systems and components be designed to operate in an atmosphere closely resembling the spacecraft atmosphere to ensure an adequate margin of safety. For instance, if a high voltage circuit is required to operate near a vessel which outgasses argon, then the high voltage circuitry should be designed to operate in a depressurized argon atmosphere. This would also require verification testing of the engineering development models in an argon atmosphere. If any items are leak-tested or pressurized with either helium or argon after a corona susceptible analysis, then these items must be reanalyzed to be certain that the item is not influenced by the pressurizing atmosphere.

#### 4. PRESSURE SENSING

Some equipment is pressure sensitive and is designed to operate only at high vacuum, for example at pressures less than  $1.33 \times 10^{-3} \text{ N/m}^2$  ( $1 \times 10^{-5}$  torr). Therefore, it is recommended that pressure switches be installed in the flight vehicle to shut down the experiment at higher pressures, i.e. pressures greater than  $1.33 \times 10^{-3} \text{ N/m}^2$  ( $1 \times 10^{-5}$  torr).

When pressure sensors are installed near equipment containing gases other than air, the pressure sensors may require calibration in a gaseous mixture similar to that anticipated in operation. For instance, the continuous leakage of gas A and the purging of gas B and/or gas C may result in a unique mixture which may require the pressure sensors to be calibrated for that particular gaseous mixture.

Placement of the pressure sensors may be difficult. First, the number of pressure sensors will be limited, and second, each piece of equipment may have a requirement for pressure sensing within the equipment near the critical components. Therefore it may be necessary that at least two groups of pressure sensors be installed within the spacecraft: one group to monitor the pressure in the vicinity of the spacecraft high voltage equipment and adjacent equipment and the other group centrally located inside the spacecraft to monitor the pressure surrounding the equipment in that sector of the spacecraft. A pressure analysis will be required to determine which segments of the spacecraft have the highest pressure before the exact location can be determined.

Pressure sensitive equipment will need to be deenergized as rapidly as possible if a pressure surge occurs. There should be a requirement that the pressure sensors have inputs to the power system automatic control system if one exists, so that the pressure-sensitive equipment can be turned off in time to prevent permanent damage. Override control circuitry should be installed to compensate for a failed pressure sensor circuit.

## 5. HIGH VOLTAGE DESIGN DATA

This section contains some high voltage design data pertinent to corona free component selection and electronic packaging.

### 5.1 References

5.1.1 Bunker, E. R. Jr., "High Voltage Electronic Packaging Flight Equipment", Jet Propulsion Laboratory, DM 505139, November 24, 1971.

This document covers the design requirements for the protection of high voltage flight equipment from damage due to arcing or corona breakdown. Tests, test equipment and test requirements are discussed for spacecraft electronic components, parts and subsystems.

Note: Paragraph 4.4.4.12 of DM 505139 states: "Monitoring for voltage breakdown is required by one of the following methods:

- a. Suitable corona detection equipment;
- b. Inherent capability of the subsystem to detect corona;
- c. By visual means."

An exception is taken to "By visual means". Corona on exposed circuitry can be detected by visual means at pressures down to  $1.33 \text{ N/m}^2$  ( $1 \times 10^{-2}$  torr). For pressures less than  $1.33 \text{ N/m}^2$  ( $1 \times 10^{-2}$  torr), electronic detecting techniques are necessary.

5.1.2 Paul, F. W. and Burrowbridge, D., "Prevention of Electrical Breakdown in Spacecraft", Goddard Space Flight Center, Greenbelt, Md. NASA SP-208, 1969.

The methods for preventing electrical breakdown in space flight are discussed. The techniques that have been evolved by several successful users of high-voltage systems in space are given in detail. Fundamental elements are the avoidance of high intensity electric fields and the avoidance of critical gas pressures. Selection of materials, cleanliness, good mechanical design, solid potting or excellent venting and efficient testing are the steps to success.

5.1.3 Kreuger, F. H., "Discharge Detection in High Voltage Equipment", American Elsevier Publishing Company, New York, N.Y., 1965.

5.1.4 Loeb, L. B., "Electrical Coronas," University of California Press, Berkley and Los Angeles, California, 1965.

5.1.5 Meek, J. M. and Craggs, J. D., "Electrical Break-down of Gases," Claredon Press, Oxford, London, 1953.

5.2 Operating Voltage Levels - When appropriate conditions exist, corona can occur at any voltage level. For purposes of this discussion, three voltage ranges have been categorized to help justify the designer in his elimination of some designs from the corona susceptible category and to permit value engineering techniques to be used for time savings and a more cost-effective corona assessment program. These are 0 to 50 V, 50 V to 250 V, and over 250 V.

5.2.1 Zero to 50 Volts - The first voltage range is 50 volts and below. Field stresses normally will be below 2000 v/mm since the insulation is normally thicker than 0.025 mm. Corona due to gaseous ionization will not exist in air or nitrogen atmospheres between commonly used metallic surfaces at temperatures below 250°C. In addition tracking is not expected in this voltage range provided the following good workmanship practices are followed during design, packaging, and assembly:

- a. Avoid contamination on surfaces of conductors and their insulations.
- b. Select materials and dimensions that can withstand the worst-case voltage gradients around the energized conductors.
- c. Avoid short air gaps between thinly-insulated or bare conductors.
- d. Select insulating materials with maximum resistivity and dielectric strength and with low dielectric constant.
- e. Apply the Paschen Law curve as modified for non-uniform fields. A Paschen Law curve is shown in Figure 5.3.2.
- f. Base all calculations on the instantaneous peak "abnormal overvoltage" of the system.
- g. Select materials with suitable outgassing properties.
- h. Select packages with adequate sealing or venting.



Strict observance of these items will assure that gaseous breakdown will not occur at temperatures below 250°C.

The type of problems that can be expected if proper care is not taken are:

- a. Low voltage tracking where the extremely low current (nanoamperes) will eventually char the insulation.
- b. Metal migration can occur over extended operating times. This results in a short circuit when the metal from one electrode bridges the gap between electrodes.
- c. Contamination due to salt spray, outgassing residues from other spacecraft equipment, structure and controlled emissions.
- d. Short circuits due to workmanship, caused by fingerprints and oils, can create localized critical pressures which may affect nearby high voltage circuitry.

5.2.2 50 to 250 Volt Peak - The second voltage range is between 50 volts and 250 volts peak. In this range, besides the above stated good workmanship practices and precautions, the following practices will minimize the probability that corona will occur:

- a. Eliminate dielectric discontinuity. That is, avoid a sudden increase in voltage stress between insulators due to use of insulators with large difference in dielectric constant.
- b. Recess terminals and encapsulate with void-free, well-bonded surfaces, and potting materials.
- c. Use non-tracking insulations, such as teflon and glass.
- d. Prevent condensations of moisture and other liquids prior to operation and during operation.
- e. Lengthen flashover paths when practical with skirts, grooves, etc. See Figure 6.5.5.1.
- f. Avoid pointed electrodes.
- g. Provide excellent bonds between conductors and insulators.
- h. When hermetic sealing is required, pressurize with a suitable dry gas with a high dielectric strength in a thoroughly dry enclosure.

- i. Use low dielectric constant insulators.
- j. Dampen inductive switching surges.
- k. Design for abnormal fault and transient voltages.
- l. Waterproof insulating surfaces.
- m. Complete coating of critical electrodes may eliminate electrode-to-electrode breakdown but the spacing must be sufficient to prevent corona for dc voltages.
- n. Avoid multipactor by having a high "frequency times spacing" product.
- o. Arrange conductors so that high and low voltage groups are separated.
- p. Provide rounded corners on electrical conductors and ground planes next to energized circuits.
- q. Use at least 0.25 mm insulation between rounded electrodes and 1.25 mm between flat surfaces.

5.2.2.1 Typical problems in this voltage range that can occur are:

- a. Corona may be enhanced by gases such as helium, argon, neon and hydrogen, if they should be mixed with the pressurizing gas in pressurized containers during such operations as leak detection.
- b. Be careful in the use of solvents such as alcohol, benzene, etc. Their outgassing products enhance corona.
- c. Creepage and tracking can cause increased temperatures in localized areas and eventually lead to surface flashover.
- d. Voltage transients may cause surface flashover to occur. Between 6 and 10 flashovers will form tracking and eventually voltage breakdown.

5.2.3 Voltages Over 250 Volts peak - The third voltage range is all voltages above 250 volts peak or those with RF in the multipactor range. Some design features in addition to the good workmanship practices and precautions which are stated in 5.2.1 and 5.2.2 which are recommended to inhibit corona for voltage above 250 volts are:

- a. Avoid multipactor region.
- b. Eliminate large air gaps between insulated conductors. An example is a twisted pair wires having an end flare as they enter the terminal ports. As voltage is increased, corona will first appear at the widest separation in the low pressure systems (below  $1.33 \times 10^{-1} \text{ N/m}^2$ ).
- c. Application of transverse magnetic fields to raise the sparking voltage at pressures below the critical pressure. Since the effect is to increase the gap length due to spiraling of electrons, breakdown voltage can be lowered, rather than raised, below the critical value of the parameter, pressure times spacing dimension.
- d. Avoid the entry of ionized particles or electrons into the circuitry from the surrounding environment. The importance of the presence of such particles is evident from the OSO-I and OSO-II experiments which used open photomultipliers. Any electric field which may extend from openings in the enclosure will attract charged particles of one polarity. Suitable shielding grids and/or traps must be provided. Also high voltage on conductors in the vicinity of the openings must be avoided if possible.
- e. Voids in encapsulants are especially bad and should be vented or kept pressurized. When poorly vented voids or gas enclosures are encapsulated in an insulation, the gas pocket will eventually reach critical pressure and electrical breakdown will occur in the void. In time, insulation deterioration will occur and the insulation integrity will be destroyed, resulting in the loss of equipment.
- f. The use of semi-conducting coatings on high voltage surfaces and around stranded wiring can be used to control uniformity of fields.
- g. Use electrode materials which are conditioned and polished to most effectively decrease the voltage gradients within the insulation.

5.2.2.2 Above 5000 volts hermetic sealing may be required for some circuits that must operate at pressures greater than  $1 \times 10^{-2} \text{ N/m}^2$ . In this case it is advisable to use a gas with a high dielectric strength rather than oil. With oil, bubbles can form in "zero-g" which results in momentary dielectric breakdown and tracking. Pressurization is important above 10,000 volts to prohibit critical

pressures caused by slowly outgassing materials and nearby equipment. Materials compatibility is very important at these very high voltages.

Typical problems that can occur in this voltage range are:

- a. Incomplete bonding of materials.
- b. Insufficient outgassing of potting compounds during vacuum impregnation.
- c. Insulation cracking during thermal /mechanical stressing.
- d. Gaseous ionization and partial discharges within small voids and cracks.
- e. Creepage and tracking.
- f. Flashover.
- g. Insulation treeing on long missions.

5.3 Gaseous Breakdown - Corona manifests itself between energized electrodes either by a luminous glow in soft vacuum or as a small current in hard vacuum. Such corona phenomena result from localized critical gradients. Ultimately a spark or arc carrying larger current forms if the critical gradient progresses across the whole spacing. Electrical discharges in gases, including corona, follow Paschen's Law, which states that breakdown voltage is a function of the parameter, gas pressure times effective electrode spacing. Based on Paschen's Law, voltage breakdown and Corona Onset Voltage (COV) data for bare and insulated conductors has generally been presented either as a function of gas pressure multiplied by effective conductor spacing, or as a function of gas pressure between fixed-spaced electrodes.

The voltage breakdown as a function of gas pressure times spacing is shown for several gases in Figure 5.3.1. It should be noted that the Paschen Law curve differs for each gas and gas mixture. In addition the minimum COV differs with the pressure times spacing dimensions for each gas and gas mixture. These data were measured between parallel plates at 23° C for spacings of 1 millimeter to 10 centimeters at 400 Hertz. Little deviation was found between data published by various experimentors and that measured in the laboratory by the author.

In addition, the voltage breakdown and COV were measured between parallel plates, round (0.4 cm. dia.) rods and needle

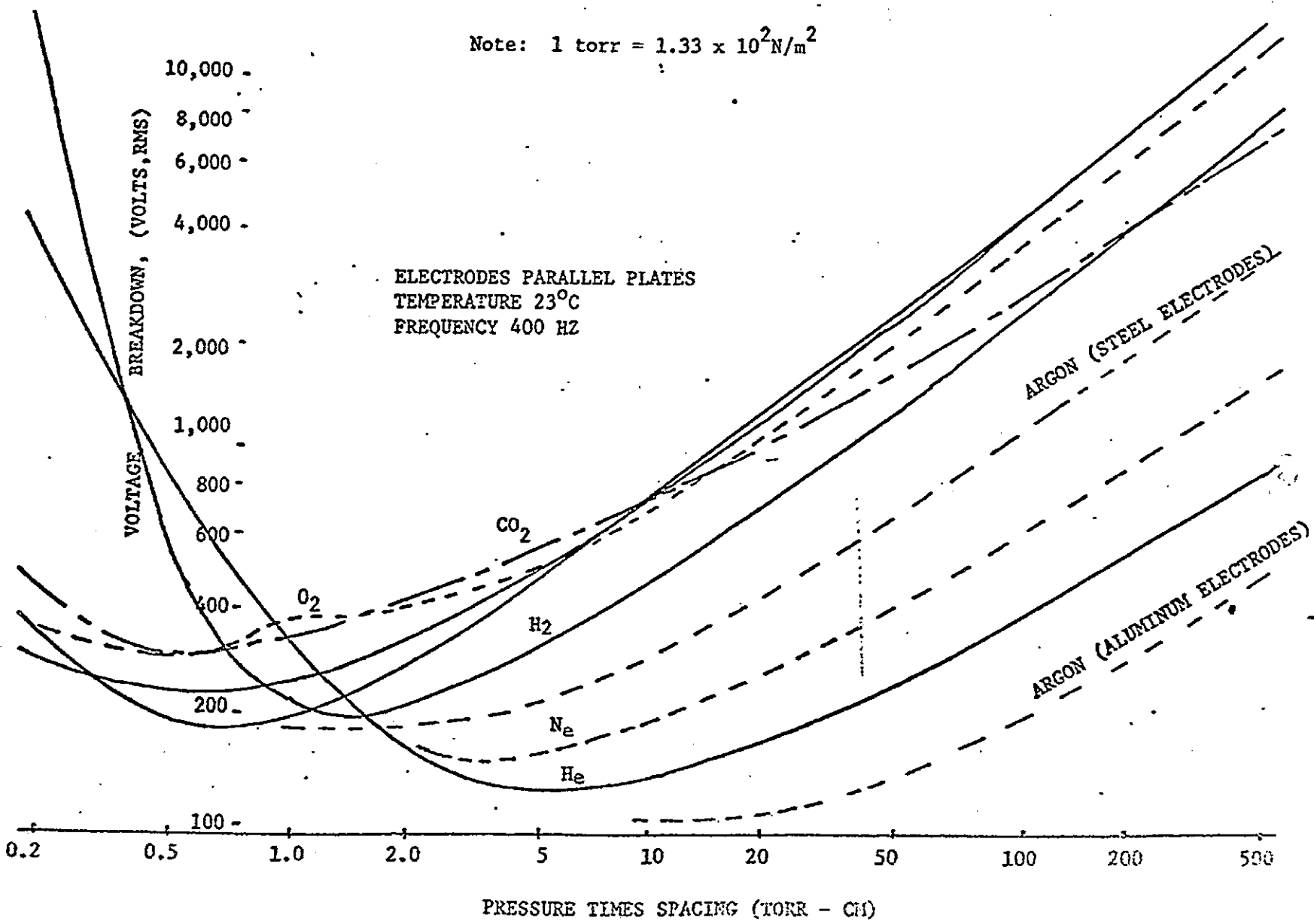

FIGURE 5.3.1 VOLTAGE BREAKDOWN OF PURE GASES AS A FUNCTION OF PRESSURE TIMES SPACING

points. In the glow discharge region the alternating current voltage breakdown and alternating current corona onset voltage occur simultaneously for points, plates and rods at 400 Hertz.

Corona occurs at different voltages for square edged rods and points at pressure times spacings greater than  $700 \text{ N/m}^2$ -centimeters in air as shown in Figure 5.3.2. When oxidized electrodes or contaminated electrodes are energized in hard vacuum the Malter effect will decrease the effective voltage breakdown.

5.4 Environment Contamination - Environmental factors which affect the corona and voltage breakdown of a gas are temperature, charged particle radiation, ultraviolet irradiation, and particulate (space or spacecraft debris) contamination. Other contributing factors include: electrode materials, electrode shape and finish, electrical insulating materials, the electrical field stresses, electrode spacing, and the applied voltage.

Particulate contamination can be in many forms such as foreign gasses, dust particles, oxides, and salts. For instance, entrapped helium effectively reduces the COV. Helium sometimes is added to a high voltage pressurized box during leak detection. If mechanical or electrical stressing should cause the insulation to crack internally, the crack can fill with helium rather than nitrogen or other pressurizing gas. When the helium partial pressure is between  $13.3 \text{ N/m}^2$  ( $1 \times 10^{-1}$  torr) and  $2.66 \times 10^3 \text{ N/m}^2$  (20 torr) it is subject to ionization, resulting in corona and insulation failure.

Dust particle contamination can be a problem source within a device as it can create stress in a local area, develop tracking, and eventually act as a point electrode. Likewise, oxides and salts present in the launch site environment and during the assembly, storage and transportation can deposit on the surface of the insulating materials. Eventually these deposits will change the condition of the electrodes by lowering the electronic work function of the metal. Thus corona will be generated at much lower potential. A typical breakdown value in vacuum for selected pure metals is listed in Table 5.4.1. The effect of electrode materials in an argon atmosphere is shown in Figure 5.3.1 for steel and aluminum parallel plate electrodes. Contaminated electrodes would have much lower breakdown voltages than that of pure metals and alloys. Depending upon the degree of contamination the breakdown voltage could be one order of magnitude less.

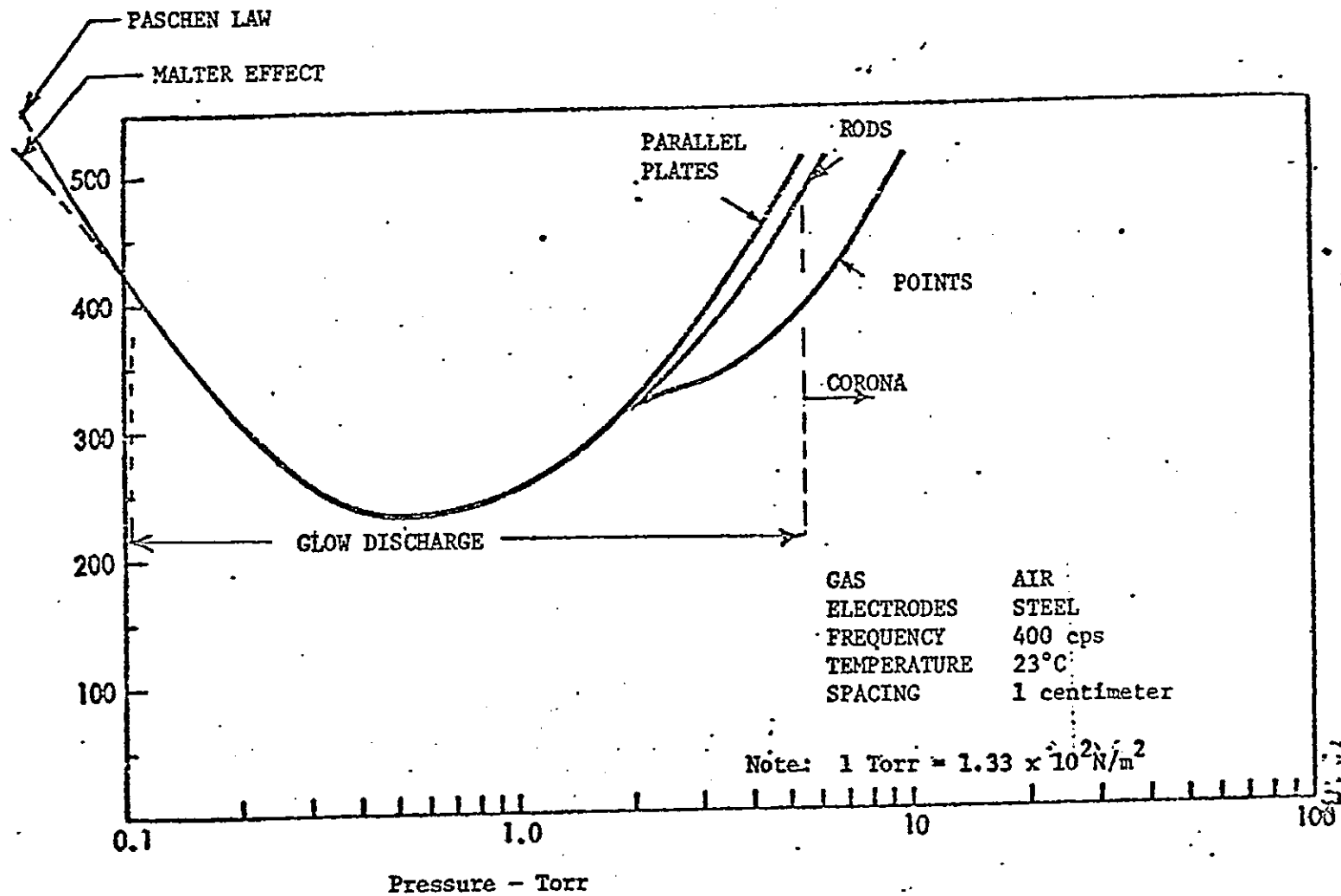

FIGURE 5.3.2 VOLTAGE BREAKDOWN, CORONA AND MALTER EFFECT SHOWN FOR POINTS, RODS AND PLATES IN AIR

Table 5.4.1: Vacuum Breakdown of Various Metal Electrodes

<u>Material (Polished Surfaces)</u>	<u>Vacuum Breakdown Voltages*</u> (Kilovolts for 1 mm gap)
Steel	122
Stainless Steel	120
Nickel	96
Aluminum	41
Copper	37

\* Pressure less than  $1 \times 10^{-3}$  N/m<sup>2</sup>; Values are minimum test breakdown voltages recorded

Another mechanism that affects COV is a conducting plasma such as that generated by a nearby arc or solar/space charged particles and those within radioactive or nuclear fields. When a gamma emitting isotope is used as an ionizing material, it affects corona in three ways: first, it lowers the corona onset voltage slightly; second, it raises the intensity of the intermittent corona; and third, it may alter the mechanical and electrical properties of the insulation to make the material more or less corona resistant. Irradiated polyethylene is an example of a material which is changed by radiation to be more corona resistant. Its increased corona resistance after irradiation results from an increase in ability to shrink and bond to itself to form a structure with fewer voids. Ultra-violet and infra-red radiation, when intense and/or prolonged, have degrading effects on materials.

Charged particle radiation of all types tend to reduce the COV. As an example: electrodes having a minimum COV of 325 volts at a total charged particle fluence of  $10^{10}$  e/cm<sup>3</sup> (electrons per cubic centimeter) will be reduced to 175 volts at  $10^{14}$  e/cm<sup>3</sup> and to 125 volts at  $10^{15}$  e/cm<sup>3</sup>. Thus, spacecraft with missions that expose equipment to high charged particle fluence levels must include protection for the sensitive devices from that environment.

Normally, the gas pressure of deep space contains few charge carriers and the mean-free path far exceeds the gap distance of electrodes. Here "vacuum" is a good insulator. In most



spacecraft however, this vacuum does not exist due to gas atoms and charged carrier contamination from the following sources:

- a. Outgassing from nearby materials
- b. Sublimation of nearby surfaces
- c. Trapped air within the components
- d. Gas-filled voids in insulation
- e. Spacecraft leakage gases

This contamination causes the interelectrode gap to approach the minimum COV from the high vacuum side of the Paschen Law curve. Most of the above factors are minimized during design and manufacturing control. However, it is imperative that the designer have a detailed specification defining the spacecraft pressure/temperature profile in the vicinity of the sensitive equipment, for the mission to permit worst case design considerations which assure a corona-free system design.

5.5 Materials Data Pamphlets. When selecting an insulating material for a high voltage application, the right data seems to be hard to find. Mechanical and chemical data are usually abundant but too often the available electrical data is a simple tabulation of constants, with no hint of how these constants will vary. Most published data needs to be adjusted or translated into the application at hand.

The electrical properties of polyimide film (Kapton) are shown in Table 5.4.1A. These variations in dielectric strength, dielectric constant, dissipation factor, volume resistivity, surface resistivity, and corona susceptibility are described below for Kapton H, a DuPont polyimide which is often used as a high-voltage insulation in aircraft. Throughout this paragraph English units of measurement are used to preserve consistency with the manufacturer's published data sheets.

TABLE 5.4.1A

TYPICAL ELECTRICAL PROPERTIES OF POLYIMIDE FILM AT  
23°C AND 50% RELATIVE HUMIDITY

<u>PROPERTY</u>	<u>TYPICAL VALUE</u>	<u>TEST CONDITION</u>	<u>TEST METHOD</u>
Dielectric Strength			
1 mil	7,000 v/mil	60 cycles	ASTM
2 mil	5,400 v/mil	¼" electrodes	D-149-61
3 mil	4,600 v/mil		
5 mil	3,600 v/mil		
Dielectric Constant			
1 mil	3.5	1 kilocycle	ASTM
2 mil	3.6		D-150-59T
3 mil	3.7		
5 mil	3.7		
Dissipation Factor			
1 mil	.0025	1 kilocycle	ASTM
2 mil	.0025		D-150-59T
3 mil	.0025		
5 mil	.0027		
Volume Resistivity			
1 mil	1 x 10 <sup>18</sup> ohm-cm	125 volts	ASTM
2 mil	8 x 10 <sup>17</sup> ohm-cm		D-257-61
3 mil	5 x 10 <sup>17</sup> ohm-cm		
5 mil	1 x 10 <sup>17</sup> ohm-cm		
Corona Threshold Voltage			
1 mil	465 volts	60 cycles	ASTM
2 mil	550 volts	¼" electrodes	1868-61T
3 mil	630 volts		
5 mil	800 volts		
5 mil H/2 mil FEP/ 5 mil H/½ mil varnish	1,600 volts		

5.6 Dielectric Strength. Typical values for the dielectric strength of Kapton H range from 7000 V/mil for a 1-mil film to 3600 V/mil for a 5-mil film, at 60 Hz, between 1/2-inch diameter electrodes in 23°C air at one atmosphere pressure for one minute. These dielectric strengths are based on the statistical average breakdown of carefully manufactured polyimide films having the indicated thickness. These values cannot be used in equipment design because:

- o Films vary in thickness within manufacturing tolerances.
- o The composition of Kapton-H varies.
- o The operating temperature will not be 23°C.
- o Voltage transients must be considered.
- o Field stress with other electrode shapes is different.
- o The end-of-life dielectric strength is lower.

A more complete definition of the dielectric strength of Kapton-H is provided in Figures 5.5.2A, 5.5.2B, and 5.5.2C. The effect of temperature on dielectric strength is shown in Figure 5.5.2A. In aerospace applications, the highest operating temperature for a unit is usually specified, for example as 80°C. This is not the insulation design value. The insulation design temperature must be that of the hottest point within the equipment. An electrically insulated heat-generating element will operate at a temperature which is sufficiently hotter than ambient to drive the generated heat through the insulation. For instance, the hot spot temperature near a silicon-controlled rectifier may be 20°C higher than the nominal temperature of the insulation. Such "hot spots" are created by high current densities in electronic devices and the heat generating mechanisms in the insulation itself. It is obvious from Figure 5.5.2A that an extra 20°C may lower the dielectric strength considerably when the insulation is either thin or operated at temperatures above 200°C.

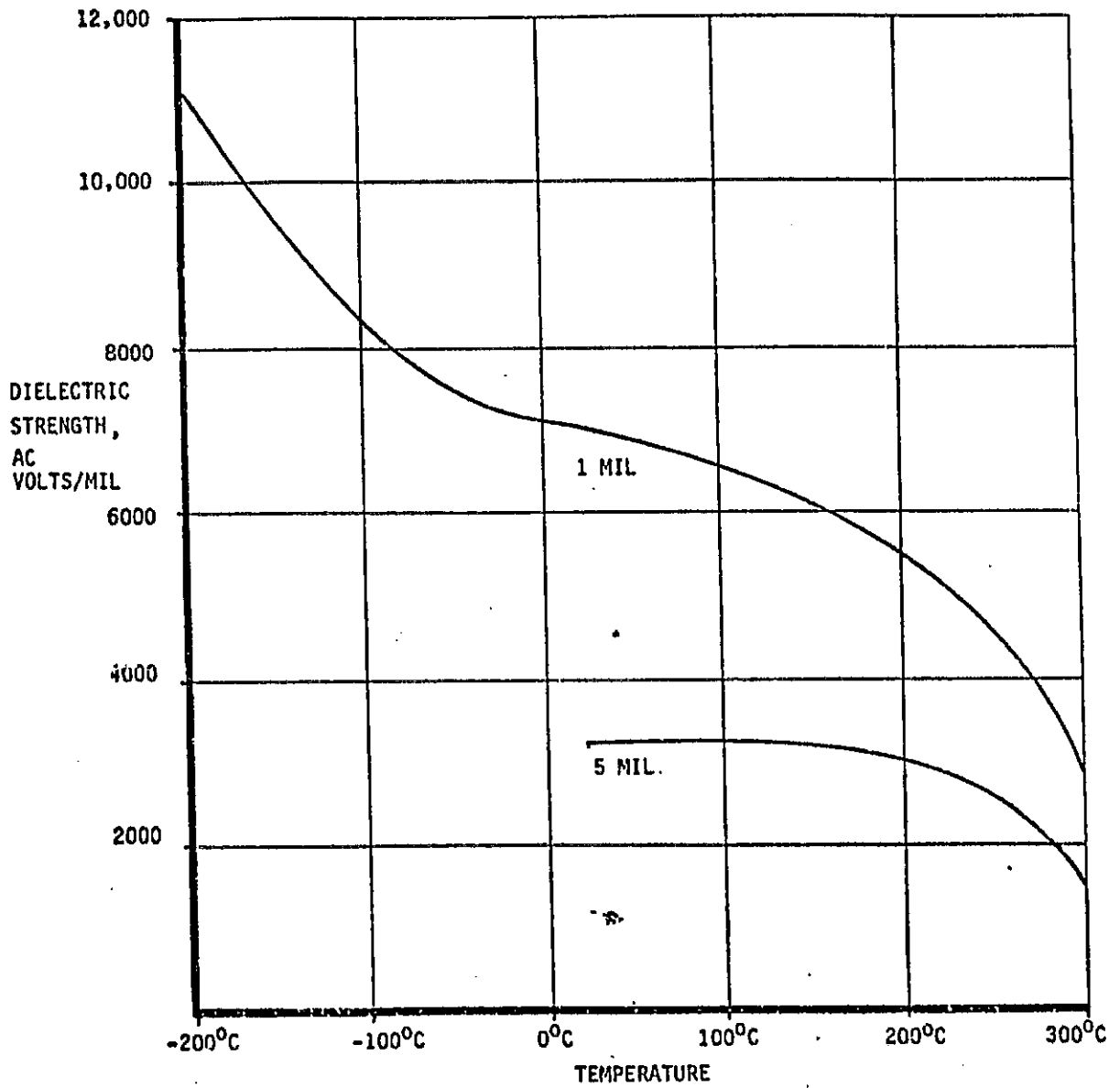

FIGURE 5.5.2A -TEMPERATURE AFFECTS AC DIELECTRIC STRENGTH TYPE H KAPTON FILM

Relative humidity also affects the dielectric strength of Type-H Kapton as shown in Figure 5.5.2B. For this reason, very high-voltage equipment is often packaged in sealed containers backfilled with a dry dielectric gas such as nitrogen during storage. Generally, insulation in dry gas has higher dielectric strength than in moist gas. Dielectric strength tests for spacecraft should be made at near 0% relative humidity.

Most insulation test samples are either 1 mil or 5 mils thick. In high voltage work, a thin insulation does not have high enough dielectric strength to meet the component voltage stress requirements, so thicker insulation must be used. It must be remembered that dielectric strength of insulation decreases with thickness, as shown in Figure 5.5.2C.

Total area of insulation is a factor often neglected in literature and data sheets. For areas of a few square centimeters, the effect is small, usually requiring less than 5% derating. For large areas, the required derating is considerable, as shown in Figure 5.5.2D. This loss of dielectric strength is caused by roughness of electrode surfaces and nonuniform thickness of the manufactured insulation.

All organic materials have lower dielectric strength at higher frequencies. The example in Figure 5.5.2E illustrates the magnitude of change.

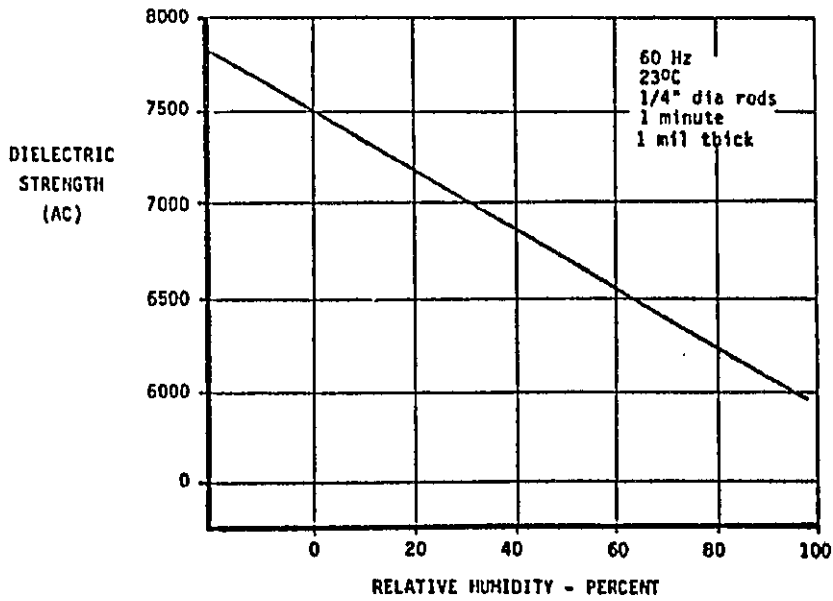

FIGURE 5.5.2B -HIGH HUMIDITY DEGRADES THE DIELECTRIC STRENGTH OF TYPE H KAPTON FILM

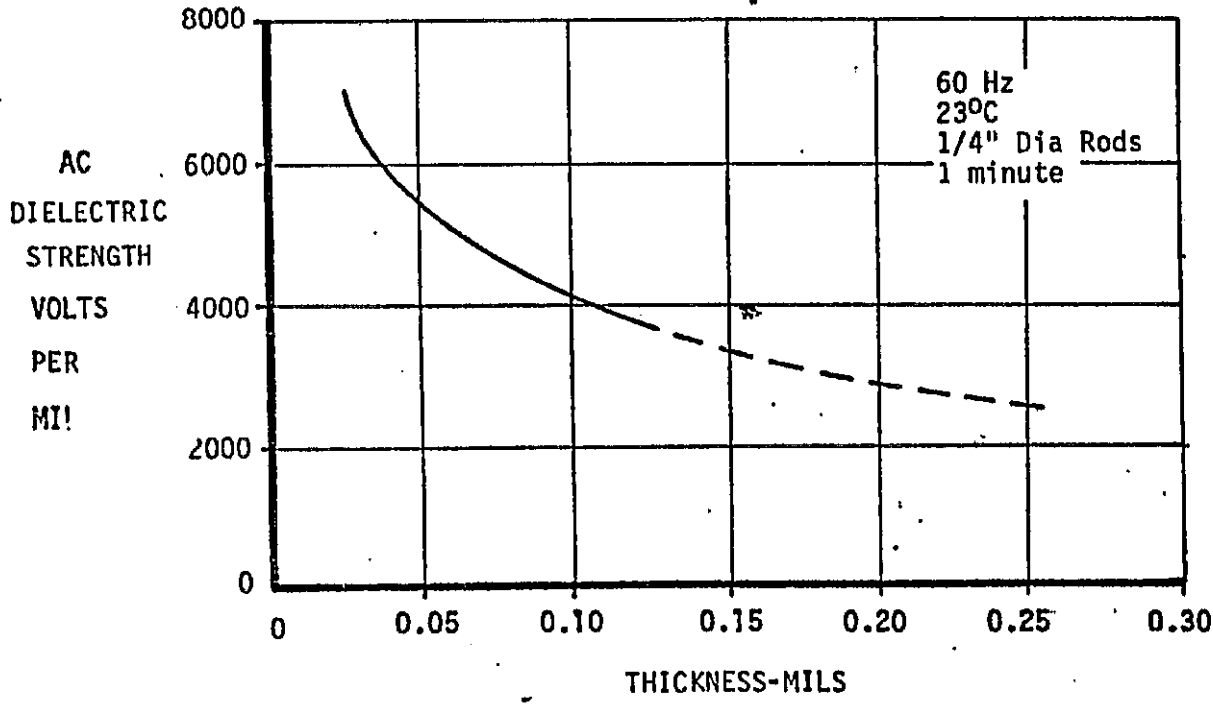

FIGURE 5.5.2C-INSULATION THICKNESS AFFECTS DIELECTRIC STRENGTH OF TYPE H KAPTON FILM

26D

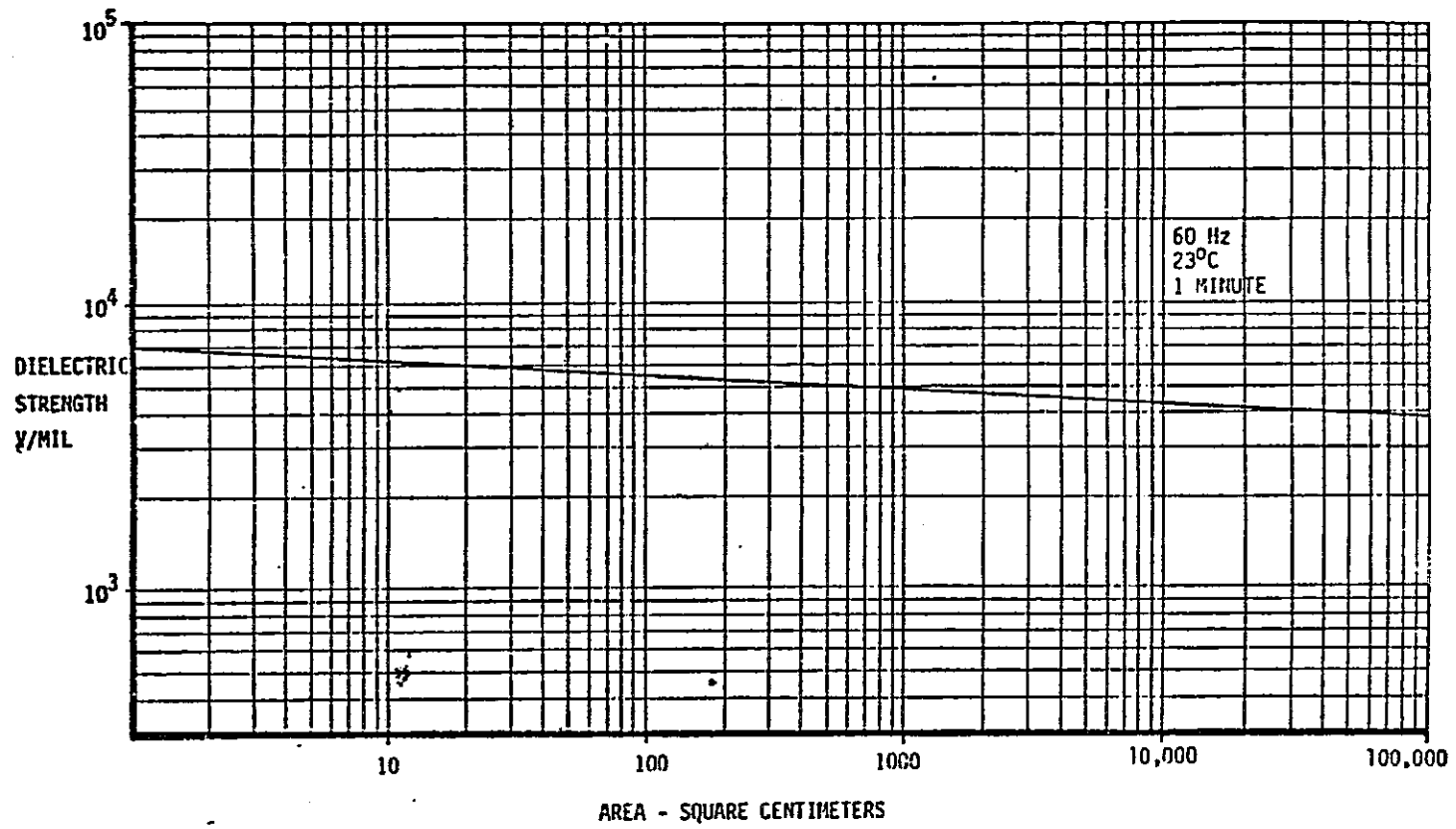

FIGURE 5.5.2D - FILM AREA VS DIELECTRIC STRENGTH OF TYPE H KAPTON

26D

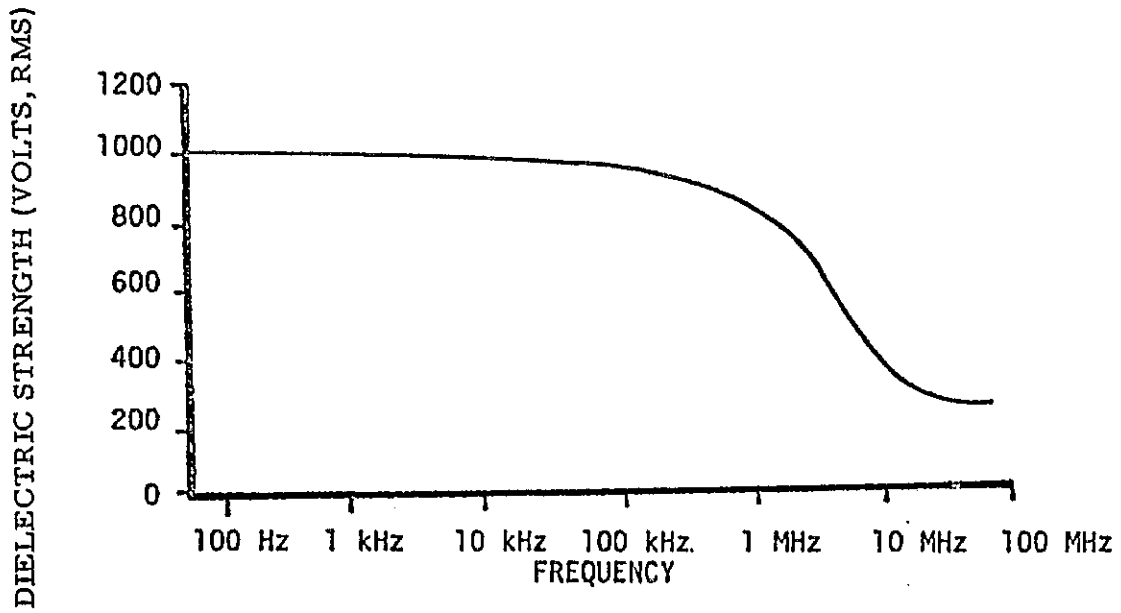

FIGURE 5.5.2E - EFFECT OF FREQUENCY ON DIELECTRIC STRENGTH



5.7 Insulation Life. Finally, the most important factor in high voltage insulation design is the life of the material. Each year many technical papers are published on the measurement of life factors, the deviations associated with the test data, and the preconditioning of test samples. All these significant factors must be considered. However, the designer often has difficulty in finding data other than from one minute tests at 23°C and 60 Hz between 1/2 inch diameter electrodes. Such tests tell little about the long-life characteristic of the material. The life of Type-H Kapton Polyimide is shown in Figure 5.5.2F for film exposed and not exposed to partial discharges. With the exposed samples, partial discharges were present whenever the initiation voltage of 465 volts was exceeded.

The characteristic life of a material can be evaluated as a function of temperature when available data are plotted as an Arrhenius plot with long life on the abscissa and the reciprocal of the absolute temperature on the ordinate (Figure 5.5.2G). Life as a function of temperature is determined by measuring the breakdown at 50 percent of the one-minute level. Data for the life-temperature plot is taken as follows: 1) numerous samples are kept at constant test temperatures, 2) periodically a few samples are withdrawn and their breakdown voltages are measured, 3) when the statistically developed breakdown voltage of the withdrawn samples is 50 percent of the initial one-minute breakdown voltage, the end-of-life is assumed to be reached for the specific sample and its temperature. The life test must be conducted at several temperatures; therefore, much testing is required to gain this important information.

Solid electrical insulation has many factors which alter its useful life characteristic. Some of the more important factors are: temperature, frequency, thickness, and field stress. How these variables effect the life of Kapton are shown in Figures 5.5.2A thru D. A typical design approach, using Kapton is as follows:

- a. First select the candidate insulation and then determine the maximum "hot spot" operating temperature on the material. The "hot spot" temperature is for steady-state temperature at normal voltage stress.

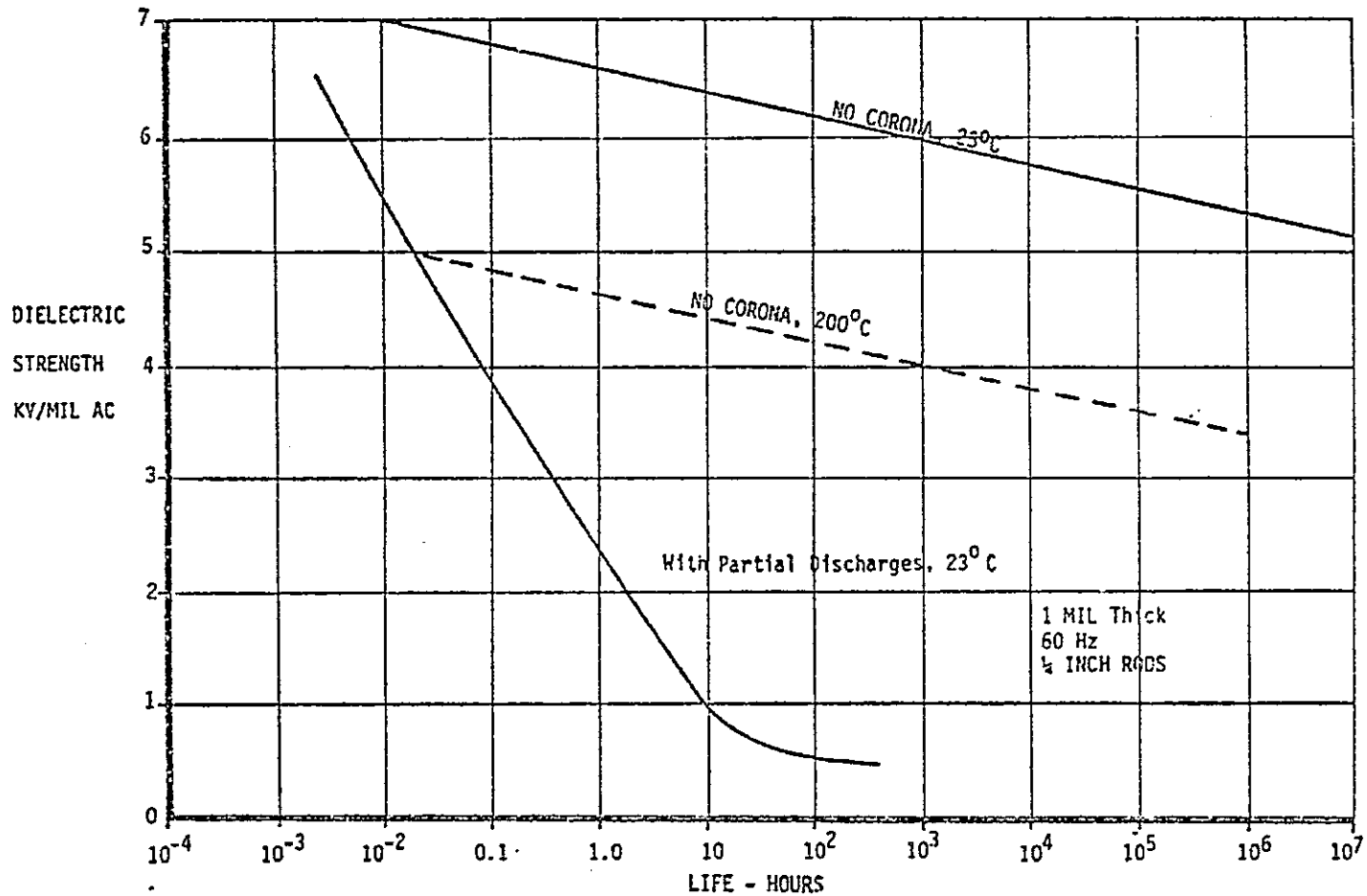

FIGURE 5.5.2F - LIFE AS A FUNCTION OF VOLTAGE FOR TYPE H KAPTON FILM

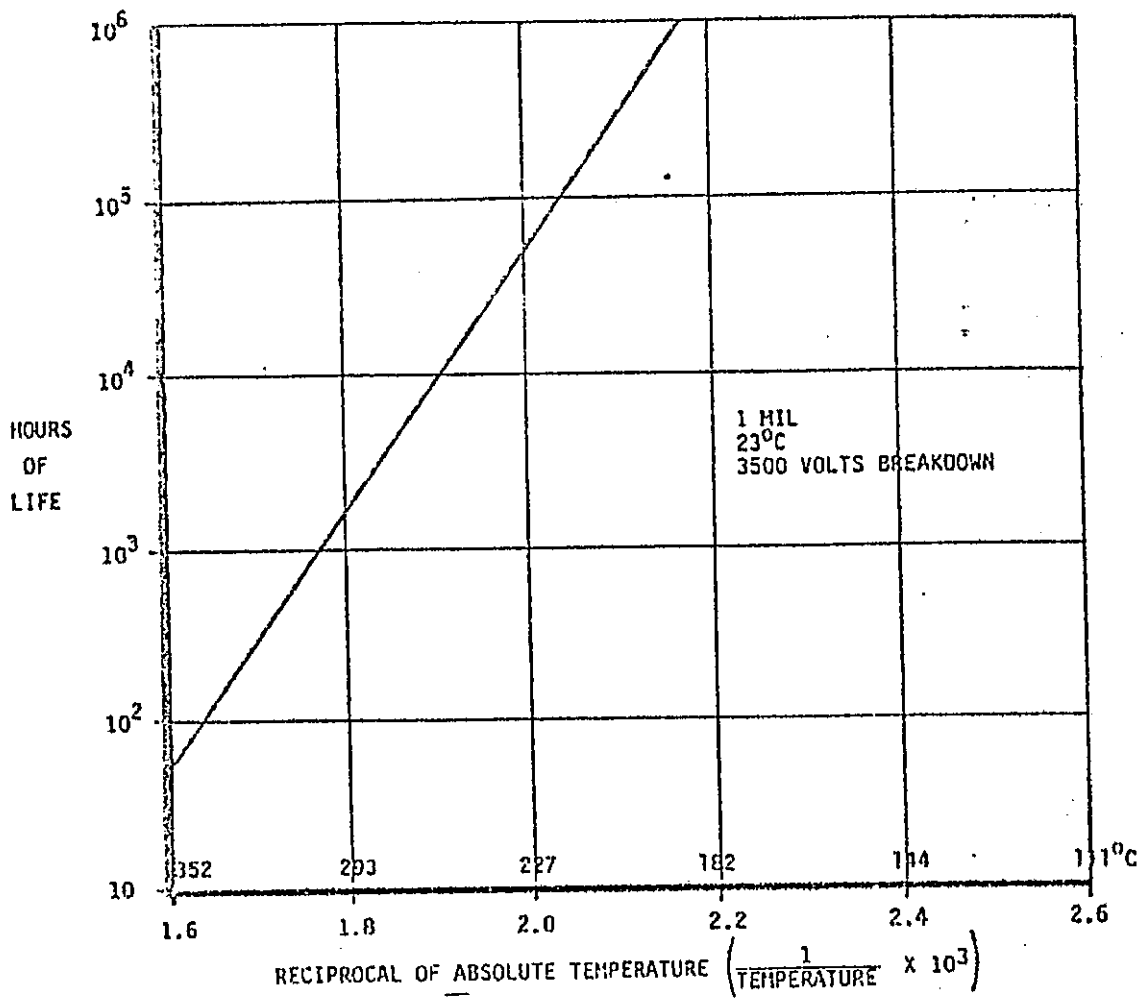

FIGURE 5.5.2G - HEAT REDUCES THE TIME FOR KAPTON TYPE H FILM TO FALL TO HALF OF ORIGINAL DIELECTRIC STRENGTH

- b. Determine if the operating "hot spot" has the highest electrical stress by making a field plot.
- c. Select the highest temperature as the operating temperature with the highest electrical field stress as the operating stress to determine the temperature derating factor from Figure 5.5.2B thus:

$$R_c = \% \text{ at } 23^\circ\text{C} = \frac{\text{Dielectric strength "hot spot"}}{\text{Dielectric strength at } 23^\circ\text{C}}$$

- d. Determine the operating frequency. If the package operates throughout at DC potentials use:

1.8 times the 60 Hz rating

If the package has ac and dc voltages choose the highest frequency and compare it with the 60 Hz rating from Figure 5.5.2D.

$$R_f = \% \text{ at } 60 \text{ Hz} = \frac{\text{Volts at operating Frequency}}{\text{Volts at } 60 \text{ Hz}}$$

- e. Determine the first choice thickness of insulation and compare that value with the 1 mil standard. Occasionally, an insulation's voltage rating will be based on a 0.125, 0.255 or even 1.25 millimeter thick sample. That value must be adjusted to the 1 mil standard as shown in Figure 5.5.2C. Then determine the thickness factor.

$$R_t = \% \text{ at } 0.025 \text{ mm (1 mil) operation} = \frac{\text{Volts at applied thickness}}{\text{Operating volts at } 0.025 \text{ mm (1 mil)}}$$

- f. The derating factor for the insulation can be determined. It is:

$$D = R_c \times R_f \times R_t$$

- g. This derating factor will be used to determine useful life. Life is based, in this example, upon operation at 23°C, 60 Hz and 0.025 mm (1 mil). From the life curve of Figure 5.5.2F determine the maximum operating voltage in volts per mm (mil),  $V_m$ . The operating voltage,  $V_o$ , is:

$$V_o = V_m D$$

This is the maximum allowable operating voltage at the maximum stress point for the selected life.

5.8 Field Gradients - Probably the most effective method for determining the electrical stress in an electrical insulation is to plot or calculate the electrical field. Each conducting configuration has an unique field. These fields can be between conductors, a conductor and a ground plane, or a combination of the two. Some typical field plots are shown in Figures 5.6.1, 5.6.2, 5.6.3 and 5.6.4. The classical field plots are shown in Figure 5.6.1 for the field around two points in space. A field plot applicable to an insulated conductor on a printed circuit board is shown in Figures 5.6.2 and 5.6.3. In Figure 5.6.3 both the short field lines and long field lines have significance. The region at the very narrow space between the insulation and ground plane location "A" will have minimum corona onset at 6.6 to 12.5 N/m<sup>2</sup> for insulation thicknesses between 0.25 and 1.25 mm. The long spacings at region "B" which may be as long as 20 centimeters, will have minimum corona onset at pressures as low as 0.1 N/m<sup>2</sup>. This variance in the COV pressure characteristics is attributed to the Paschen Law of the gaseous media. Since the minimum breakdown is constant at a given pressure times spacing, the pressure must decrease for the wide spacings to increase the COV. Parallel conductors and an elbow bend are shown in Figure 5.6.3 as further examples of field plotting.

Many elementary and analytical physics and engineering text books have excellent field plots and describe their analysis and sketching. Field plotting is tedious work and requires much analysis. Therefore, it is often more expedient to calculate the field stress, especially when the stress next to a curved surface is required. To do this, use of the exact mathematical formulas may take as long as the field plot. Therefore, some approximate algebraic formulas are given in Figure 5.6.5. These formulas have excessive errors for spacings greater than 10 centimeters and very sharp radii of less than 0.1 millimeter such as that encountered on a screw thread. They are applicable to conductors, printed circuit board geometric conductors and most standard components. The COV for the configurations of Figure 5.6.5 can be varied by using a pressurizing gas other than air.

5.9 Voltage Distribution in Gas-Solid Dielectrics - The corona onset voltage in solids is many times higher than in gases. Also, in solids, as in gases, the start of repetitive ionization is the beginning of dielectric breakdown, and solid insulations generally have much greater dielectric strength than gaseous insulations. Thus, corona should occur first in the gas surrounding a homogeneous solid dielectric. The corona onset voltage in gases can be determined by using established curves for various gap dis-

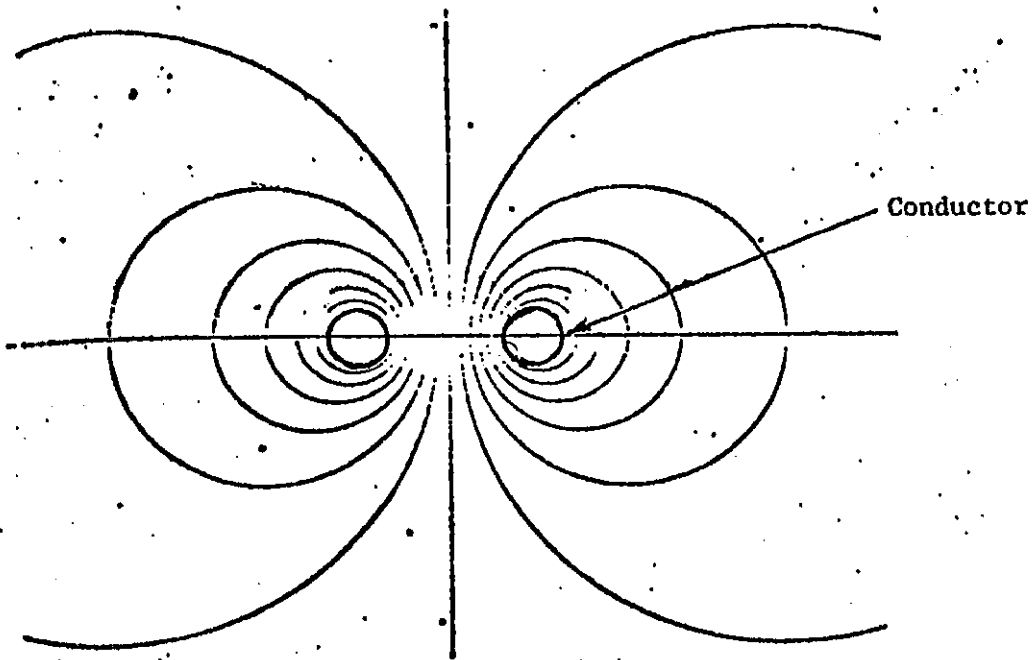

(A) EQUIPOTENTIAL SURFACES

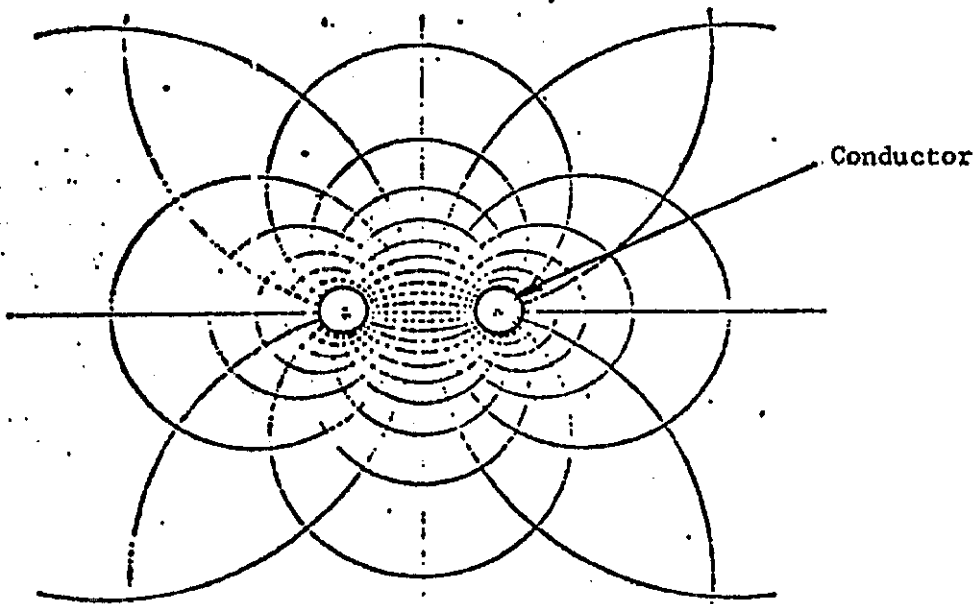

(B) DIRECTIONAL FIELD LINES

FIGURE 5.6.1 EQUIPOTENTIAL SURFACES AND DIRECTIONAL LINES FOR EQUAL, OPPOSITE, AND INFINITELY LONG CONDUCTORS

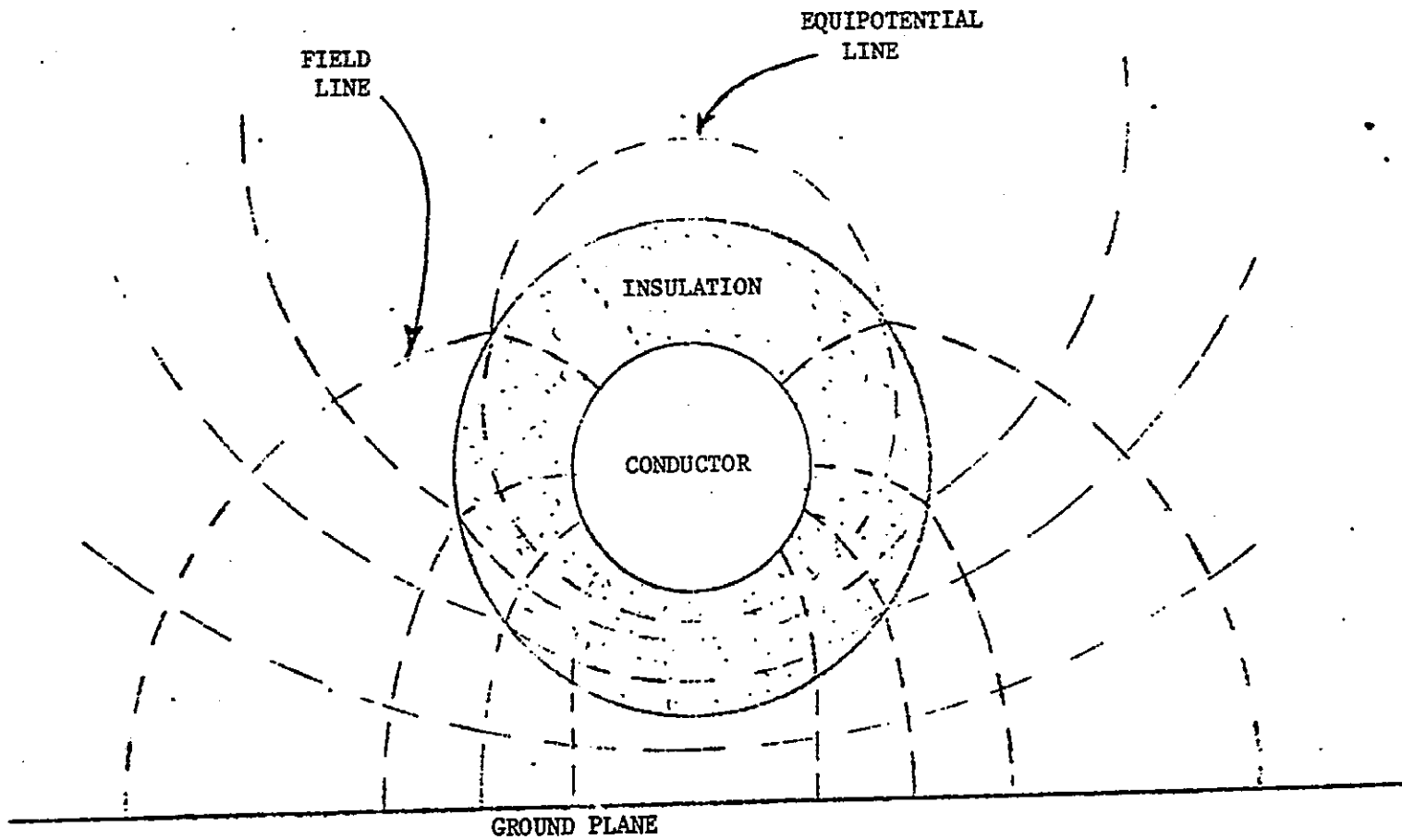

FIGURE 5.6.2 TYPICAL FIELD PLOT OF CONDUCTORS SHOWING CURVILINEAR SQUARES FROM INTERSECTING EQUIPOTENTIAL AND FIELD LINES

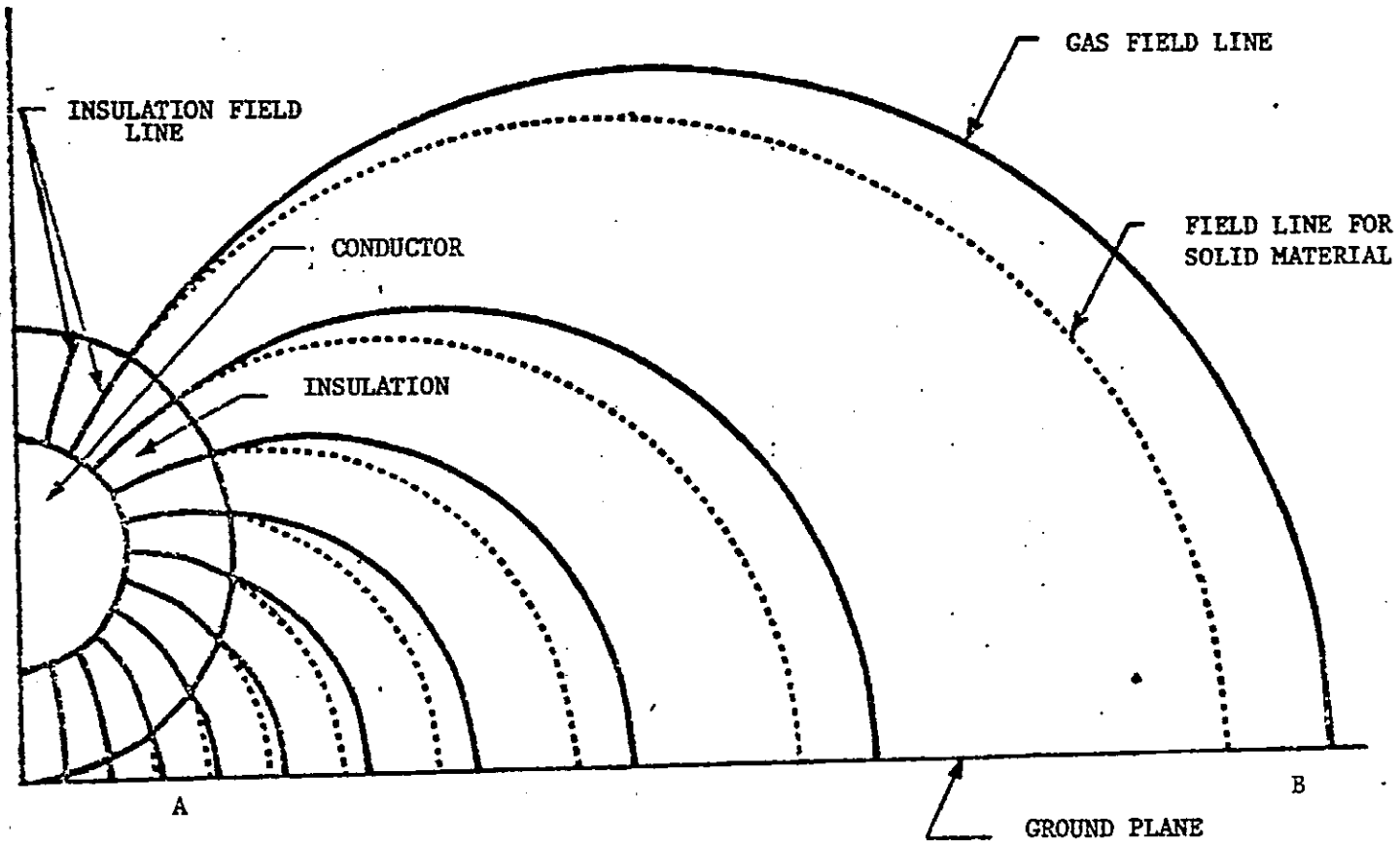
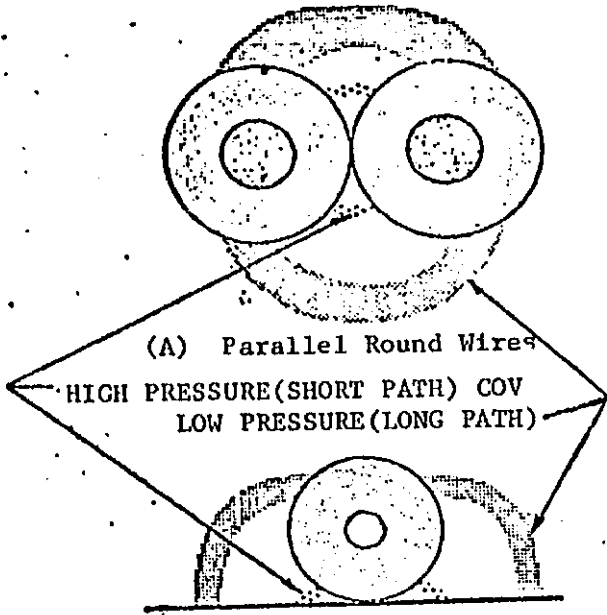
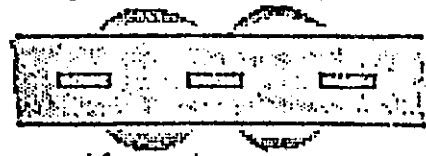

FIGURE 5.6.3 ELECTRIC FIELD LINES SHOWING THE EFFECT OF INTERELECTRODE MEDIUM ON THE SHAPE OF THE PLOTTED FIELD





(B) Round Wire to Ground Plane



(C) Flat Cable Configuration



(D) Flat Cable to Ground Plane

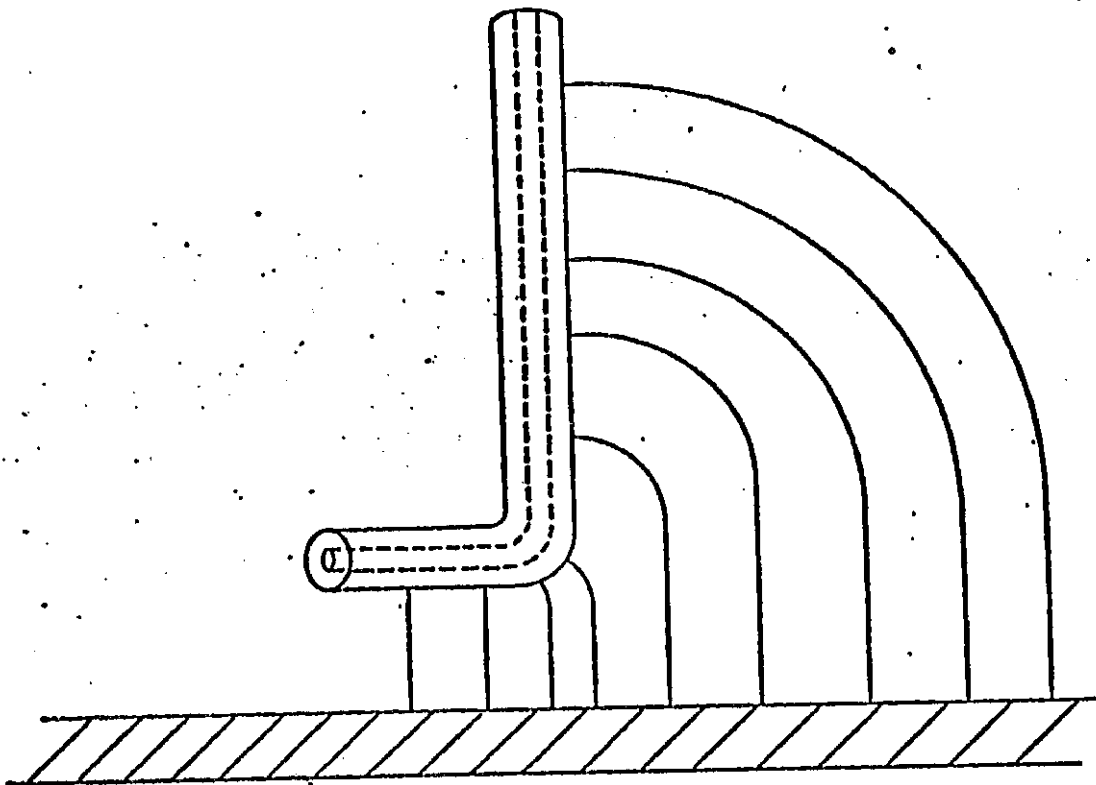

(E) Right Angle Bend Conductor to Ground Plane

FIGURE 5.6.4 ELECTRIC FIELD LINES BETWEEN CONDUCTORS AND FROM CONDUCTOR TO GROUNDPLATE FOR TYPICAL CONDUCTORS

Configuration

Maximum Voltage Stress

Corona Onset Voltage

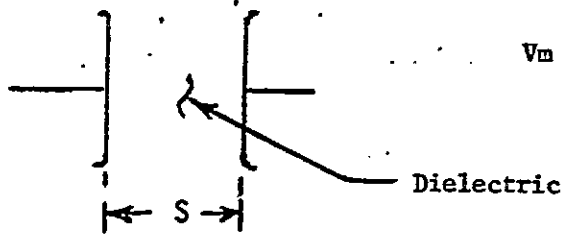

$$V_m = \frac{V \text{ applied}}{S}$$

Depends on electrode radius of curvature and edge effects.

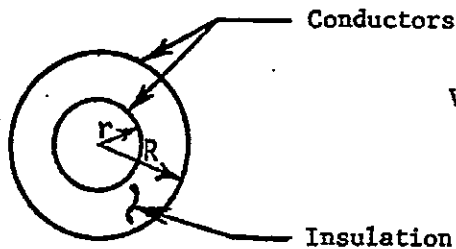

$$V_m = \frac{V \text{ applied}}{r \log \frac{R}{r}}$$

$$\frac{R}{r} < 2.718$$

34

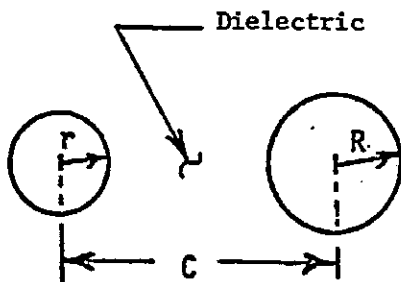

$$V_m = \frac{V \text{ applied} \left[ \frac{R^2 - r^2 + C^2 + 2rC}{R^2 - r^2 + C^2 - 2rC} \right]^{1/2}}{r \log \left[ \frac{C^2 - (R-r)^2 + m}{C^2 - (R-r)^2 - m} \right]}$$

$$\frac{C}{r} < 5.85$$

$$m = (C^2 - r^2 - R^2)^2 - 4r^2 R^2$$

FIGURE 5.6.5 CORONA AND MAXIMUM VOLTAGE STRESS FORMULAS

tances and electrode configurations. The remaining problem is one of establishing how the applied voltage distributes itself between the gas and solid portions of the dielectric path.

It can be shown that when a voltage is applied to two capacitors in series, the applied voltage,  $V$ , will be divided between the two capacitors by:

$$V = V_1 + V_2 \quad \text{Eq. 5.7.1}$$

where  $V$  = voltage across the two capacitors

$V_1$  = voltage across the solid dielectric capacitor

$V_2$  = voltage across the gas dielectric capacitor

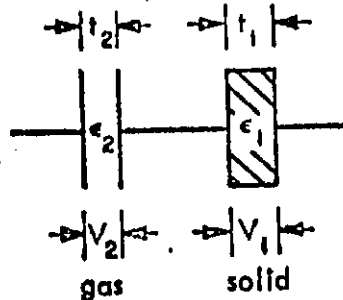

Figure 5.7.1 Two Capacitors in Series

If one of the capacitors is gas filled as shown in Figure 5.7.1 then, the dielectric constant of the gas-dielectric capacitor is 1.0 which is the approximate dielectric constant of most gases.

Then calculations can be made to derive  $V_2$ , the voltage across the gas capacitor, which becomes:

$$V_2 = \left[ \frac{V}{\frac{t_1}{t_2 \epsilon_1} + 1} \right] \quad \text{Eq. 5.7.2}$$

where:  $t_1$  = thickness of the solid dielectric (cm)

$t_2$  = distance across the gas dielectric (cm)

$\epsilon_2 \epsilon_1$  = dielectric constant of the gas and solid

Measurements show that the breakdown voltage in a gas dielectric uniform field is the same as the corona onset voltage. Substituting the corona onset voltage,  $V_{CS}$ , for  $V_2$  in equations 5.7.1 and 5.7.2 then gives limiting voltage for corona-free operation.

$$V = V_{CS} \left[ 1 + \frac{t_1}{t_2 \epsilon_1} \right] \quad \text{Eq. 5.7.3}$$

Similarly, an equation can be derived for two solid dielectrics in series with one air gap as shown in Figure 5.7.2.

$$V = V_{CS} \left[ \frac{t_1}{t_2 \epsilon_1} + 1 + \frac{t_3}{\epsilon_3 t_1} \right] \quad \text{Eq. 5.7.4}$$

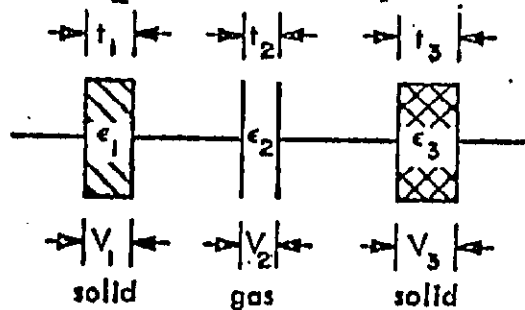

Figure 5.7.2 A Gas Filled Dielectric in Series With Two Solid Dielectrics

where:  $\epsilon_3$  = dielectric constant of the second solid dielectric  
 $t_3$  = thickness of the second solid dielectric

A condition sometimes encountered in practice is two gas gaps in series with a single solid dielectric as shown in Figure 5.7.3. The applicable equation is:

$$V = V_{CS} \left[ \frac{t_1}{t_4 \epsilon_1} - \frac{t_2}{t_4} + 1 \right] \quad \text{Eq. 5.7.5}$$

and in the case where the air-gap thicknesses are equal:

$$V = V_{CS} \left[ \frac{t_1}{t_4 \epsilon_1} + 2 \right] \quad \text{Eq. 5.7.6}$$

where:  $t_4$  = thickness of second gas gap.

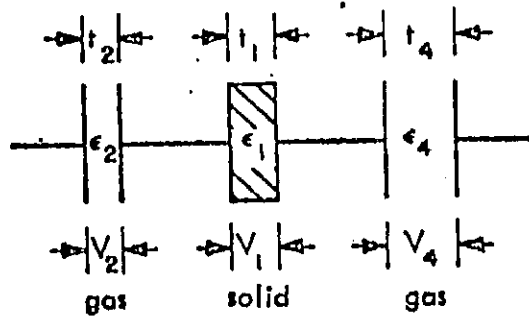

Figure 5.7.3 A Solid Dielectric in Series With Two Gaseous Dielectrics

The voltage applied to two insulated wires will divide into three components: the voltage across each of the two wire insulations, and the voltage across the space between the insulations. This voltage distribution is unlike that encountered in series capacitors where the voltage across the air capacitor is proportional to the voltage across the solid-insulation capacitor for all applied voltages. With parallel wires, the thickness of the insulation is constant around the wire, but the thickness of the gap between wires varies from a minimum in the space between the wires to a maximum from the far side of one conductor to the far side of the other conductor. This results in a nonlinear electric field shown in Figure 5.6.3.A.

## 6. DESIGN APPLICATIONS

A good design will ensure that the voltage gradient to which the electrical insulation is subjected always leaves a design margin within the insulation. The preceding section on High Voltage Design gave some of the electrical parameters and analytic criteria for applying gaseous and solid insulation to a high voltage network. This section is devoted to some design applications which have attributed to the successful operation of high voltage circuitry in space.

6.1 Solid Insulation - The necessity for encapsulation has been raised at Symposiums on spacecraft electrical high voltage systems. For the purpose of the following discussion, encapsulation (potting) and conformal coating will be defined as follows: conformal coating is the application of three or more individual coats of low viscosity liquid insulation to a circuit or printed circuit board in which each coat is cured resulting in a solid coating which is free of a continuous path through the layers on all components and wires. Encapsulation (potting) is the immersion of all electrical components, circuits, and printed circuit boards into a liquid insulation which when cured is a void-free solid insulation.

### 6.1.1 High Voltage Conformal Coating

- a. Most printed circuit boards for space flight hardware, regardless of voltage, require some insulation. The circuit boards should be conformally coated with at least 3 separate layers of a low viscosity insulation. Application may be either by dipping or spraying with each layer applied at right angles to the preceding layer. The three layers are recommended to eliminate the pinholes (continuous leakage path) and uncoated areas that normally occur in single or double coating processes. The completed process should be checked by an insulation test. Conformal coating should be in accordance with MSFC-PROC-508.
- b. All boards, conductors, wiring, and electrical components must be cleaned per the appropriate specification before the unit is conformally coated. This includes solder flux, finger prints, and particles from the work bench and dust.
- c. The final step in an electrical assembly is the wiring and soldering of the printed circuit board assembly. The wire and solder joints must be cleaned and conformally coated with the same precaution as the electrical networks on the printed circuit boards.

6.1.2 Encapsulation - An adequately encapsulated high voltage circuit has all the interspace between electrical components, wires, circuit boards and ground planes filled with a homogenous solid insulation. This process must have the following qualities:

- a. All components, boards, and wiring must be cleaned of particles, grease, finger prints, non-cohesive materials, and solder flux prior to encapsulation.
- b. The materials must be checked for bonding to the components by laboratory testing. The tests should include: temperature cycling, high voltage stress during temperature cycling, and shelf life storage prior to temperature cycling. A common error is to evaluate a material in a soft flexible aluminum dish and then expect it to hold its properties in a solid structural application.
- c. The encapsulated volume should be kept small without jeopardizing the electrical integrity of the encapsulant. When large volumes are required, the volume should be long and narrow. This reduces the probability of internal mechanical stresses which can result in component-to-component cracks. Volumes with physical dimensions greater than one inch wide and two inches deep, and several inches long may have many internal cracks.
- d. Solid encapsulation must be void-free to be effective. This especially includes voids near the ground plane as well as the high voltage components and circuits. Three methods of void-free encapsulation are vacuum impregnation, centrifugal acceleration, or a combination of those two.
- e. Final encapsulation of high voltage interconnecting wiring and terminal parts must be done very carefully. The wires must be properly fixtured so they are not pulled or twisted or otherwise disturbed during or following the proper cure.

The encapsulant must bond to all the other materials. This is especially true of like materials. Sometimes a poor bond can exist between a newly applied insulation and an insulation of the same type which has been oxidized or has shelf degradation.

6.1.3 Uninsulated Circuitry - Uninsulated circuitry is not recommended for the following reasons:

- a. Materials migration is enhanced across open faced circuit boards.
- b. Particles from space and the spacecraft can accumulate on the circuit board and lead to the Malter effect, i.e. momentary short circuits as in a precipitator. In "zero-g" orbital condition, floating debris may short out two adjacent circuits or reduce the effective distance between them, so that corona, tracking, or flashover may occur.
- c. Surface flashover is enhanced.
- d. Some bare metallic surfaces when oxidized, have lower corona and breakdown voltage than a coated or encapsulated surface.

6.2 Wiring - Once the pressure surrounding a high voltage power unit or circuit has been established, the pressure around critical components and any transient pressure pulses near high voltage circuits must be determined. Some of these pressures are considerably higher than the average vacuum atmosphere in the spacecraft. A high voltage lead can be used to demonstrate the pressure differentials that may exist. When the lead is soldered at each end, conformally coated or encapsulated, and permitted to stand for 3 to 6 months at room pressure, the inside and outside pressure becomes stabilized. The entrapped air within the strands of the wire and between the strands and the insulated braid can create problems during a space mission. Figure 6.2.1 is an example of the terminal, wire connections, and all parts of the wire that are coated with a conformal insulation. This conformal insulation seals the wire ends and all the normal outgassing ports along the length of the wire. Therefore, a pressure differential of  $1 \times 10^5 \text{ N/m}^2$  (760 torr) will exist between the braid and outer jacket when the wire is subjected to space vacuum if it wasn't previously evacuated. In vacuum the outer jacket can be forced to expand at the weakest point by the internal pressure as shown in Figure 6.2.2. Heat and mechanical stress eventually create a small rupture in the jacket. At that time, the pressure is again equalized as the braid outgasses. This gas will create a transient pressure in the vicinity of the rupture. Any high voltage circuits in line with the rupture will be momentarily pressurized so that corona or voltage breakdown may occur. However, the rupture is most apt to occur near terminals, where the outgassing can create the greatest problem. After the braid



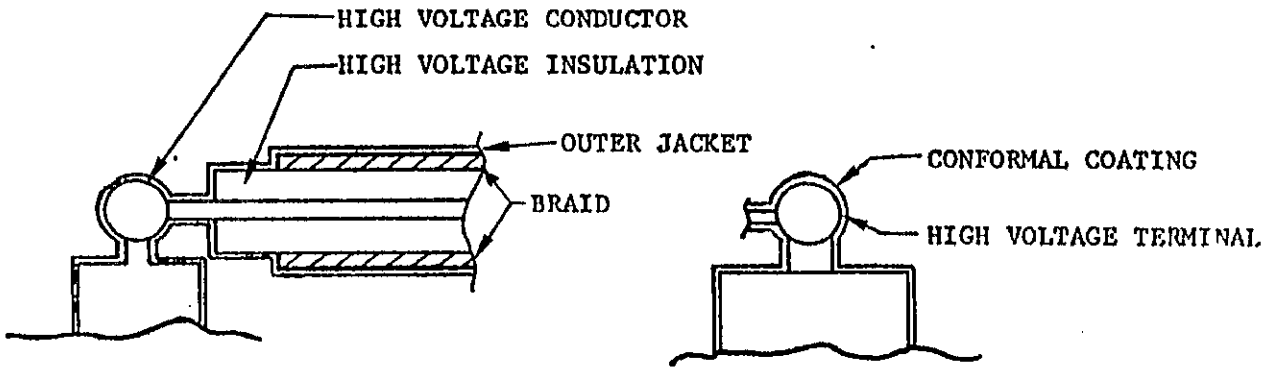

FIGURE 6.2.1 HIGH VOLTAGE CONDUCTOR AT ONE ATMOSPHERE

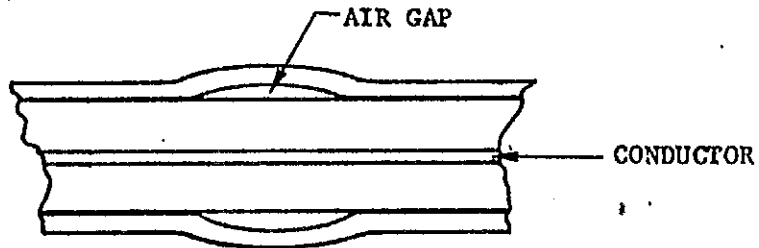

FIGURE 6.2.2 OUTER JACKET RUPTURE

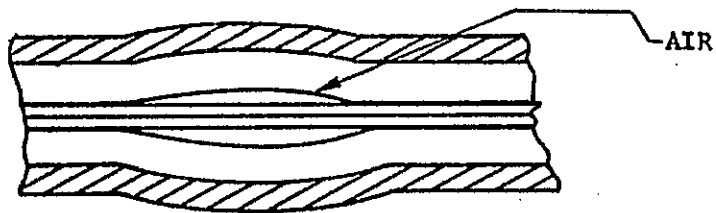

FIGURE 6.2.3 CENTER CONDUCTOR DELAMINATION

has outgassed, a pressure differential may exist between the braid and the conductor. Catastrophic failure may be averted if the braid and outer jacket exert enough pressure to prevent delamination of the insulation from the conductor. The existence and cause of flaws in the jacket materials must be investigated and a deliberate attempt made to eliminate them.

Flaws can be aggravated by two basic methods; abrasion and flexure. If the jacket material were scarred prior to installation, it would be thinner and could be expanded more easily than the unscarred material along the length of wire. A more probable cause is flexure. If the wire is bent, twisted or flexed several times during installation or during the testing and handling prior to high voltage system installation in the spacecraft, it is subject to breakdown by flexing. Each time flexing occurs along a specific portion of the wire, the stressing tends to weaken the insulation bonds to the conductors with subsequent weakening of the insulation. If the bond is weakened the insulation can pull away from the conductor as shown in Figure 6.2.3. Any separation results in a small air gap between the high voltage conductor and grounded braid via the high voltage insulation. Corona can be initiated in this void as the gas, if present, slowly leaks out into the vacuum of space, due to the reduced dielectric strength of the residual gas in the void. If the corona discharge persists for over 100 hours, the wire insulation will start to tree and eventually a short circuit will result.

Outgassing from unsealed wire strands will most likely be through the wire terminations. This outgassing can cause a momentary corona or voltage breakdown at the termination which can create an electromagnetic interference in the readout data. This corona impulse data, though erroneous, may be difficult to differentiate from the valid data.

Wire outgassing is one of the more difficult tasks for the insulation applications designer. If an outgassing port is made through the conformal coating to the center conductor, the wire may outgas for as long as 100 hours. A large port should be added so that a high field potential is eliminated between the braid and the conductor. A practical method is shown in Figure 6.2.4. The angle of the port ( $\alpha$ ) must be as nearly perpendicular to the field lines as possible. Any angle ( $\alpha$ ) greater than  $30^\circ$  may lead to tracking or flashover.

Solid wiring requires less venting than stranded wiring. Solid wire is recommended for use when flexing is not a requirement. When stranded wiring is required, the amount of flexing and stressing

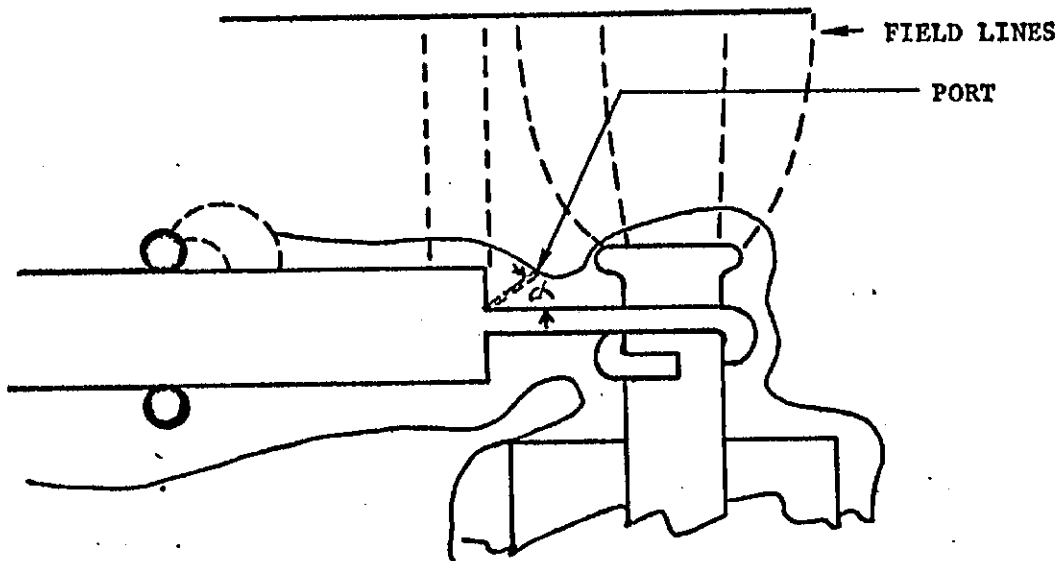

FIGURE 6.2.4 VENTED HIGH VOLTAGE WIRE

must be minimized. Any high voltage wire used with a power supply or high voltage hardware should be coiled around the power supply case and taped in place until it is required for test or connection. Precaution should be taken to prevent overstressing the wire by pulling or use of small radius bends. A sufficient length of high voltage wire should be available so the section to be connected is not required to be abnormally flexed or twisted during test.

**6.3 Packaging Encapsulation** - Solid encapsulation of components and circuitry are required for circuits with operating voltages over 1000 volts, peak, which operate in, or are subjected to, pressures between  $3.33 \times 10^4 \text{ N/m}^2$  (250 torr) and  $0.133 \text{ N/m}^2$  ( $1 \times 10^{-3}$  torr). Insulating materials, capable of long life terrestrial operation, may fail shortly after voltage is applied in a space environment. Other materials have outgassing products detrimental to nearby scientific instruments. Some materials may be selected from the applicable NASA spacecraft materials handbooks but all the materials should be approved by the available spacecraft high voltage insulation specialist. Some design features for the encapsulated circuitry are shown in Figures 6.3.1 and 6.3.2. The encapsulated portions may be divided into several sections to improve the electromagnetic compatibility. When several sections are used, feedthroughs and interconnections must be carefully designed to avoid carbon tracking and flash-over on the feedthrough, wiring and terminations.

A segmented package is shown in Figure 6.3.3. There are several significant design features shown in this type packaging.

- a. The ground planes are conformally coated. This decreases the probability of metal deposition on the encapsulating insulation from the ground plane. Considerable noise is generated when metal is being deposited.
- b. The air gap between the conformal coating and the encapsulated unit must be at least one millimeter wide to allow for outgassing.
- c. An outgassing port must be made for each compartment. This port must lead to a known vacuum environment. The vacuum on the outside must be less than  $1.33 \times 10^{-3} \text{ N/m}^2$  ( $1 \times 10^{-5}$  torr).
- d. The encapsulated components must be structurally stable. Where vibration will cause capacitance changes to ground (which can disrupt the circuit output) the component must be specially mounted to minimize movement.

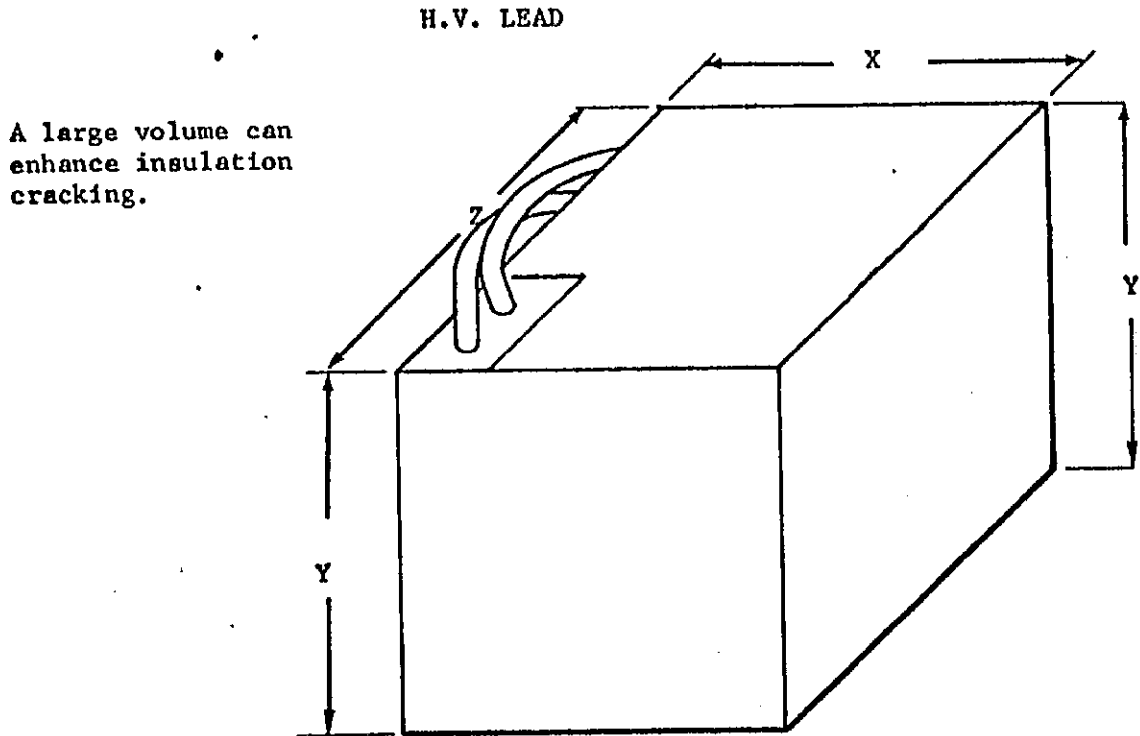

FIGURE 6.3.1 UNDESIRABLE ENCAPSULATION VOLUME

Several small volumes have better insulation integrity.

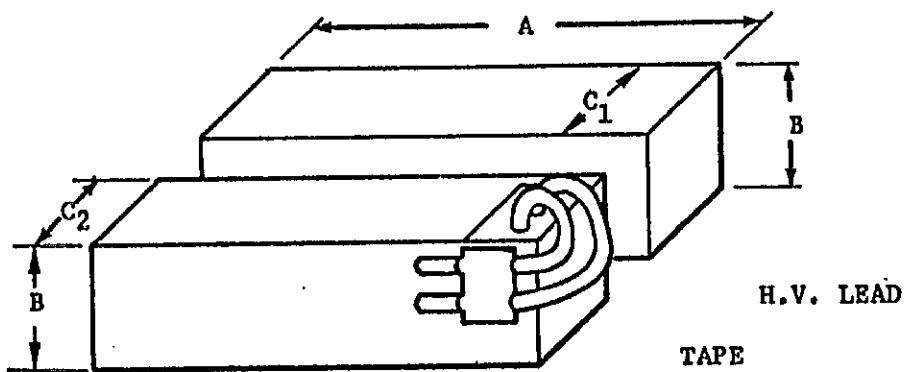
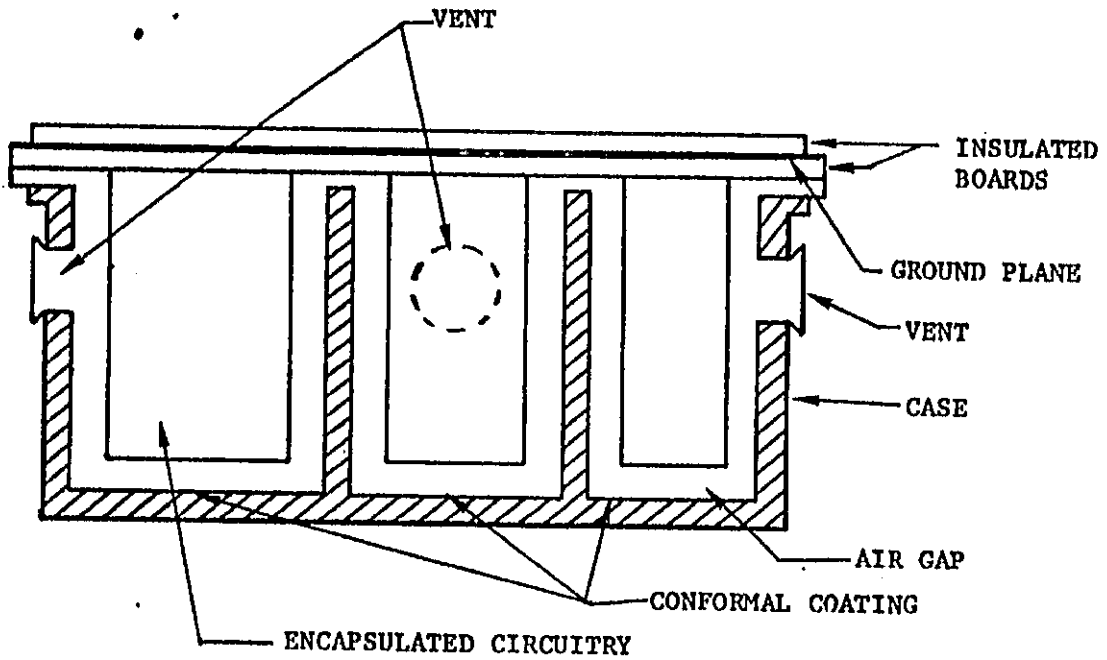

FIGURE 6.3.2 DESIRABLE ENCAPSULATION VOLUME

Note: Package "B" may be sectionalized further to enhance filtering.



Note: This packaging concept has operated to 8000 volts DC.

FIGURE 6.3.3 REMOVABLE ENCAPSULATED PACKAGING

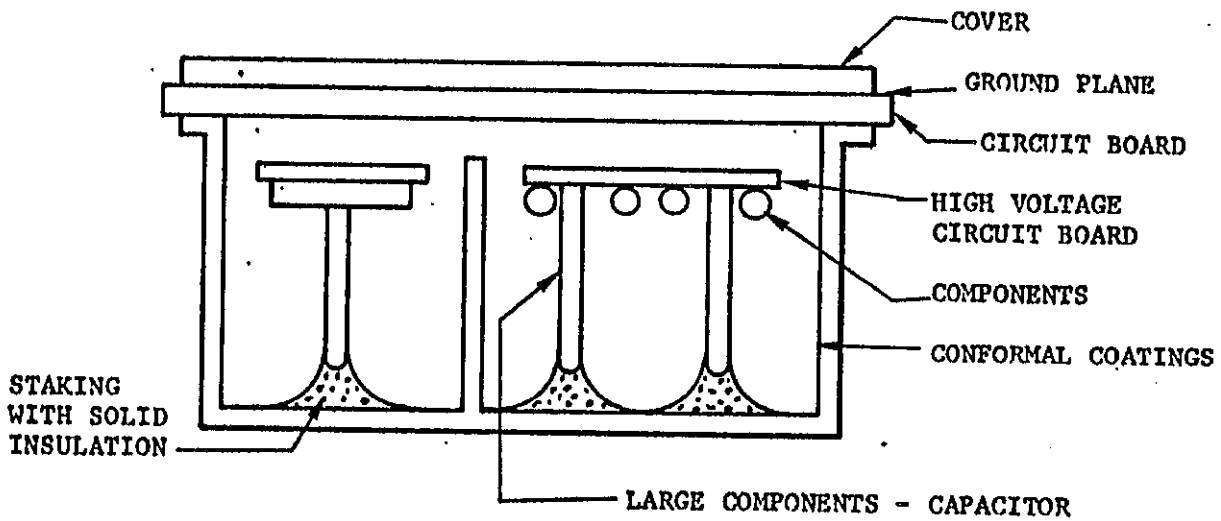

FIGURE 6.3.4 OPEN CONSTRUCTION PACKAGING

- e. A ground plane between the two circuit boards is added for electromagnetic shielding.
- f. The ground plane must be covered with an insulating board. The thickness of the board must keep the voltage stress below 2000 volts per mm based on a linear voltage stress.

Another packaging concept using open construction is shown in Figure 6.3.4. This type package has a limited amount of encapsulating materials and requires either vacuum or pressurization. All surfaces must be conformally coated and the capacitor or other large component staking must be done with vacuum impregnated encapsulants.

**6.4 Components** - Components must be evaluated in a space environment prior to acceptance as space qualified components. Some components such as resistors and capacitors were tested for corona and voltage breakdown in oil. This is not an acceptable test for space hardware. It is the responsibility of the designers and applications engineers to be informed of the test conditions and method used by the manufacturer before selecting and qualifying components for high voltage space applications. A few components will be critiqued in this section.

**6.4.1 Resistors** - Some resistors are constructed similar to the design shown in Figure 6.4.1.1. This design is acceptable only if the gas voids are filled with a solid insulation. In this design there is a large voltage gradient across the air gaps. When the gas leaks out, the low pressure gas ionizes and corona impulses are radiated into the circuit. In time, the insulating coating will fail and an arc will form. An acceptable design is shown in Figure 6.4.1.2. This resistor has a conformal coating over all its inner and outer surfaces. Only the terminations are bare. The terminations will be coated or encapsulated on the circuit board.

**6.4.2 Connectors** - Connectors may be rated for several thousand volts for aircraft and terrestrial designs and then fail at 1000 volts in space. This is caused by the air gaps that exist around the pins and sockets and across the insulation interfaces. Two typical connector constructions are shown in Figure 6.4.2.1 for round and flat wire connectors. These configurations are unacceptable for high voltage space applications. When potted, gas is

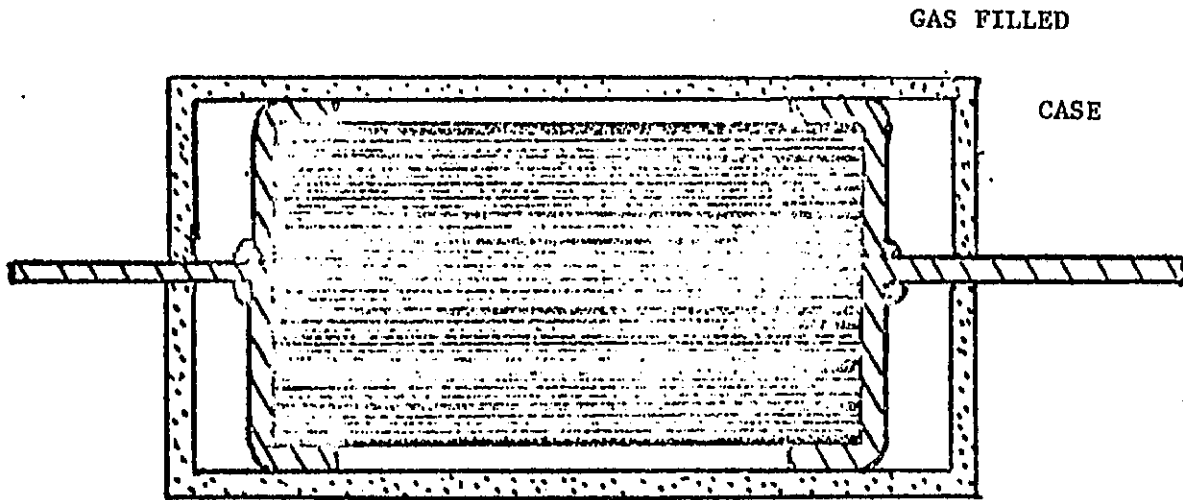

FIGURE 6.4.1.1 HIGH RELIABILITY RESISTOR

- Note: 1) Unacceptable for space with gas voids.  
 2) Acceptable for space when the gas voids are filled with a solid insulation.

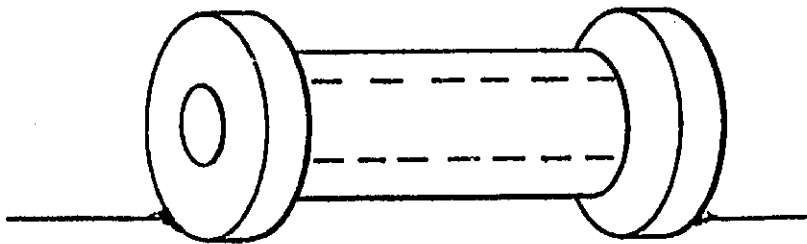
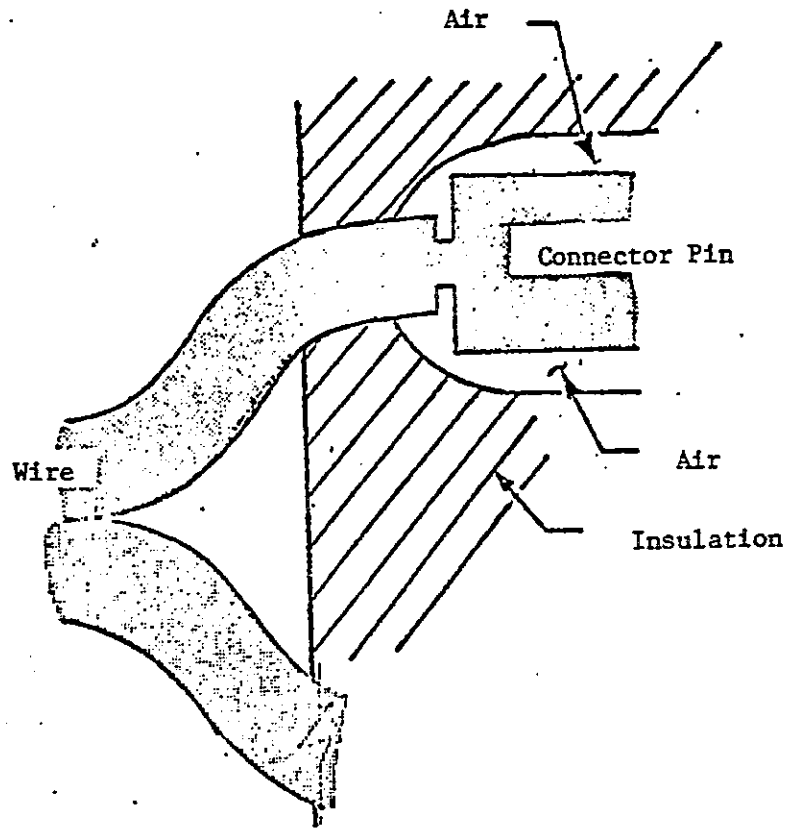

FIGURE 6.4.1.2 SPACE QUALIFIED RESISTOR





Round Wire Connector

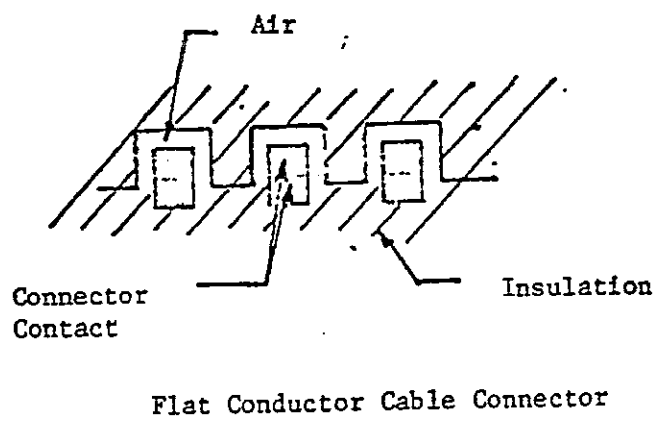

FIGURE 6.4.2.1 AIR IN CONNECTORS

entrapped and corona conditions can exist for many hours or days. In addition, the wire will outgas into the connector socket and pin ports and keep the connector pressurized. A high voltage connector concept with gas pockets is shown in Figure 6.4.2.2. These gas pockets must be vented for a spacecraft application.

6.4.3 Wire Construction - Two high voltage wire configurations are shown in Figures 6.4.3.1 and 6.4.3.2. The normal high voltage wire has higher field stress at the surfaces of the conductor as shown by the analytical calculation of Figure 6.4.3.3.

6.4.4 Transformers - An acceptable method for transformer lead connections is shown in Figure 6.4.4.1. This method has been used successfully by the Jet Propulsion Laboratory for several high voltage applications.

6.5 Circuit Boards - The voltage on a circuit board should be limited to 1000 volts peak as outlined in paragraph 3.3 of Reference 1. When voltages greater than 1000 volts peak are imposed, properly designed standoffs should be used to decrease the probability of tracking and flashover. Some other design criteria recommended for circuit boards and interconnections are described below.

6.5.1 Terminations - Some sketches of acceptable and unacceptable soldered terminations are shown in Figure 6.5.1.1, 6.5.1.2 and 6.5.1.3.

6.5.2 Standoffs and Feed Throughs - Standoffs and feed-throughs should be solder-balled. This may require a waiver to NASA solder specifications. The solder ball will be made after the connection is properly soldered per the appropriate NASA specification. The radius of the solder ball facing the ground plane should be at least 1/6 of the value of the spacing between the solder ball and ground plane or adjacent high voltage circuit. This low ratio decreases the voltage gradient at the surface of the solder ball and decreases the probability of corona. When large spacings are involved the solder ball should have at least 3.1 millimeters (0.125 inch) diameter. These solder balls must be properly secured to eliminate any dynamic vibration and acoustic problems (see Figure 6.5.2.1).

6.5.3 Flashover - A flashover will generate a large voltage transient that may overstress sensitive circuitry. Flashover can occur between some suppressed relay contacts without damage to other

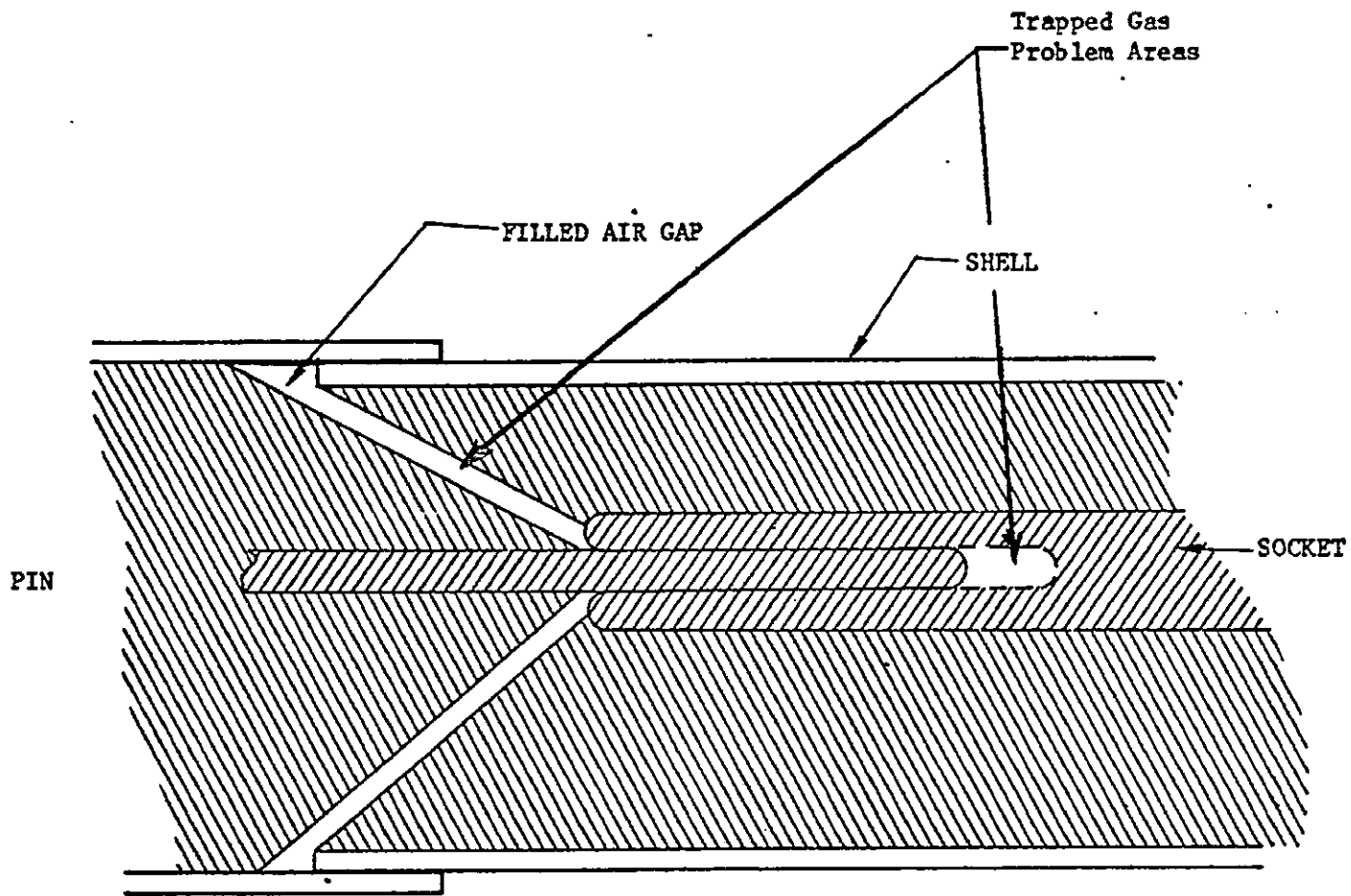

FIGURE 6.4.2.2 HIGH VOLTAGE CONNECTOR CONCEPTUAL DESIGN

Note: The socket must be vented.

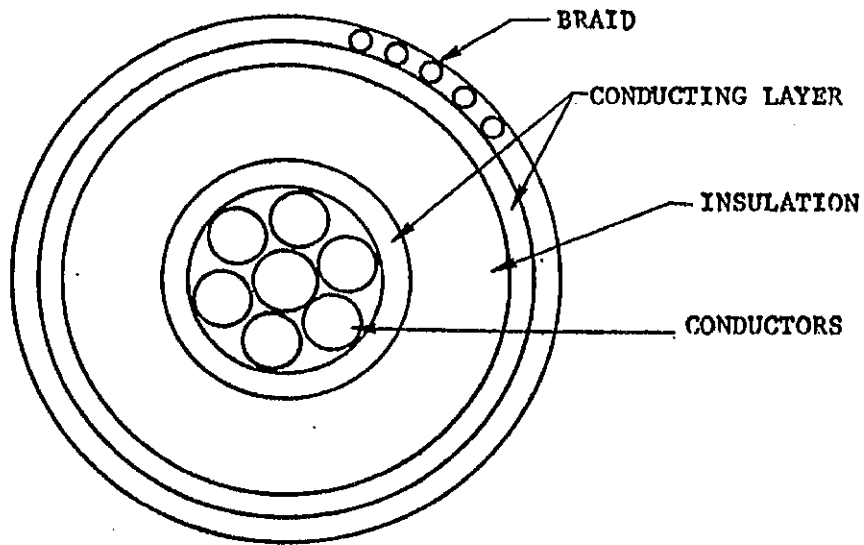

FIGURE 6.4.3.2 HIGH VOLTAGE WIRE

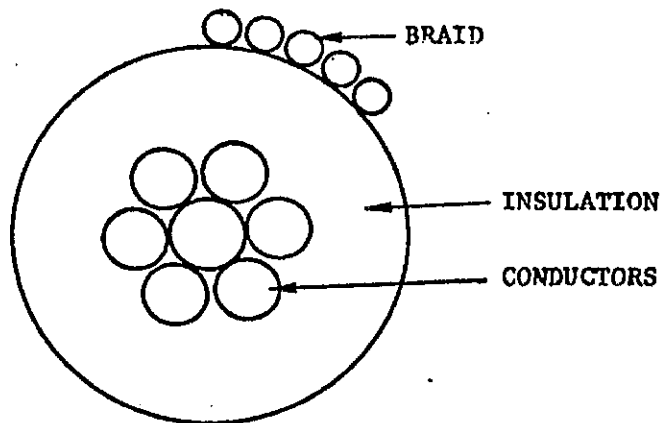
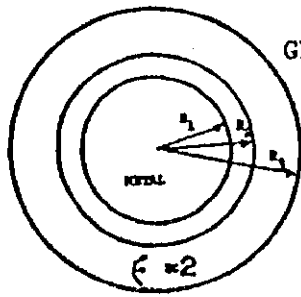
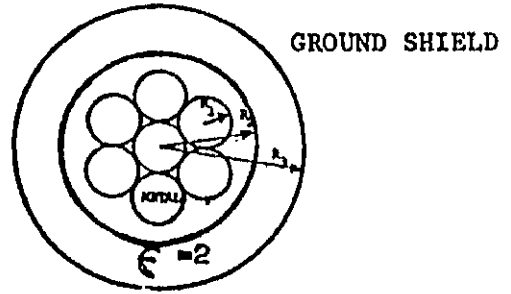

FIGURE 6.4.3.1 NORMAL WIRE CONSTRUCTION



SOLID CONDUCTOR COAXIAL CONFIGURATION



STRANDED WIRE COAXIAL CONFIGURATION

### Stranded Versus Round Wire Inner Conductor

In the above sketch are shown an inner conductor made of stranded wires and another of a single round wire. The gradient associated with a voltage applied to the stranded inner conductor is much greater than that of the round wire, inasmuch as the gradient is dependent upon the radius of the strands. Therefore, solid conductors are recommended for high voltage applications.

Example: 1) Let the surface at  $R_2$  be an equipotential surface in each instance; 2) let the ratio of  $R_2/R_1 = R_3/R_2$  for the round wires and  $R_2/R_1 > R_3/R_2$  for the stranded wires and; 3) let  $\epsilon_1 = \epsilon_2$ . Then the voltage across the inner insulation  $R_1$  to  $R_2$  is.

Stranded Wire

$$V_1 = V_T \left[ \frac{K_1}{0 + K_1} \right] \text{ or } V_1 \approx V_2 \text{ where } K_1 = \epsilon_2 \log_e \frac{R_2}{R_1}$$

Solid Wire

$$V_1 = V_T \left[ \frac{K_1}{K_2 + K_1} \right] \text{ or } V_1 = 1/2 V_2 \quad K_2 = \epsilon_1 \log_e \frac{R_3}{R_2}$$

Thus solid wire is preferable.

$V_T =$  applied voltage

FIGURE 6.4.3.3 COAXIAL CONFIGURATIONS

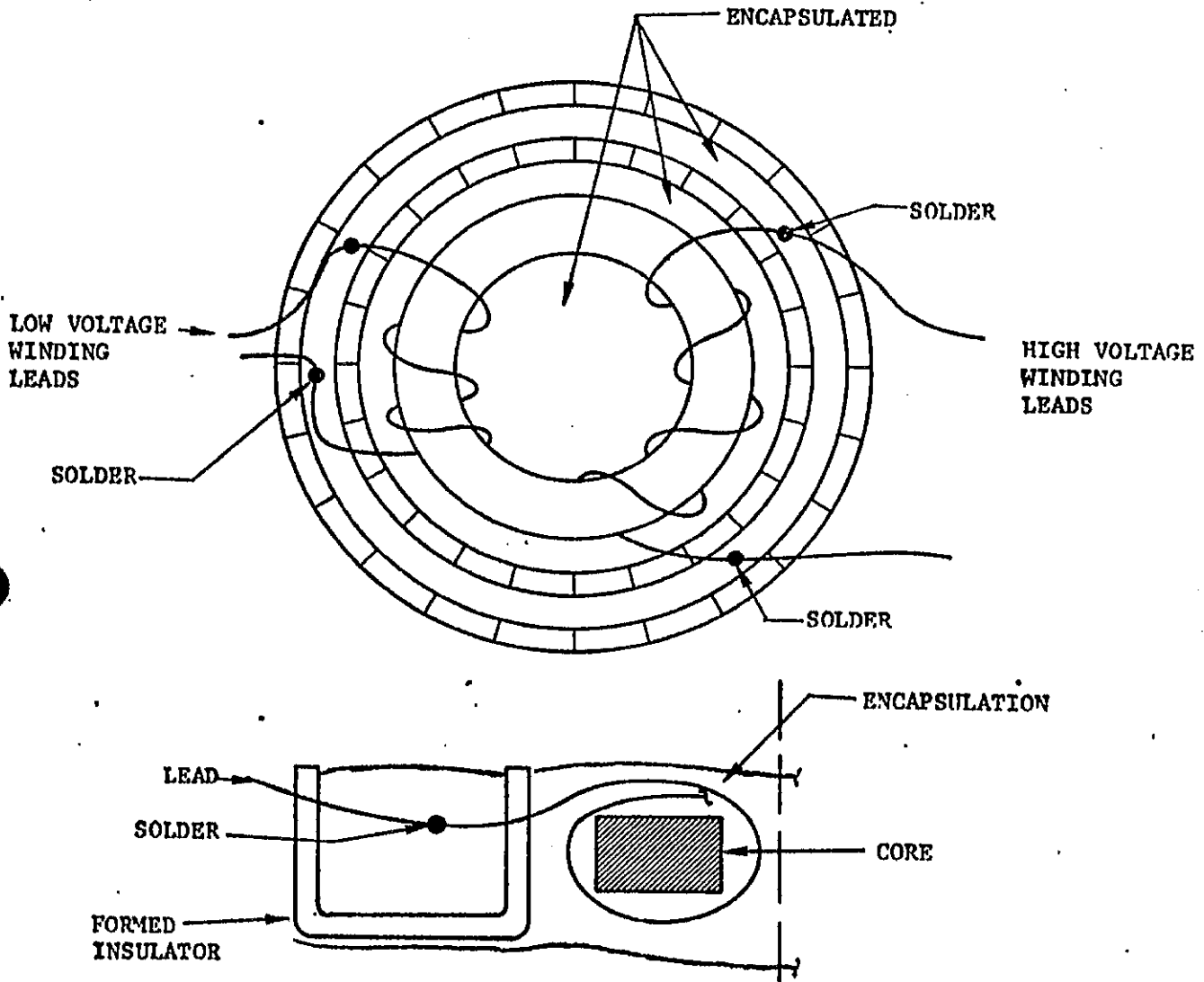

FIGURE 6.4.4.1: HIGH VOLTAGE TRANSFORMER

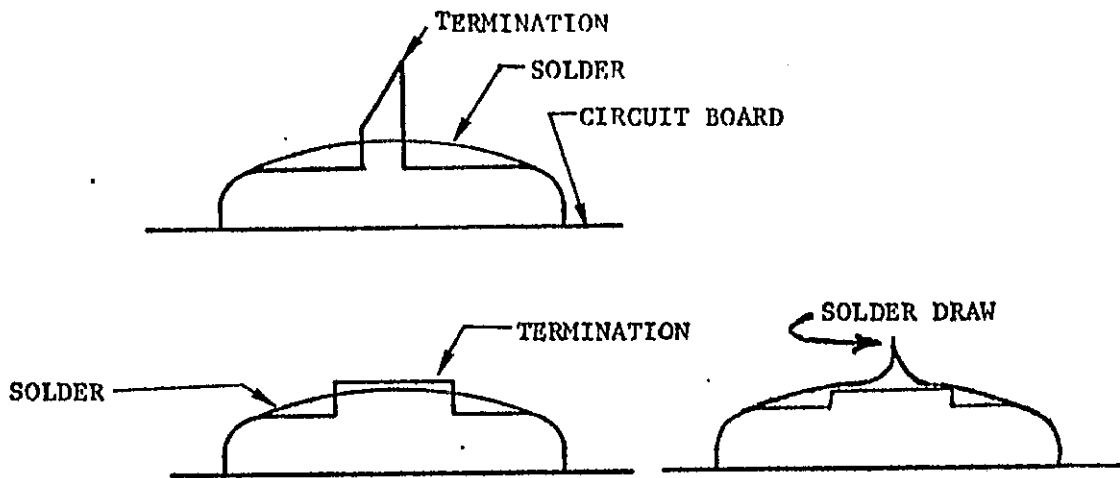

FIGURE 6.5.1.1 UNACCEPTABLE SOLDERED TERMINATIONS

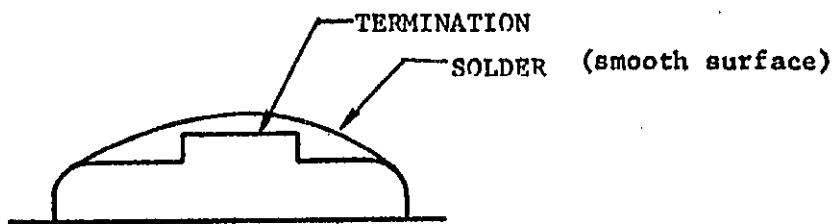

FIGURE 6.5.1.2 ACCEPTABLE TERMINATIONS

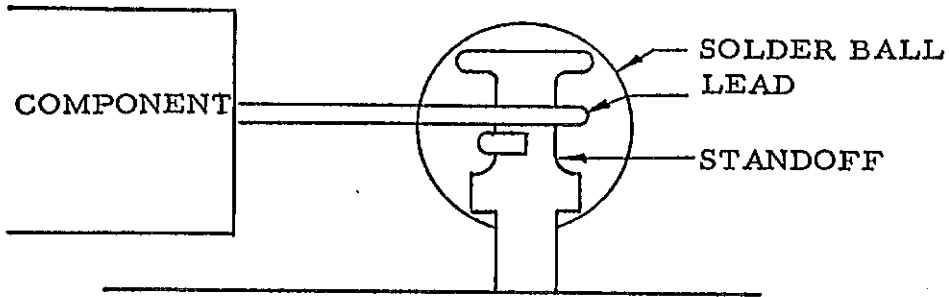

FIGURE 6.2.1: ACCEPTABLE STANDOFF CONNECTION

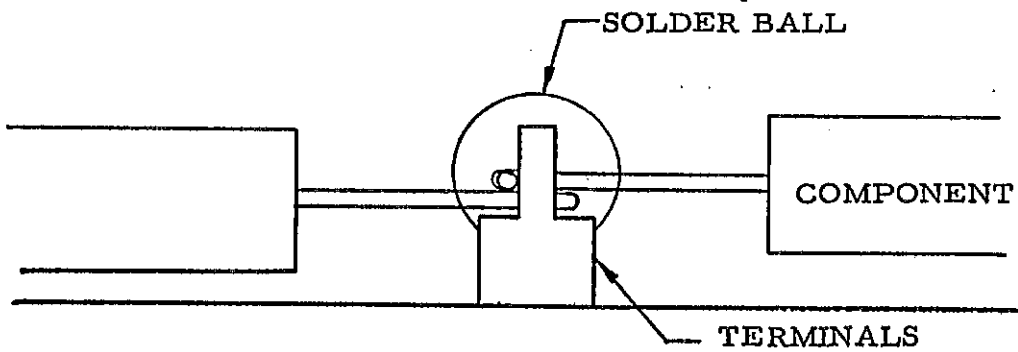

FIGURE 6.5.1.3: ACCEPTABLE COMPONENTS INTERCONNECTION



circuitry. Circuit boards and closely spaced terminations should not be subjected to high voltage flashover in vacuum. The initial flashover voltage as a function of frequency of several materials is given in Figure 6.5.3.1 for the configuration shown in the sketch. As the spacing is increased, the flashover voltage increases as shown in Figure 6.5.3.2. Since only the frequency effects of flashover were shown in Figure 6.5.3.1, it is necessary that the direct current and impulse voltage flashover also be considered and defined. The impulse voltage can be considered the same as the voltage transient superimposed on a direct or alternating voltage. These effects are shown for glass cloth in Figure 6.5.3.3.

6.5.4 Dielectric Strength - The dielectric strength or the working stress as a function of frequency for several materials is given in Figure 6.5.4.1. The values shown are those derived by test at 23°C, for one minute. These values must be derated for long life as demonstrated in Section 6.8.

6.5.5 Creepage and Tracking - Creepage and tracking are unlike flashover. Flashover occurs between two oppositely charged electrodes along an electric field line. Creepage or tracking occurs along the surface, regardless of the surface shape, between two oppositely charged electrodes. Some methods used to decrease creepage and tracking are illustrated in Figure 6.5.5.1.

6.6 Multiple Dielectrics - Multiple dielectrics can be used advantageously for some high voltage insulation systems. When more than two materials are used the materials should be selected on the basis of dielectric strength, dielectric constant, porosity, and outgassing. Theoretically, best results can be achieved if all the materials selected have the same dielectric strength. All dielectric materials should be homogenous, non-porous products with little residual outgassing as a function of temperature and pressure.

The material with the highest dielectric strength should be placed next to the conductor with the highest field gradient, i.e., the conductor with the smallest radius. Some examples of multiple dielectric applications are given below. In these examples, consider the unit to be insulated as a coaxial configuration:

The voltage distribution between coaxial conductors is shown in Figure 6.4.3.3 for solid homogeneous insulating material without cracks, bubbles, or voids. In this configuration the voltage stress (volts per mm) is greatest adjacent to the high-potential component.

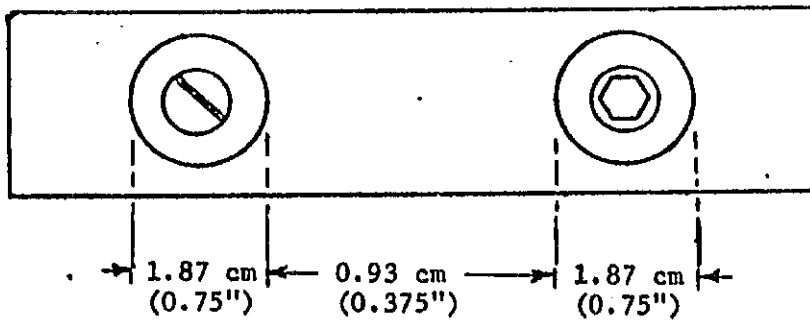

INITIAL VALUES FLASHOVER STRENGTH - KVrms

Material	Frequency - Hertz						
	60	1K	40K	200K	2 Meg	20 Meg	100 Meg
Polystyrene	13.2	13	13	12.5	12.5	12	11
Teflon	15.5	14.9	14.7	14.3	13.1	12.7	12
Asbestos	10	9	8.6	8.1	3.0	1.7	1.5
Mica	9.7	9.8	9.6	9.6	8.2	8.0	6.3
Glasscloth	13.5	13.5	13.5	13.2	12.9	10.4	9.7 (Max.)
" "	9.5	9.2	8.3	8.2	6.5	2.5	2.3 (Min.)
Foam	13.5	12.9	12.4	11.9	8.5	7.0	2.0
Ceramics	8.6	8.3	8.3	7.8	5.0	4.7	4.7

FIGURE 6.5.3.1 FLASHOVER STRENGTH OF SEVERAL MATERIALS

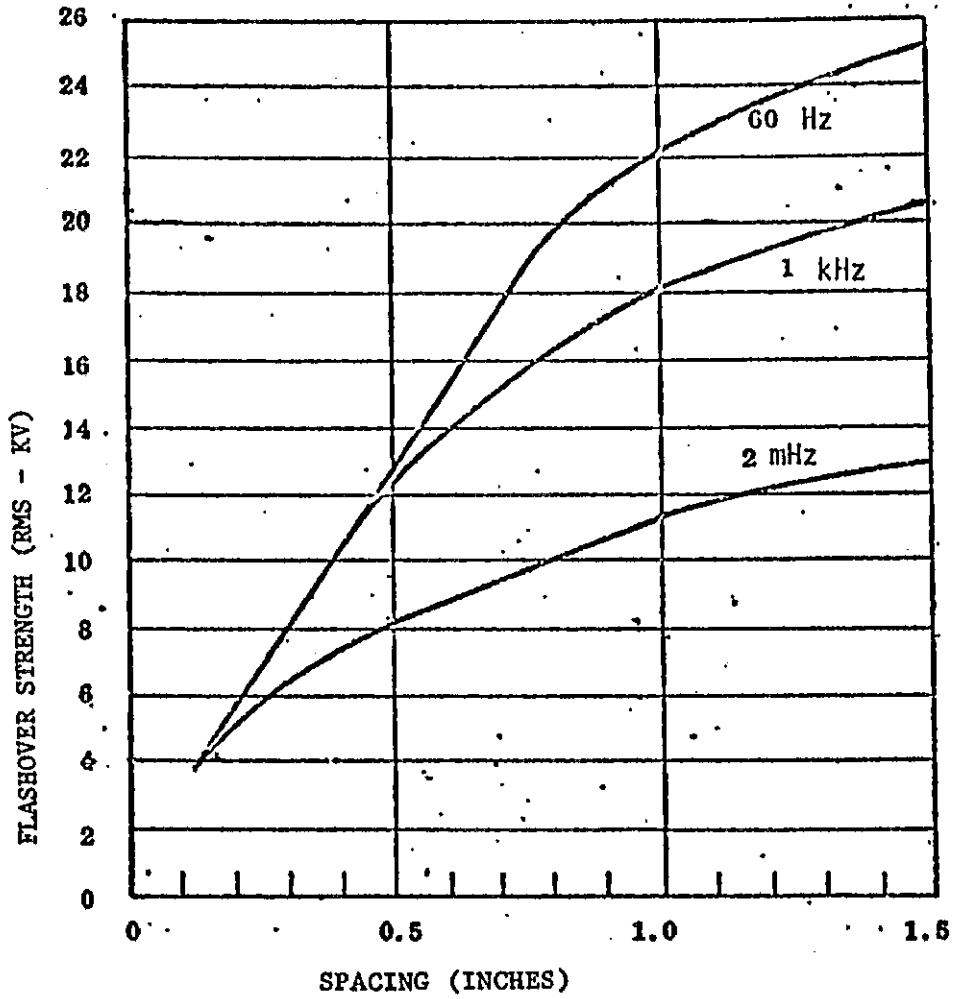

Note: 1 inch = 2.54 centimeters

FIGURE 6.5.3.2 EFFECT OF SPACING ON FLASHOVER STENGTH

<u>GLASS CLOTH</u>		
<u>Test</u>	<u>Maximum KV</u>	<u>Minimum KV</u>
60 Hz	15.3 (peak)	13.4 (peak)
DC Positive	15.5	13.9
DC Negative	15.9	14.9
Impulse Positive	17.9	16.2
Impulse Negative	22.0	16.9

ENVIRONMENT EFFECT ON FLASHOVER 60 HZ

<u>GLASS CLOTH</u>					
	<u>1 Hour</u>	<u>1 Day</u>	<u>1 Week</u>	<u>1 Month</u>	<u>6 Months</u>
85C (dry)	7.8			9.0	9.4
125C (dry)	7.0			9.4	9.3
25°C (100 RH)	9.5	3.6*	2.5*	2.5*	
50°C (100 RH)	8.8	2.4*	2.4*	2.4*	

POLYSTYRENE

25°C (100 RH)	10.7				5.5
50°C (100 RH)	10.3			6.2	5.1

\* Internal Flashover

FLASHOVER SAFETY FACTORS

- Humidity** - A safety factor of 2 is recommended where humidity can go to 100% with condensation.
- Contamination** - Where dirt, dust and residual ions from plating baths, etc. may contaminate the surface between electrodes, the flashover (creepage) path should be made to be 2 or 3 times the minimum air spacing.

FIGURE 6.5.3.3 FLASHOVER STRENGTH COMPARISON (KV)

Initial Values Electric Strength - Volts/mil\*\* (rms)  
at Several Frequencies

<u>Material</u>	<u>Thickness</u> (mils)	<u>60</u>	<u>1K</u>	<u>40K</u>	<u>200K</u>	<u>2m</u>	<u>20 meg</u>	<u>100 meg</u>
Asbestos Fabric Phenolic Filled	32	110	63 heats*		30 Excessive* Heating			
Glass Cloth Epoxy Base Laminate	45	774	647	404	247	46 Heats*	21 Heats*	
Paper Phenolic Grade XX	32	1206	1067	-	-	78 Heats*	40 Heats*	20 Heats*
Polyethylene Unpigmented	30	1091	965	500	460	343	180	132
Teflon	30	850	808	540	500	375	210	143
Kel F	20	2007	1478	1054	600	354	129	29 Heats*
<u>Foams</u>								
ISO Cyanate	100	123	118	112	104	64	43 Heats*	U
Syntactic	100	50	54	52	51	32 Heats*	18 Heats*	U
Alumina	65	499	461	455	365	210	112	74

One Minute to Breakdown  
Parallel Electrodes

\* The insulation temperature increases 20°C above the ambient in one minute.

\*\* 1 mil = 0.025 millimeter.

FIGURE 6.5.4.1 BREAKDOWN STRENGTH OF SEVERAL MATERIALS

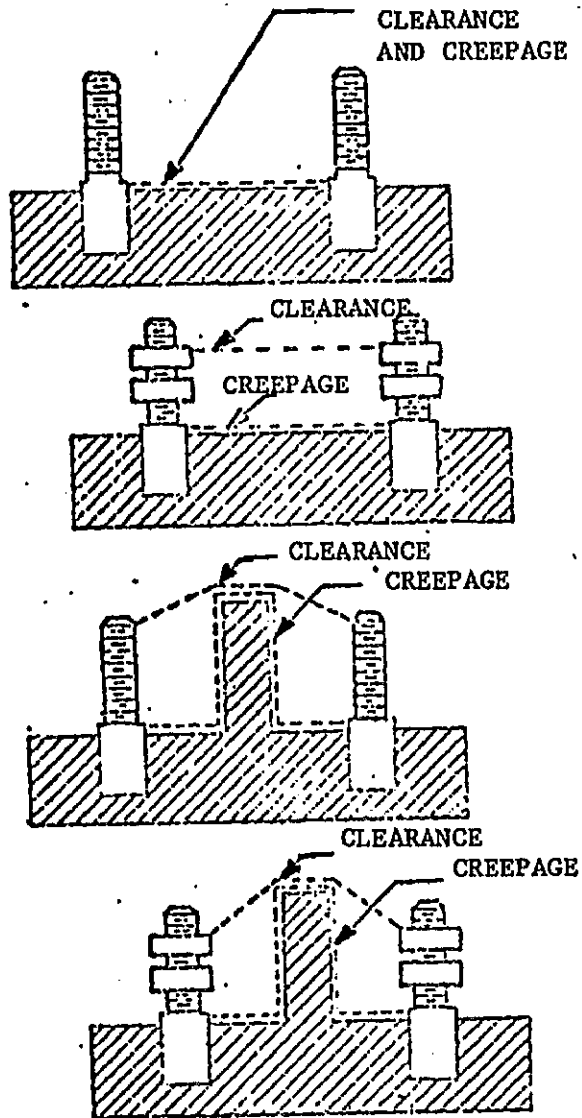

FIGURE 6.5.5.1 DEFINITIONS OF CREEPAGE & CLEARANCE SPACING

If a small air space (less than 1 millimeter) is entrapped near the high potential conductor, the voltage distribution will be altered as given in Figure 6.6.2. This shows that the voltage stress across the air may be twice that across an equal thickness of solid insulation. This also shows the need to minimize the electrical stress across the air gap.

The ideal method of insulation application to a coaxial construction is that shown by Curve D of Figure 6.6.3. By proper selection of materials, the voltage gradient can be made nearly constant from the small radius conductor to the grounded shell.

This same technique can be applied with little error between a small round conductor and a ground plane. Consider the ground plane to be a large radius conductor and apply the appropriate mathematical equations. When two round conductors are involved, assume a ground plane at the minimum gradient and apply the insulation to each conductor. For identical conductors, the insulation is assumed to be the same on each conductor.

**6.7 Hermetic Seals** - Pressurized systems are sometimes required when a high voltage system must operate in a soft vacuum environment of  $6.6 \times 10^3 \text{N/m}^2$  (50 torr) to  $1.33 \text{N/m}^2$  ( $1 \times 10^{-2}$  torr). At these pressures, the gas is easily ionized and can produce corona, noxious gases, and eventual breakdown. Thus a need for pressurization arises. Likewise, if some high voltage modules are located near outgassing products or gas producing sources, they also require pressurization.

Normally, a pressurized module can operate as well in space as on the workbench. This assumes the leak rate is such that the internal pressure is equal to or above one Earth's atmosphere during the life of the mission. To assure a slow leak rate many designers insist upon a small quantity helium (say 10%) be placed inside the sealed container. On paper this looks fine because 10% helium has little effect upon the breakdown strength of the pressurizing gas. An example is shown in Figure 6.7.1, for helium-oxygen mixtures. A slight over pressure of say 10 to 20% of the gas mixture will give the same breakdown or corona onset voltage as the principle pressurizing gas. A problem occurs when the leak rate of helium into the encapsulated parts of the module is excessive. For instance, if a module with the encapsulated circuit is installed in a pressurized can, and the canister evacuated and repressurized with the helium gas mixture, the helium will tend to diffuse and pressurize any small voids within the module. Since

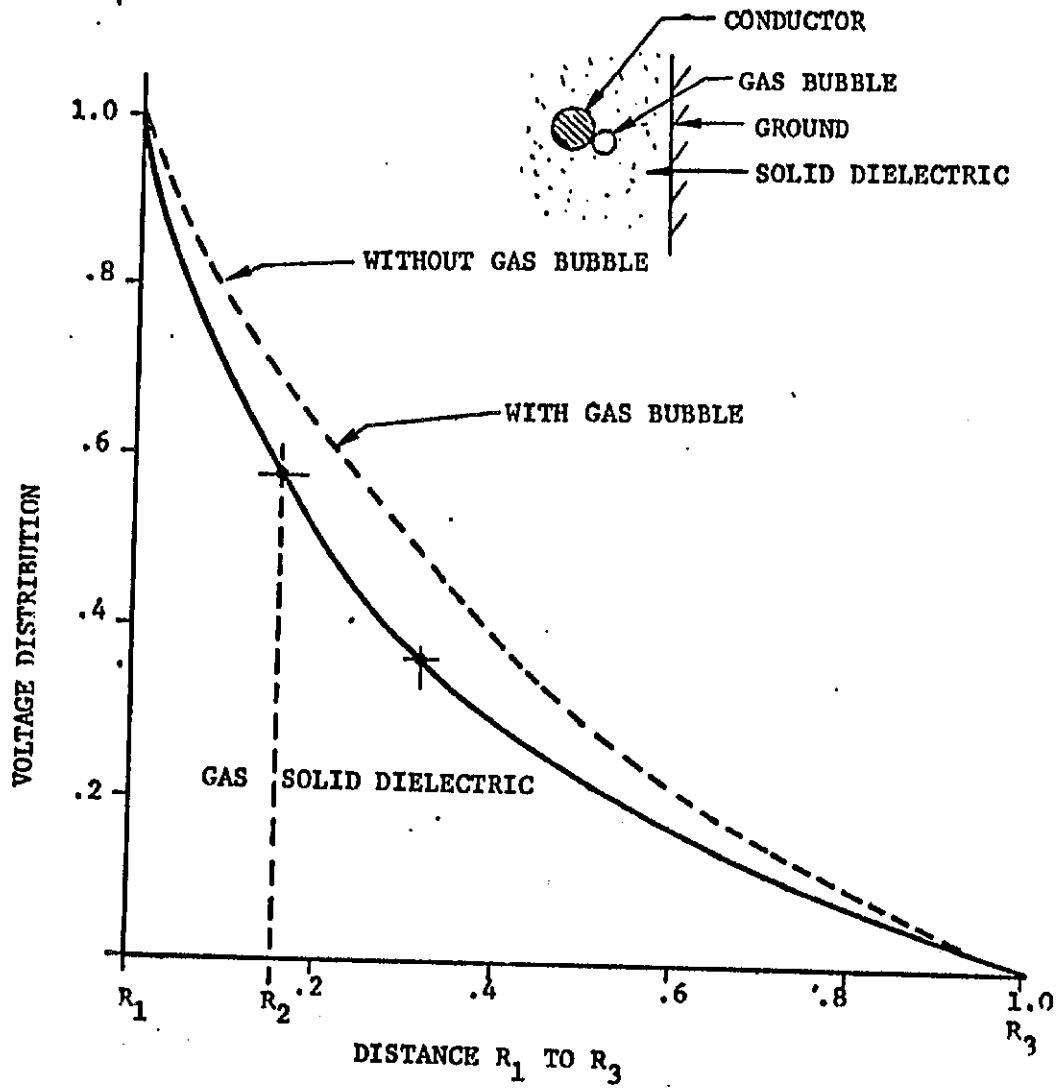
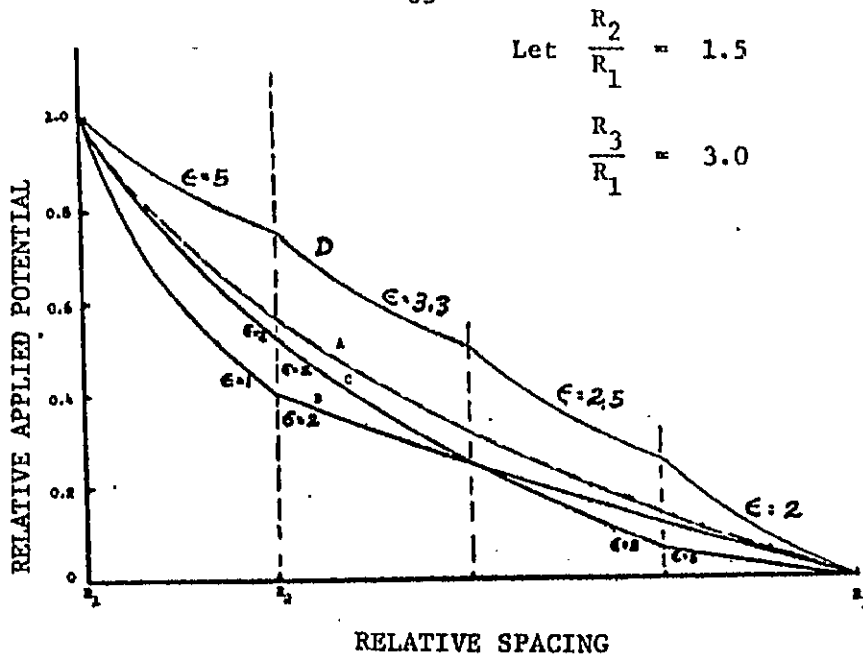

FIGURE 6.6.2: VOLTAGE DISTRIBUTION IN GAS-SOLID DIELECTRIC





Let:  $R_3$  be at ground potential

$R_1$  be at maximum applied potential

Then insulation systems can be evaluated thus:

Curve A: Let  $\epsilon_1 = \epsilon_2$ ; the voltage varies exponentially from a maximum at  $R_1$  to 0 at  $R_3$ .

Curve B: Assume a gas void surrounds  $R_1$  between  $R_1$  and  $R_2$ . Then the voltage gradient across the gas voltage will be much greater than the gradient across the solid insulation.

Curve C: Another poor design feature is to coat the ground plane with a high dielectric constant material. Again the voltage gradient will be increased across the insulation surrounding  $R_1$ .

Curve D: The best design practice is to place insulation with high dielectric constant next to the inner conductor.

FIGURE 6.6.3 APPLYING MATERIAL WITH VARIOUS DIELECTRIC CONSTANTS

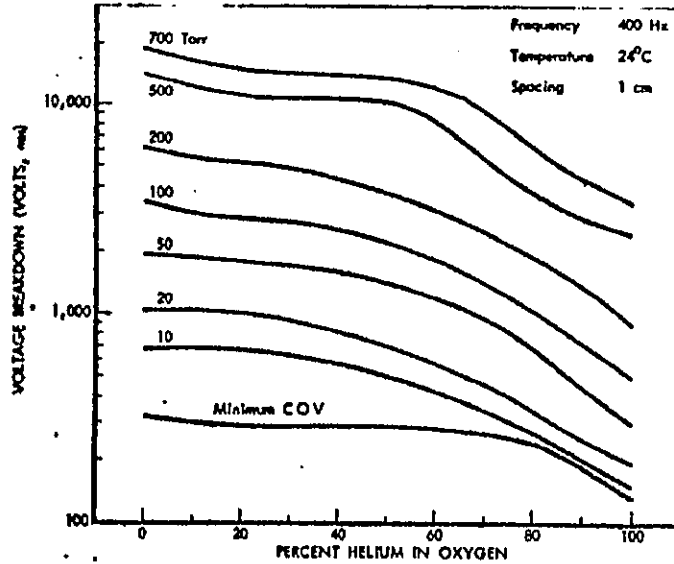

VOLTAGE BREAKDOWN OF HELIUM-OXYGEN GAS MIXTURES BETWEEN 5.0-CM-DIAMETER PARALLEL PLATES

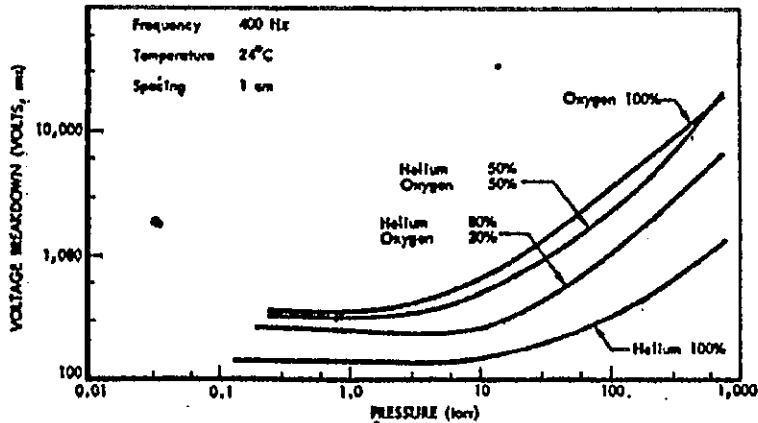

VOLTAGE BREAKDOWN OF HELIUM-OXYGEN GAS MIXTURES BETWEEN 5.0-CM-DIAMETER PARALLEL PLATES

#### Assumptions and Constraints

Temperature:  $23 \pm 2^\circ\text{C}$   
 Limitations:  $-60^\circ\text{C}$  to  $200^\circ\text{C}$   
 Pressure Limitations:  $1.33 \times 10^{-2}$  to  $1.33 \times 10^6 \text{N/m}^2$  ( $1 \times 10^{-4}$  to  $1 \times 10^4$  torr)  
 Electrodes: Parallel Plates - 5 cm diameter  
 Material: Steel  
 Spacings: 0.1 to 20 millimeter  
 Frequency: 400 Hertz

FIGURE 6.7.1 HELIUM OXYGEN MIXTURES

nearly pure helium has very low breakdown compared to other pressurizing gases, this can create a corona problem and possibly lead to a system failure.

Another problem exists when an insulating material cracks internally between high voltage components and low voltage components or ground plane. At this time, the crack will have very low pressure, probably that produced by the outgassing products. Since the crack has the lower pressure, it will fill with helium rather than the pressurizing gas. If the electrical circuits are energized at this time the gas will ionize at low gas pressure, possibly generating corona and an eventual arc.

6.8 Insulation Life - The estimated operating life of an electrically insulated product is dependent upon the electrical properties of the electrical insulation material, the applied voltage stress and its duration, and the materials application workmanship. Each electrical insulating material will withstand voltage stress for several years if the maximum voltage gradients within the material are kept very small, i.e. less than 800 volts per millimeter (20 volts per mil). However, this restriction increases insulation weight. Since spacecraft designers are required to minimize weight and volume, the long life aspect is a tradeoff which sometimes must be compromised.

Life characteristics of insulating materials are derived from curves that show log life versus reciprocal absolute temperature. A modification of this plot is one for log life as a function of voltage stress. A typical plot is shown for a silicone rubber product, RTV-60, in Figure 6.8.1. Another plot for the same material is shown in Figure 6.8.2. This plot shows the life characteristic of various thicknesses of RT-60 in an ionizing or near ionizing atmosphere.

Plots like these should be made for each insulating material by the insulation design engineer before the material is accepted for a high voltage application. These plots are normally based on data obtained from a qualified test laboratory.

SOLID RTV-60  
23°C OPERATING TEMPERATURE

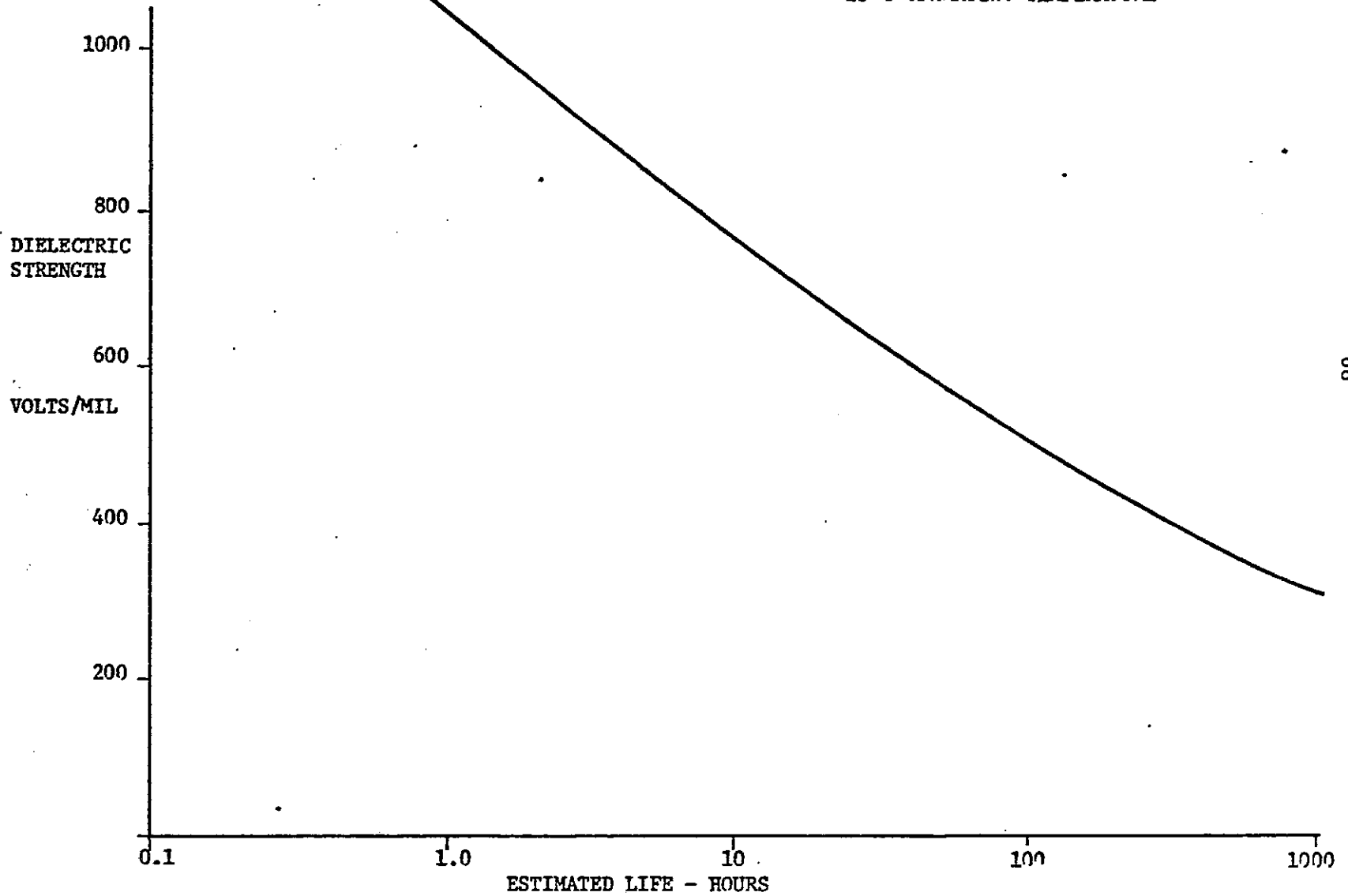

Note: 1 mil = 0.025 millimeters

FIGURE 6.8.1: EFFECT OF VOLTAGE ON LIFE OF RTV-60

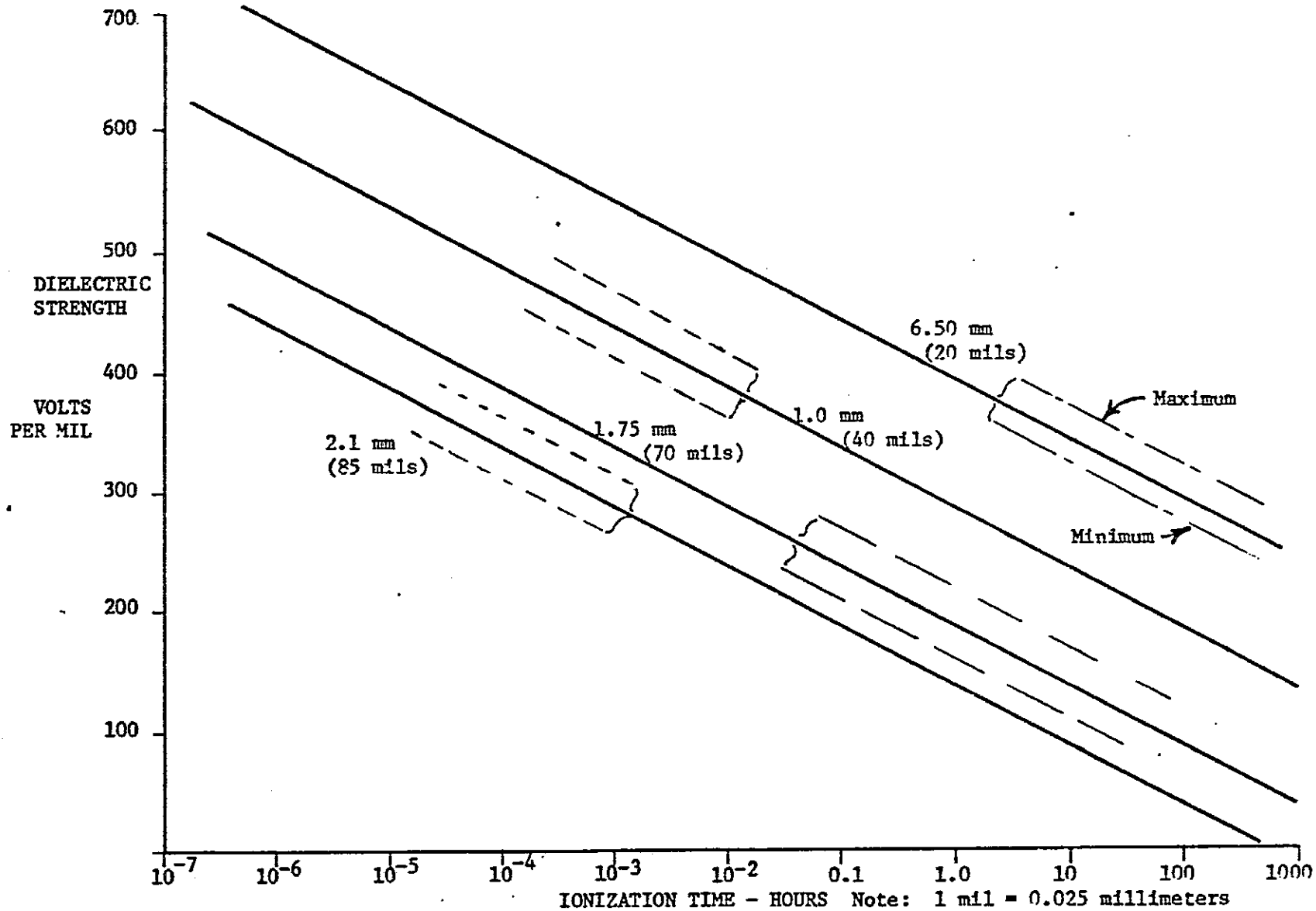

FIGURE 6.8.2: DIELECTRIC STRENGTH OF RTV-60 AS A FUNCTION OF IONIZATION TIME

## 7.0 TESTING

Non-destructive corona tests are used for the qualitative evaluation of electrical/electronic parts and insulation systems where parts refer to electrical parts such as resistors, capacitors and coils.

**7.1 Background** - Historically, detecting corona was limited to audio and visual methods. This was accomplished by energizing the hardware with high voltage and either listening for a "hissing" sound or looking for a violet glow produced by the brush type corona discharger. This approach became obsolete when either some or all of the circuit was integral within the mechanical parts or enclosed in boxes. Also, the electromagnetic noise produced by the applied high voltage often generated noises much greater than that generated by the small brush discharges of corona. The next (evolutionary) successful method for detecting corona was that of power factor changes. It was found that when a corona discharge occurred, a sudden change in power factor was recorded. This method of corona detection was used until 1940. Since 1940 the oscilloscope has been used to detect the high frequency impulses of corona.

During the 1940 to 1950 time period, airplanes and missiles were developed for high-altitude flight. These vehicles required high voltage electronics which could no longer be tested under terrestrial conditions. Therefore, new thermal vacuum testing techniques were established which included corona detection by electromagnetic radiation. More recently with the advent of orbital spacecraft, new corona test procedures are required for testing high voltage equipment in thermal vacuum. Contemporary methods were pulse-height analyzers (in a limited number of applications) connected to cathode-ray tubes and continuous recorders.

**7.2 Testing and Detection** - Generally, the test philosophy for electronic parts and hardware should be that flight parts and engineering, development, prototype and qualification equipment may and should be thoroughly and extensively tested and stressed repeatedly to establish the applicability and design margin of the design. Qualification equipment should first be tested to acceptance levels to verify workmanship and to identify infant mortality reasons for failure. Flight equipment should never be stress tested or be electrically tested repeatedly. One test of flight equipment will verify workmanship and expose infant mortality conditions. Electrical stress, a cumulative condition, can jeopardize the imposed operating life of a flight device.

Corona testing is normally performed in conjunction with other electrical testing of the hardware, usually as a special test for components or as an inclusion to the thermal vacuum tests for hardware. Thus, a positive method of detecting corona without affecting other important data is required. Under special circumstances, corona can be observed visually. However, as in the

case of packaged devices, direct observation is impractical if not impossible. Likewise, the direct monitoring of input and output signals in some hardware is not sensitive enough to detect corona before breakdown and failure actually occurs. Therefore, the electrical discharges associated with corona, which generally produce an electromagnetic interference, are secured with a corona detection network. The signal from the corona detection network is then either passed through a wide-band RF receiver or displayed on an oscilloscope. However, the display equipment must have a fairly wide frequency range.

7.3 Equipment Testing - In general, if equipment to be tested is unshielded, a probe can be located near the equipment, otherwise it is necessary to "build in" a detector. Some equipment such as photomultipliers are good detectors in themselves and require no additional detector when tested. The normal operating characteristics of the items to be tested should be thoroughly understood as a tool in recognizing off normal operation, curveshapes, transients, and loading effects. Corona, when present, will be superimposed upon these waveshapes. It is the responsibility of the cognizant design engineer and corona test engineer to differentiate between corona pulses and normal operation.

7.3.1 High Voltage Testing - AC high voltage testing is normally voltage endurance as a function of time. The voltage a piece of equipment can withstand depends to a great extent on the length of time that voltage is applied. This relationship is not linear, but has the general characteristic that, if the voltage is lowered slightly, the withstand time is greatly increased. AC testing is usually considered a go/no-go type proposition. Voltage is run-up to a specified value; if the sample breaks down within a specified time it is no good, if it does not break down it is assumed good.

DC high voltage testing procedures are usually different than those for AC. Leakage current is measured as voltage is raised, as long as current varies approximately linearly with voltage, the equipment is in good condition. In most cases (this depends on the particular insulation materials involved) there will be a knee in the curve of voltage versus current. Prior to breakdown as the breakdown point is approached, the leakage current starts increasing at a higher rate, followed by an avalanche current. On certain newer materials, this knee is almost a right-angle bend; breakdown is reached at about the same time the first sign of the knee appears. The rate of application of voltage will have some effect on the breakdown point.

High potential testing is normally performed to life test a part or device. The rate of voltage application is critical in this case, so as not to prematurely and abnormally degrade

insulation. When any tests are made in a thermally controlled vacuum system, the vacuum chamber and fixtures require thorough cleaning between tests.

For high-temperature high-voltage testing, the chamber feed-through corona is the only valid corona reading obtainable due to the fact that the items being tested are subject to radiation and conduction to cold insulators causing the center of the item to be hotter than its outer edges; this makes data analysis difficult due to ambiguities with respect to localized gas pressures. Both pressure and low temperature testing conditions are free of these ambiguities and thus corona detection, if it exists and if the sensor is properly installed, is readily obtained.

**7.3.2 Parts Tests** - A part that is to be evaluated for the partial discharges of corona should be entirely insulated and conditioned as it will appear in application. This includes cleaning and potting of parts, and the cleaning and solderballing of the electrodes. That is, if the part is normally attached to a printed circuit board and the part and board is conformally coated, the test article should be prepared in that manner. In addition, the spacing between the part and the ground plane should be kept the same as in the application. This includes upper, lower and side ground planes. These ground planes will limit the field gradients and the pressure-spacing dimensions for gaseous ionization and corona.

The vacuum chamber feedthroughs and connections must be free of sharp corners and edges in order to prevent ionization from the high voltage gradients present at the points. In addition there should be no gas pockets or outgassing materials associated with the chamber feedthroughs and specimen interface connections. These outgassing parts can create localized high pressure volumes near the test article which can cause ionization and/or corona. Indeed the test fixture is one of the most important parts of the test. Great care must be taken to get it in exact position during test installation, so that all connections and interconnections are solid, free of outgassing, and corona-free. Each type part should have its own fixture and non-similar parts should not be interchanged thereon.

Directly coupled capacitors, series resistors or RF coils are the best corona sensors for testing parts, insulated electrodes, and the gaseous breakdown between fixed electrodes. These sensors are simple, easily connected, and accurate.

**7.3.3 Circuit Tests** - Some simple circuit tests can be treated and tested as parts. More complicated circuits



require special tests or the addition of special detectors. A simple circuit can be that of a voltage divider network or a voltage multiplier. The more complicated circuits include the full power supply or the high voltage electronic system.

Since the simple circuits, detectors, and corona detection circuits were discussed in Paragraph 7.3.2, this paragraph will be devoted to the complex circuits.

A high voltage power unit can be instrumented in several ways as described in Table 7.3.3.1. There are many variations to these detection methods. However, when it is possible the output circuitry should be used without addition of RF coils, electrometers, or coupling capacitors. When the high voltage circuit is a photomultiplier or a pulse-height analyzer circuit, either can be used as a corona detector since they are designed to detect voltage discharges and impulses in the range of  $10^{-7}$  ampere. However, they should be allowed to operate continuously during the corona test. Another built-in detector is in the form of a resistor (approximately one percent of the value of the load resistor) in series with the load resistor. This resistor is used to measure output voltage and/or current of the power supply. Unfortunately it usually has a filter capacitor paralleled across it. If this resistor can be placed as an external circuit and the capacitor disconnected during the corona test, then the resistor can be used for a corona detector.

7.3.4 Systems Tests - A high voltage circuit within an electrical/electronic system is difficult to test and analyze unless the high voltage circuits are instrumented as described in Paragraph 7.3.3. When the circuits are not directly instrumented for corona detection then detection devices must be placed within the test facility and located as near as possible to the high voltage circuit. Applicable detectors for this purpose include: electrometers, photomultipliers, RF coils and ultrasonic detectors. All these detectors are subject to external RF electrical noise as well as to partial discharge radiated noise. Therefore, it is necessary to monitor the power return or common point ground for electrical impulses. RF coils are adequate for detecting these impulses. By placing the RF coil on the instrumentation or power ground leads, impulses generated by spurious noise from the outside equipment can be detected. When signals from the ground leads and the system corona detectors appear on the readout instrumentation simultaneously, it is probably that the signals were generated by extraneous noise sources. When single signals appear from only the corona sensors, it is due to corona. Pictures of corona and noise signals are shown in Figure 7.3.4.1. When the high voltage circuitry contains photomultipliers, pulse-height analyzers, or

Table 7.3.3.1. Circuit Instrumentation and Detection

<u>CIRCUIT</u>	<u>CORONA DETECTOR CONNECTION</u>	<u>DETECTOR</u>
1. Power Supply Sine Wave	Transformer high voltage winding ground return	Resistor
Square Wave	Capacitor coupling to high voltage winding	Capacitor
D.C. Output	A resistor in series with the loading resistor	Resistor
2. Electronic Load D.C. Steady-State	Place an electrometer plate or RF coil on the ground plane near the high voltage supply. The detector must not cause shorting of the high voltage	Electrometer or RF coil
Varying Voltage	Electrometer plate or coupling capacitor	Capacitor or Electrometer
Photomultiplier Pulse-height Analyzer	Use the output of the photomultiplier or pulse-height analyzer	Pulse-height detector

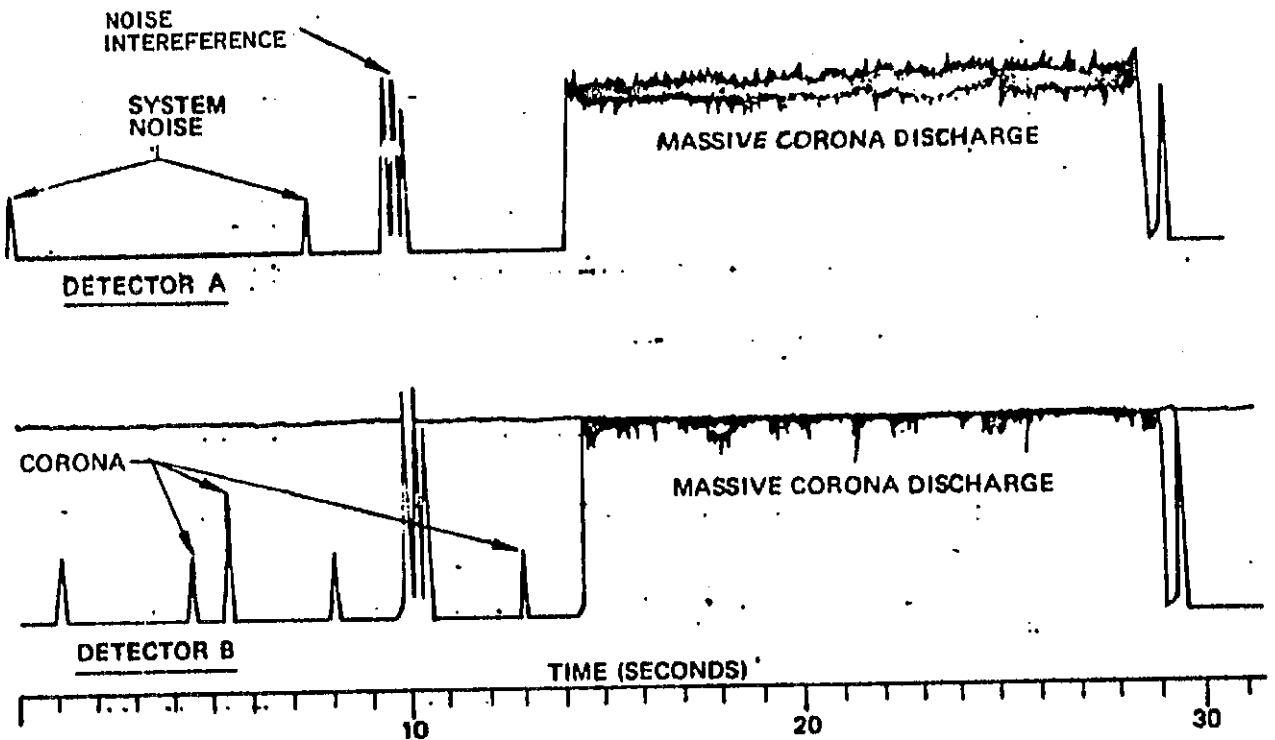

NOISE AND CORONA DISCHARGES RECORDED ON AN OSCILLOGRAPH

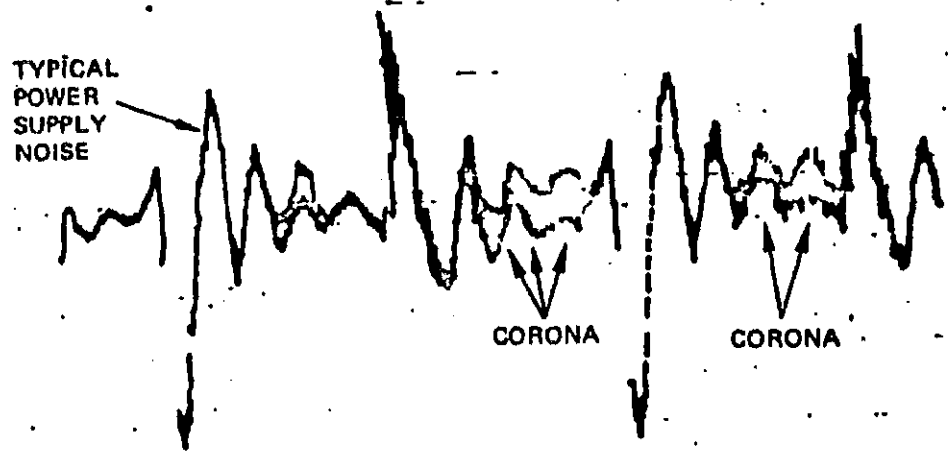

CORONA DETECTED BY RF COIL DISPLAY ON FIBER OPTICS RECORDER

FIGURE 7.3.4.1: NOISE AND CORONA RECORDINGS

other sensitive electron-counting circuitry, then the outputs of these electronic instruments can be used as corona detectors. It should be emphasized that the instrument must be free-running during the corona test rather than have limited digital averaged readout. This permits the impulses and groups of impulses to be identified more clearly for corona evaluation. When it is practical detectors should be attached directly to or near the test article. One such detector is a loop antenna which can be used to detect electromagnetic interference to determine the presence of corona. A circuit using a loop antenna is shown in Figure 7.3.4.2 for detecting corona one meter away from the test article. The anticipated frequency spectrums of corona signals are shown in Figures 7.3.4.3 and 7.3.4.4.

**7.3.5 RF System Tests** - RF Systems can be tested for corona and for multipactor by input-output measurements or voltage standing wave ratio measurements. The presence of multipactor is measured as a power change. That is, when the circuit has all components tuned to the resonant frequency, multipactor will be recorded as a decrease in decibels (mismatch) or as a decibel increase when the multipactor tends to match the circuits. Normally a power decrease will occur during multipactor. Corona will be present at pressures between  $6 \times 10^3 \text{ N/m}^2$  and  $0.1 \text{ N/m}^2$  and will be associated with a glow discharge which results in a power loss. The glow discharge and multipactor pressure regions are shown in Figure 7.3.5.1.

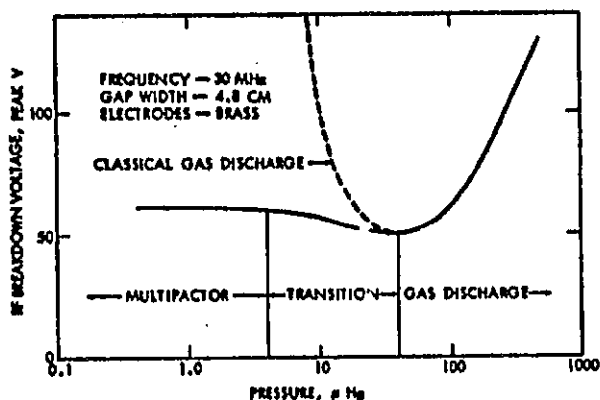

$$\text{One Micron} \approx 1.33 \times 10^5 \text{ N/m}^2$$

Figure 7.3.5.1. Paschen's Curve as Modified by Multipacting

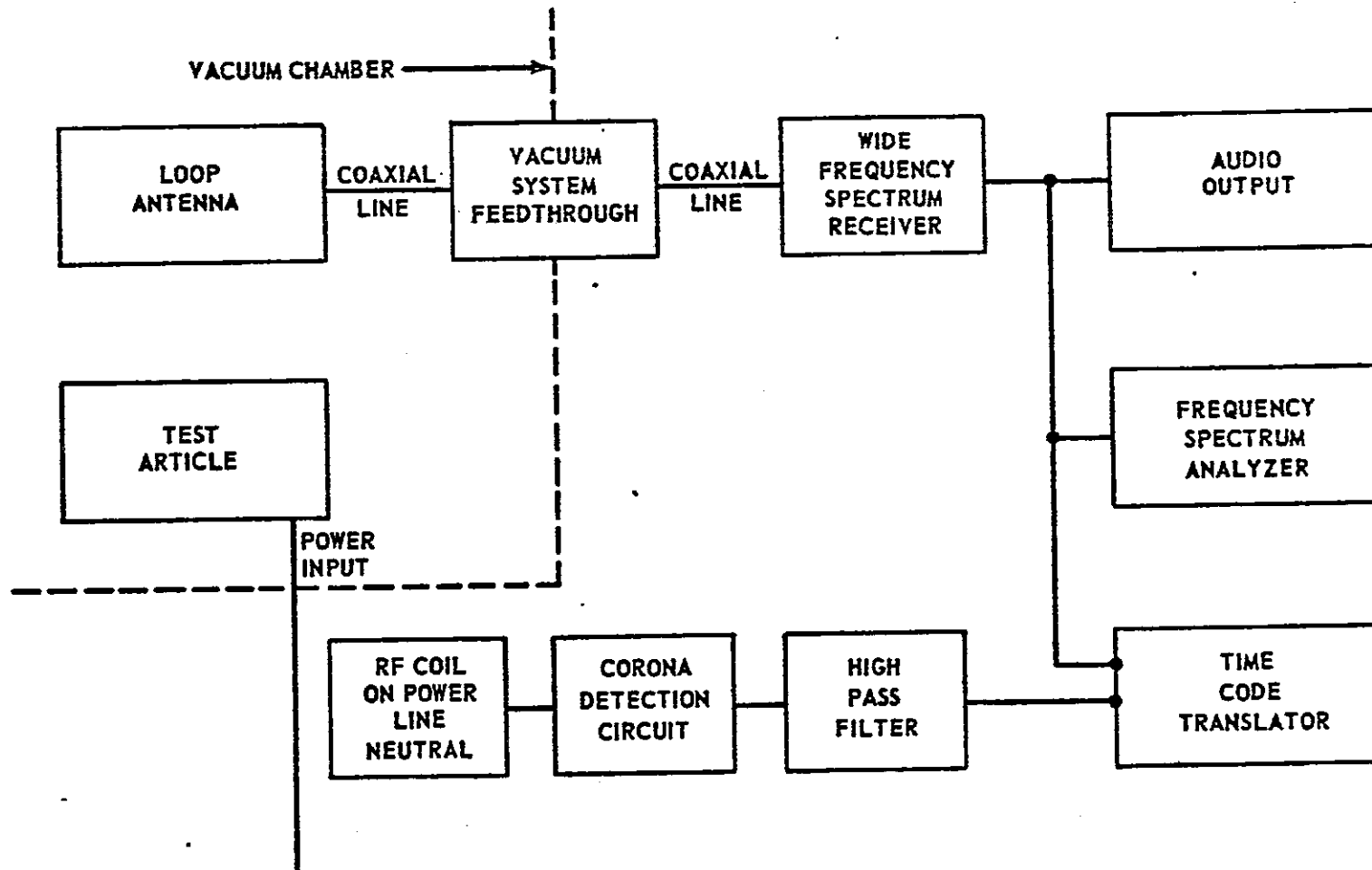

**FIGURE 7.3.4.2 R.F. SYSTEM SCHEMATIC DIAGRAM**

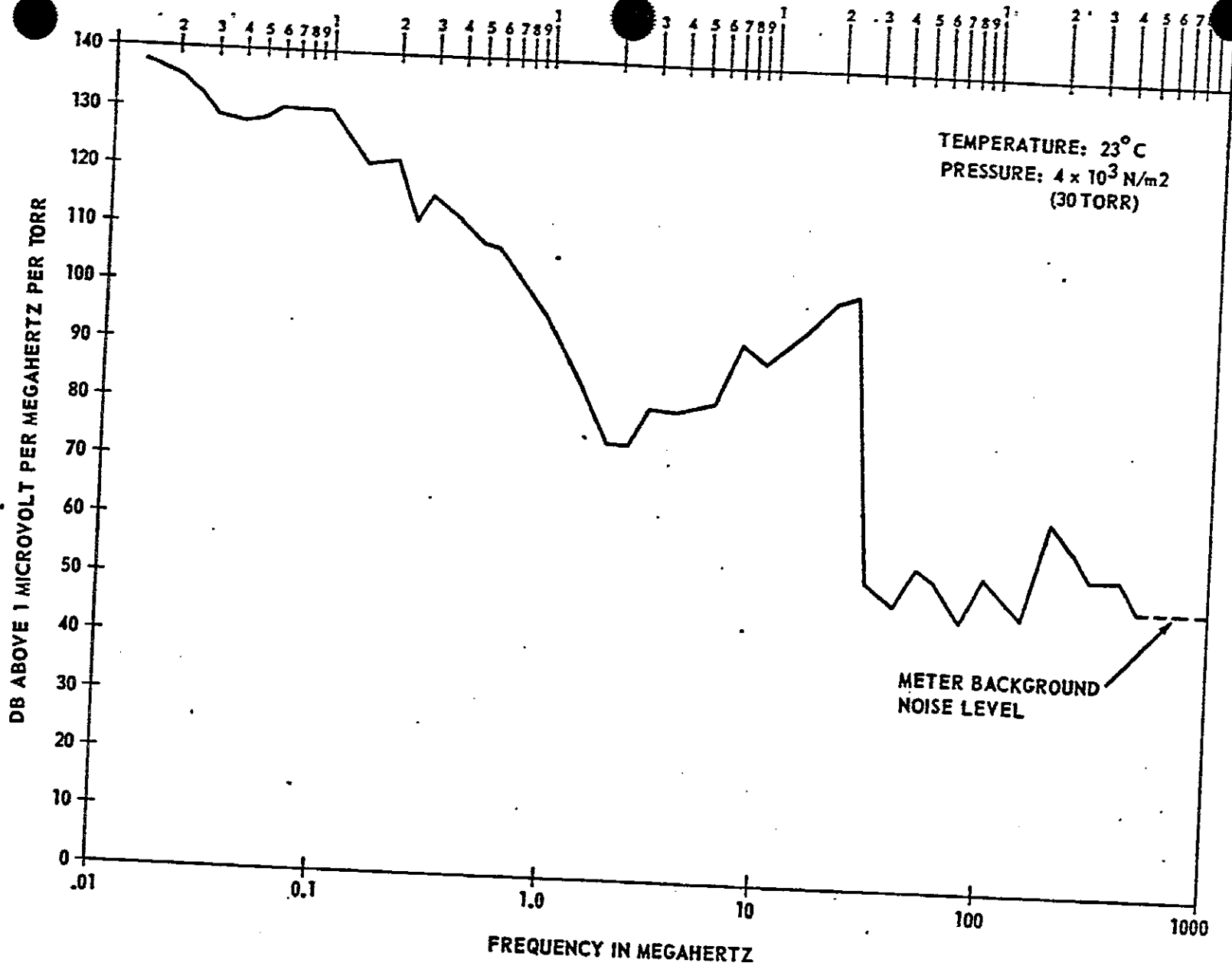

FIGURE 7.3.4.3 FREQUENCY SPECTRUM AT CORONA PRESSURE

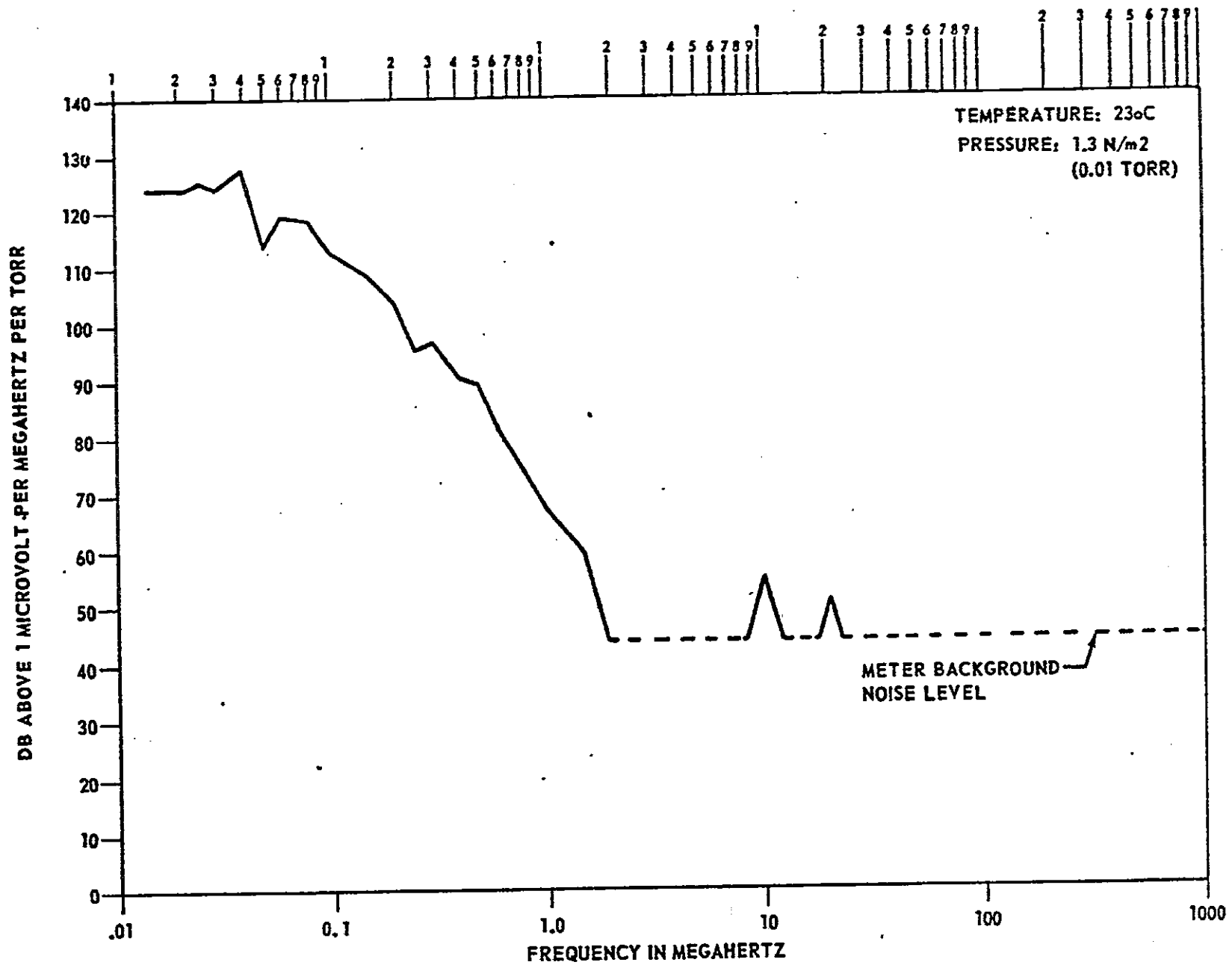

FIGURE 7.3.4.4 FREQUENCY SPECTRUM AT GLOW DISCHARGE PRESSURE

7.4 Facility and Environment - Thermal vacuum testing of spacecraft systems and space vehicles must be done in a thermally controlled vacuum chamber. It is a requirement that these chambers operate corona-free. Corona-free operation can be obtained by designing the chamber systems for corona-free operation and then checking the chamber system with a corona detection system. All the chamber equipment must be monitored for corona including the:

- a. Pressure gauges
- b. Heater panels
- c. Light sources
- d. Wiring cabling and connectors
- e. Test facility

The chamber systems and equipment can be evaluated with the same corona detection circuits and detectors as are used for spacecraft parts and circuits. Some requirements imposed upon the detection system are given below:

- a. The detection system must be capable of operating corona free at pressures less than  $4. \times 10^3 \text{ N/m}^2$  (30 torr).
- b. The corona detector must exhibit the following characteristics:
  1. Small size
  2. Simple circuitry
  3. Rapid response and readout
  4. Insensitivity to directional resolution capability
  5. Non-contaminating materials
  6. Corona-free operation

Some of the environmental parameters affecting corona are:

- a. Contamination
- b. Pressure
- c. Temperature
- d. Radiation
- e. Electromagnetic radiation
- f. Ionization

7.4.1 Contamination - Contamination can be in many forms such as foreign gasses, dust particles, oxides and salts, and out-gassing products. As stated in Paragraph 5.3, entrapped helium, argon, and neon effectively reduce the COV, when present. Therefore,



when a design is to be operated in an environment of pure or mixed gases, consultation with corona and materials specialists should take place prior to test implementation. This is due to the fact that some gases such as helium and hydrogen leak through ceramic/glass seals of pressurized units. Typical susceptible items are traveling wave tubes, magnetrons, and pressurized cases subjected to helium leak tests. These items must be purged free of the contaminating gas, if possible, or be reevaluated for corona susceptibility and new operating constraints added for these items, as appropriate.

Dust particle contamination can be a problem source within a device as it can be a local area of stress, develop tracking, and eventually act as a point electrode.

Oxides and salts deposited by handling during either the assembly, storage, transportation, or operating environment will degrade insulation materials, eventually to the point where they are ineffective. These same atmospheres will change the condition of electrodes (i.e., either configuration or composition) which, in turn, affects the minimum COV.

Normally, the gas pressure in a space simulating vacuum chamber and in deep space contains few charge carriers and the mean-free path far exceeds the gap distance of electrodes. Here "vacuum" is a good insulator. In most spacecraft, testing and spacecraft operations, this low gas pressure does not exist due to gas atom and charged particle contamination from the following sources:

- o Outgassing from nearby materials
- o Sublimation of nearby surfaces
- o Trapped air within the components
- o Gas-filled voids in insulation
- o Field-assisted or Schottky emissions
- o Thermionic emission from hot surfaces
- o Spacecraft leakage gases
- o Waste dumps

This contamination causes the interelectrode gap to approach the minimum COV from the high vacuum side of the Paschen Law curve. Most of the above factors are minimized during design and manufacturing control. However, it is imperative that the

test engineer and designer have a detailed specification defining the spacecraft pressure/temperature profile in the vicinity of the sensitive equipment for the mission to permit worst case design and test considerations which assure a corona-free system design.

7.4.2 Pressures - Figure 7.4.2.1, for spacecraft, generally shows how the gas pressure can be expected to vary with distance from the spacecraft. This does not include localized entrapped gas due to inadequate outgassing port area which is in addition to these considerations. It has also been observed that on manned missions, during extravehicular activity (EVA), the astronaut space suit outgassing raises pressures within a 1 meter radius to the  $1 \times 10^{-2}$  N/m<sup>2</sup> to 1.0 N/m<sup>2</sup> ( $10^{-4}$  to  $10^{-2}$  Torr) range. Thus, EVA in the vicinity of sensitive equipment must be considered in design and test.

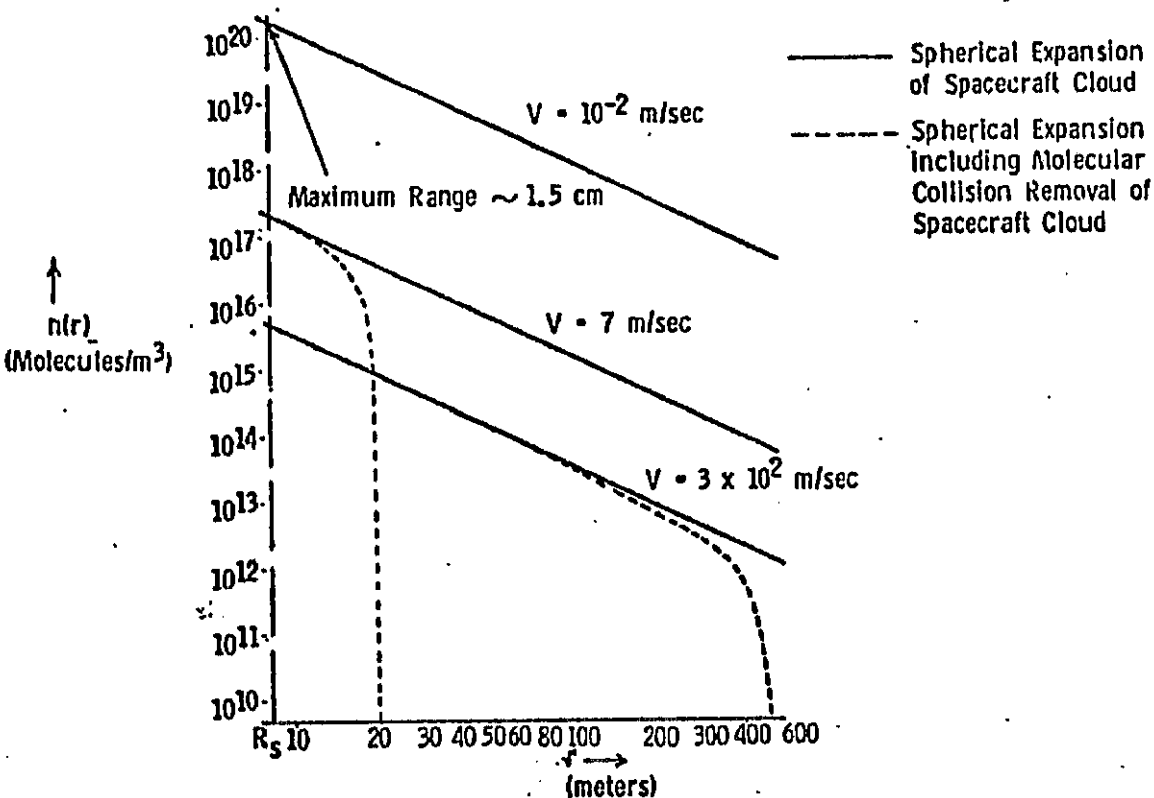

Figure 7.4.2.1. Typical Curve for Molecular Density Vs. Distance From the Center of a Spacecraft

7.4.3 Temperature - Periodic transient temperature changes and localized heating due to the proximity of heat generating equipment or parts will affect the corona onset voltage of some materials. For instance, some materials such as molybdenum and tungsten oxidize rapidly at high temperature and pressures greater than  $10^{-3}$  Torr. When this happens in vacuum the oxides will be deposited on surrounding cooler surfaces as long, thin crystals. These crystals tend to act as insulators at temperatures below  $100^{\circ}\text{C}$ . However, when they are reheated, the redeposited vapors have very low corona onset voltages which can effect low voltage circuits operations. Corona has been measured as low as 10 millivolts in a reheated contaminated atmosphere at pressures between 0.1 to  $10 \text{ N/m}^2$ .

7.4.4 Charged Particle Radiation - Another mechanism that affects COV at the critical pressure times spacing product are conducting plasmas such as those generated by an arc or solar/space charged particles and those within radioactive or nuclear fields. When a gamma emitting isotope is used as an ionizing material, it affects corona in three ways: first, it lowers the corona onset voltage slightly; second, it raises the intensity of the intermittent corona; and third, it may alter the mechanical and electrical properties of the insulation to make the material more or less corona resistant. However, irradiated polyethylene is an example of a material which is changed by radiation to be more corona resistant. Its increased corona resistance after irradiation results from an increase in ability to shrink and bond to itself to form a structure with fewer voids. Ultra-violet and infra-red radiation when intense and/or prolonged have degrading effects on materials.

The effects on equipment operation by radiation and charged particle fluence (discussed in Paragraph 5.4) are seldom considered during equipment qualification testing. They should be considered when the test article must be oriented toward the sun or when it can be affected by a radiation source.

7.4.5 Electromagnetic Radiation and Ionization - Electromagnetic radiation is recorded whenever a gaseous ionization or corona discharge occurs. These ionizations must be recorded by sensitive test equipment for they not only generate spurious noises within the equipment but accelerate the degradation of the nearby insulating materials.

7.5 Test Procedure - When performing a corona test, the following general rules apply:

- a. Properly locate and install the detector.
- b. Verify the instrumentation for elimination of crosstalk, interference, and groundloops.

- c. Verify that specimen handling has not produced scars, etching, discoloration; and its cleanliness, spacing, and alignment prior to installation into test chamber are proper. Changes to these conditions after the test will indicate problem areas.
- d. When a gas, other than air is used, always purge the chamber to be used by exhausting the chamber to 1.0 N/m<sup>2</sup> (0.01 torr) and filling to approximately 1 x 10<sup>5</sup> N/m<sup>2</sup> (760 torr) with the test gas at least three consecutive times. If external heating is required, activate the heater to evaporate contaminants from the heater elements, end bells of the chamber, and viewing ports.
- e. Calibrate the output recorders by operating the specimens in the chamber, preferably at a known critical COV pressure times spacing product.
- f. Pressurize the chamber to the correct test condition. The test conditions for simulating the expected operation conditions of temperature and pressure are calculated using the following equation:

$$P_t = P_o \frac{(273 + T_t)}{273 + T_o} V_c \quad \text{where } P_t = \text{test pressure}$$

$P_o = \text{operating pressure}$   
 $T_t = \text{test temperature}$   
 $T_o = \text{operating temperature}$   
 $V_c = \text{constant volume}$

Test specimen operation should be controlled by the design engineer.

- g. Determine the start of corona pulses by observing detection and recording equipment. Figure 7.3.4.1 shows the result of a corona discharge. The pulse repetition rate should be noted and recorded to permit termination of the test before permanent damage occurs.
- h. Periodically purge the test chamber to eliminate out-gassing products and to maintain the proper control of the test conditions.

**7.5.1 Altitude Chamber Testing** - At present, the most reliable tests are those which best simulate service conditions. For this reason, valid tests for the resistance of materials to long term breakdown processes such as corona erosion and treeing are particularly time consuming. Attempts to accelerate such tests are unreliable since materials do not respond linearly to changes in test severity. Hence, dependable information can often be

obtained only with tests extending over months or years. A word of caution is needed about the testing of sparking in an altitude chamber. Sparking may not occur in the chamber, but still occur in the equipment after launch. This is due to the fact that free electrons may be available in the equipment environment, but they may not be in the test chamber. To decrease the possibility of such a condition, a radioactive source such as polonium should be placed near the equipment under test in the space chamber. This will increase the possibility of electrons entering critical gap areas to simulate the space condition. Polonium is recommended because it is not so difficult to handle as other sources like Cobalt 60.

7.5.2 Life Testing - Accelerated life testing can be accomplished by operating at 20% overvoltage. This technique will shorten the test time by approximately two orders of magnitude as shown in Figure 6.8.2. However, it must be determined that the insulation system will operate corona free at both normal and overvoltage levels to assure that a contingency state does not exist. It is important to note that an insulation with a normal life capability of 10 years at a given voltage may have that capability reduced to one or two months if it is tested in an ionizing state.

It is important that components and single circuits be tested for a given time at overvoltage but not in an ionizing state. A suggested test voltage is 120 percent maximum operating voltage for 25% the anticipated life. The life expectancy should include hardware test and storage time.

Spacecraft equipment life cycling is very expensive and thus is usually limited to one or two test articles. It is imperative to life test critical components as near to the imposed operating atmosphere as is practical. For instance, determine by measurement in a large vacuum facility the actual pressure and temperature of the high voltage modules. This can be accomplished with the engineering development model. Then test the critical high voltage modules at maximum operating voltage, in vacuum, based on the following parameters:

- a. Corona detection readout should be monitored continuously by electronic means.
- b. Temperature cycling is required to determine the presence or absence of corona due to the thermal stressing of electrical components and insulation. Temperature cycling should be conducted from the minimum to the maximum temperature extremes specified for the equipment. A minimum of 5 such cycles are recommended. Each cycle should include "soak" time at each temperature extreme to ensure that the internal components and parts are thermally stabilized. These tests may be performed in either air or vacuum.

- c. If corona discharges increase with temperature increase, additional temperature cycles should be performed to determine whether the increased corona impulses were due to temperature or time.
- d. Pressure should be kept at the highest value for both temperature extremes or at the critical pressure shown by a Paschen Law curve if the high pressure exceeds  $1 \times 10^2$  N/m<sup>2</sup>.
- e. Upon completion of the temperature cycling, the high voltage should be turned off and on for five cycles at 5 min. intervals. The off time should be less than 15 seconds. During the power turn-on the corona detectors should be operating and recordings made of the system. If the magnitude and/or quantity of corona impulses increases for each on-off cycle, this is an indication the insulation is deteriorating and should be replaced.
- f. Life testing should follow the temperature cycling and should continue for at least 25% of the life expectancy of the equipment.

7.6 Corona Detection Circuits - The choice of circuit is determined as much by the electrical characteristics and mechanical layout of the device being tested as by the available detectors. This section of the document contains a survey of the various state-of-the-art detection and display devices and an assessment of the various detectors for spacecraft system applications.

7.6.1 Corona Detectors - Some detectors used to sense corona are: electronic, sonic, mechanical, chemical, and optical. Optical detection methods include visual, photographic, or use of photo-multipliers. In some cases discharge impingement sounds can be detected by sonic and mechanical devices. These sound waves can then be triangulated to locate the corona source. Chemical or ionization detectors can be used to record insulation outgassing products or newly generated gases created by the gaseous ionization. These systems each have limited application for corona detection.

Four approaches are available using electronic systems for corona detection. First, the corona onset voltage and corona extinction voltage can be measured. Second, the voltage waveform of the corona pulse can be observed to determine the corona magnitude and type. Third, the variation of the number and sequence of various pulse heights can be measured as a function of voltage and time. Fourth, the corona energy can be estimated from the pattern of the corona pulse waveforms. From

these electronic observations of corona, important insulation factors can be estimated, such as: voltage rating, quality of insulation, proper insulation design and an estimation of the life integrity for the insulation.

The use of a particular detector depends upon the application, inasmuch as no one detector can measure the phenomena in all environments and for all packaging concepts. Some of the useful applications and constraining limitations for the various types of detectors are shown in Table 7.6.1.1. The sensitivity and some general comments for specific detectors are shown in Table 7.6.1.2. The acceptable detectors that have been selected for corona and partial discharge measurement and evaluation are shown in Table 7.6.1.3.

Not enough is known about corona and its effects on materials to let the above electronic approaches provide the only criterion for insulation life assessment for a given applied voltage. Other tools such as high potential testing, impulse testing, dielectric stress, life testing, and materials electrical, chemical and mechanical characteristics are required for a full assessment. Indeed, corona testing sometimes completely fails to correlate with the observed life behavior. This may be due to either the difficulty in measuring corona or to failure mechanisms other than corona such as overstressing due to the induced environment.

**7.6.2 Detector Constraints** - Detectors must be placed near the test article in a position to detect but not disturb the electric fields and/or the operating characteristics of the test article and the test equipment. Likewise, a detector which must operate close to a high voltage circuit must be designed with sufficient sensitivity so it can be placed at a convenient distance from the test circuit to avoid shorting. In addition, the detector placement must not enhance voltage breakdown through the ground plane or detector.

Optical detectors must have sensitivities compatible with the amount of illumination they are to detect. If the test can be operated in a darkened environment, the optical detection of corona may be achieved where the detector is exposed to the circuit. Obviously, optical detection cannot be achieved in cases where the corona occurs in enclosed equipment, unless the optical detector is installed inside the package. In some tests, a solar simulator is used to illuminate the test article. In those cases, the optical detector will be ineffective as it will be unable to differentiate the light from the corona from that of the solar simulator. Even with the detector shielded the differentiation requirement is difficult to meet, except under specific instances where the detector can be directed toward a component or circuit which is

Table 7.6.1.1. Corona Detection Categories

<u>CATEGORY</u>	<u>TYPES</u>	<u>APPLICATION</u>	<u>COMMENTS</u>
Light Sensing	Solar cells	Measures light generated by the gaseous ionization between the open electrodes in a darkened chamber.	Sensitive to stray light.
	Photomultiplier		Cannot measure discharge in voids or enclosures.
	Cameras		
	Television Cameras		
	Solid-State Detectors		
Mechanical	Accelerometer	Measures mechanical vibration set up by gas pressure shock waves.	Massive discharges are required.
	Ultrasonic		Subject to external noise sources.
Electromagnetic Radiation	Voltage Standing Wave Ratio	Measures radio frequency emanations generated by the gaseous discharge.	Light, temperature and pressure insensitive.
	Antennas		
	Electrometer		Sensitive to outside radio frequency impulses.
	Sato Probe		Semi directional.
	Capacitor Probe		
Electronic Pickup	Capacitor Coupling	Measures the high frequency voltage and current impulses generated by the corona and partial discharges.	Attached to the corona sensitive circuit.
	Attached RF Coils		Light, temperature and pressure insensitive.
	Series Resistors		
Chemical Detectors	Mass Spectrometer	Measures generated ozone and out-gassing products.	Must be located close to the discharge.
			High voltage power supply required.
Scientific Instruments	Geiger Counter	Measures charged particles radiated by the corona discharge.	Located near the discharge.
	Curved Plate Analyzer		
	Cerenkov Detector		High Cost.
	Solid-State Detectors		Requires special modification and instrumentation.



Table 7.6.1.2. Corona Detector Characteristics

<u>TYPE</u>	<u>SENSITIVITY</u>	<u>COMMENTS</u>
<b>LIGHT SOURCES</b>		
Solar Cell	1.4 millivolt/milli lumen	Cooled surface required. Perpendicular to corona source.
Photomultiplier	1 volt/ $4 \times 10^{-4}$ lumen $1 \times 10^7$ gain-wideband	High voltage power supply required. Orientation to the corona source.
Television Camera	Low light level camera required. $1 \times 10^4$ gain	High voltage power supply required. Orientation to the corona source.
Still Camera	Very slow process	Not applicable.
<b>MECHANICAL</b>		
Accelerometer	90 Mv per 1.0G	Limited to 16 KHz. Attached to metal surface over corona discharge.
Ultrasonic	Depends upon the pressure	Requires pressures greater than $10^{-2}$ Torr. Very close to corona source.
<b>CHEMICAL DETECTOR</b>		
Mass Spectrometer	Measures gas discharge; very sensitive	High voltage power supply required. Outgassing products must be known.
<b>ELECTRONIC PICKUPS</b>		
Series Resistors	1 Mv/picocoulomb	Attached to the circuit.
Capacitors Coupling	0.1 Mv/picocoulomb	Attached to the circuit.
R.F. Coil	0.1 Mv/picocoulomb	Attached to insulated surface.

Table 7.6.1.2. Corona Detector Characteristics (Continued)

<u>TYPE</u>	<u>SENSITIVITY</u>	<u>COMMENTS</u>
<b>ELECTROMAGNETIC RADIATION</b>		
Voltage Standing Wave Ratio	0.1db difference	R.F. system only.
Loop Antenna	1.0 microvolt sensitivity	H-field measurement.
Monopole Antenna	1.0 microvolt sensitivity	E-field measurement.
Electrometer	0.1 millivolt/picocoulomb	Very close to discharge.
SATO Probe	0.1 millivolt/picocoulomb	Same as the electrometer.
Capacitor Probe	0.1 millivolt/picocoulomb	Same as the electrometer.
<b>SCIENTIFIC INSTRUMENTS</b>		
Geiger Counter	Measures charged particles	Attached or very close.
Curved Plate Analyzer	Measures charged particles	Attached.
Cerenkov Detector	Measures charged particles	Very close.
Solid State Detectors	0.1 KeV minimum	Measures X-ray and gamma ray
Lithium Drifted Germanium		emmanation.
Sodium Iodide Crystal (Cesium doped)		

Table 7.6.1.3. Recommended Detection Sensors

<u>TYPE</u>	<u>LIMITATIONS</u>
<b>CONNECTED</b>	Multiple Detectors Required
Coupling Capacitor	Parallel Connected
R.F. Coil	Surface Connected
Resistor	Series Connected
VSWR	Series Connected
<b>MOBILE</b>	Mobile Mechanism Required
Loop Antenna	Narrow Bandwidth
Monopole Antenna	Long Thin Antenna
Electrometer	Very Close To The Discharge
Ultrasonic	Soft Vacuum To One Atmosphere
<b>HIGH GAIN-LIGHT SENSITIVE</b>	High Voltage Circuitry Required.
Photomultiplier	Applicability
Television	Applicability
Low Light Level	

light shielded from the ambient illumination. Gaseous (ozone) detectors are required to have sensitivities sufficient to detect ozone in the test environments. This limits their usefulness since the environment must be oxygen bearing. For instance, nitrogen or other non-oxygen bearing atmospheres will not produce ozone. In addition, the detector must be placed near the test article so it can detect the small amount of ozone generated by the partial discharge. Electrostatic detection systems are required to be sufficiently sensitive to the partial discharge so that when it is placed a convenient distance from the test article, the detector circuitry and readout equipment can distinguish the corona signal from the noise background. Leads to the readout equipment should be kept short to prevent losses during data transmission.

**7.6.3 Standard Corona Detection Systems** - Most of the commercial state-of-the-art corona detection systems are designed and calibrated for testing high voltage transmission lines, electrical machinery and high voltage cables for the power companies or for the testing of dielectric gasses and insulation materials such as sheets and various shaped insulating blocks for the electrical and electronic industries. Most of the power equipment is designed to operate at either high pressure or at one Earth's atmosphere. The gas and insulation material evaluation equipment is designed to operate at ambient pressures and temperatures to 500°C. Most terrestrial detection systems use direct coupling. An example of a direct coupled detector is the addition of a resistor or coil in series with the corona sensitive element. Likewise a coupling capacitor soldered to the test article is directly coupled. An indirectly coupled sensor is a coil or capacitor plate placed near or on the corona sensitive element. Directly and indirectly coupled sensors are very sensitive and can be used for component and subsystem corona evaluation. Some modifications of the indirectly coupled units may be applicable for system tests.

Some directly coupled circuits are shown in Figures 7.6.3.1 through 7.6.3.4. One of the first standard corona detection circuits was developed by Quinn in 1940. Prior to that time corona was determined by measuring power system losses by power factor perturbations. Quinn's circuit was the first to use an oscilloscope for the display of corona signals. This circuit is shown in Figure 7.6.3.1. A direct coupled circuit used to measure gaseous breakdown and corona when testing components and evaluating gases is shown in Figure 7.6.3.2. Sheet and block insulating materials are tested by the circuit shown in Figure 7.6.3.3. A simple direct coupled circuit for detecting the corona onset voltage in long power cables is shown in Figure 7.6.3.4. A refined bridge circuit is shown in Figure 7.6.3.5. This circuit has greater sensitivity than the circuits shown in Figures

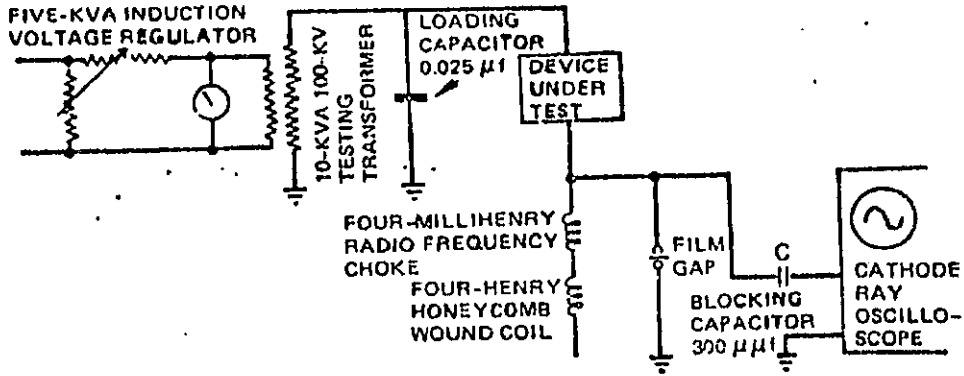

Figure 7.6.3.1 QUINN CORONA DETECTION CIRCUIT

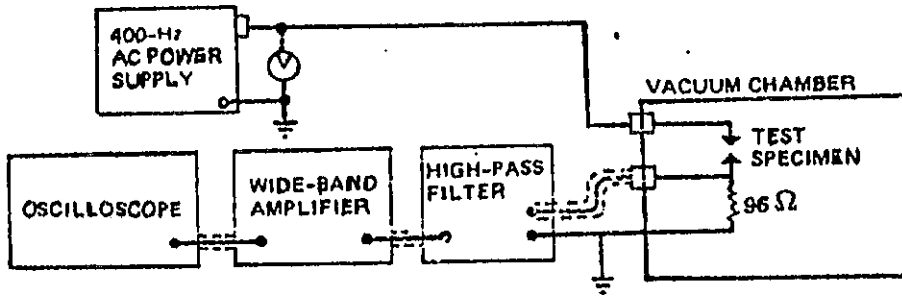

Figure 7.6.3.2 CORONA DETECTION CIRCUIT FOR GASEOUS BREAKDOWN AND CORONA (BOEING)

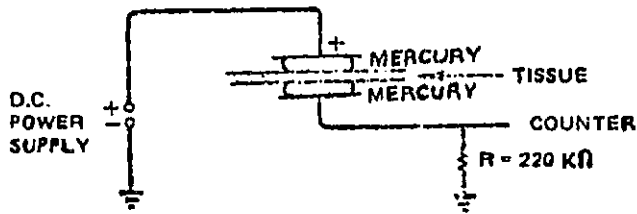

Figure -7.6.3.3 MATERIALS EVALUATION TEST CIRCUIT

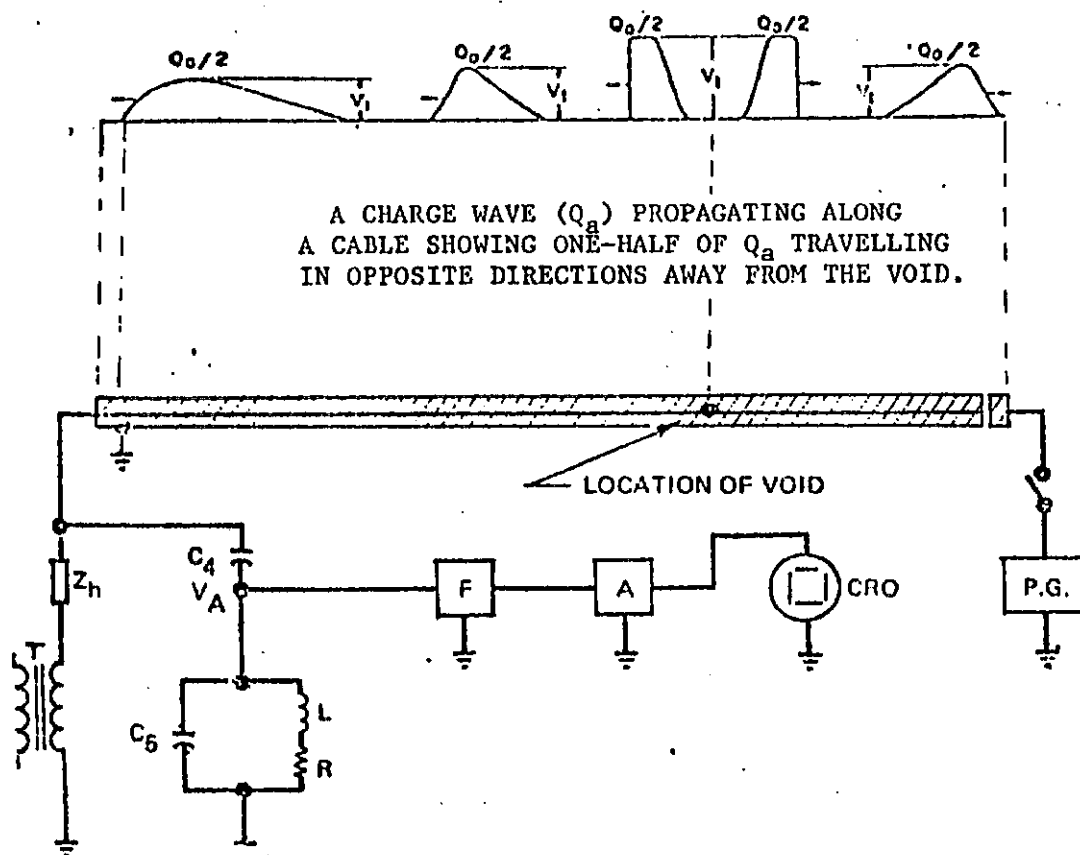

Figure 7.6.3.4 CIRCUIT DIAGRAM OF DISCHARGE DETECTOR WITH A LONG CABLE SAMPLE

- T - HIGH VOLTAGE TRANSFORMER
- $Z_h$  - SEPARATING IMPEDANCE (MINIMUM INDUCTANCE 0.1 H)
- $C_4$  - COUPLING CAPACITANCE (3,000 pF)
- $C_6$  - LOW VOLTAGE CAPACITANCE (3,000 pF)
- L - INDUCTANCE OF THE COIL (6 mH)
- R - RESISTANCE OF THE COIL (50 OHMS)
- F - FILTER (PASS BAND 25 TO 35 KC/S)
- A - AMPLIFIER
- CRO - OSCILLOSCOPE
- P.G. - PULSE GENERATOR (PULSE DURATION 15 NANoseconds)

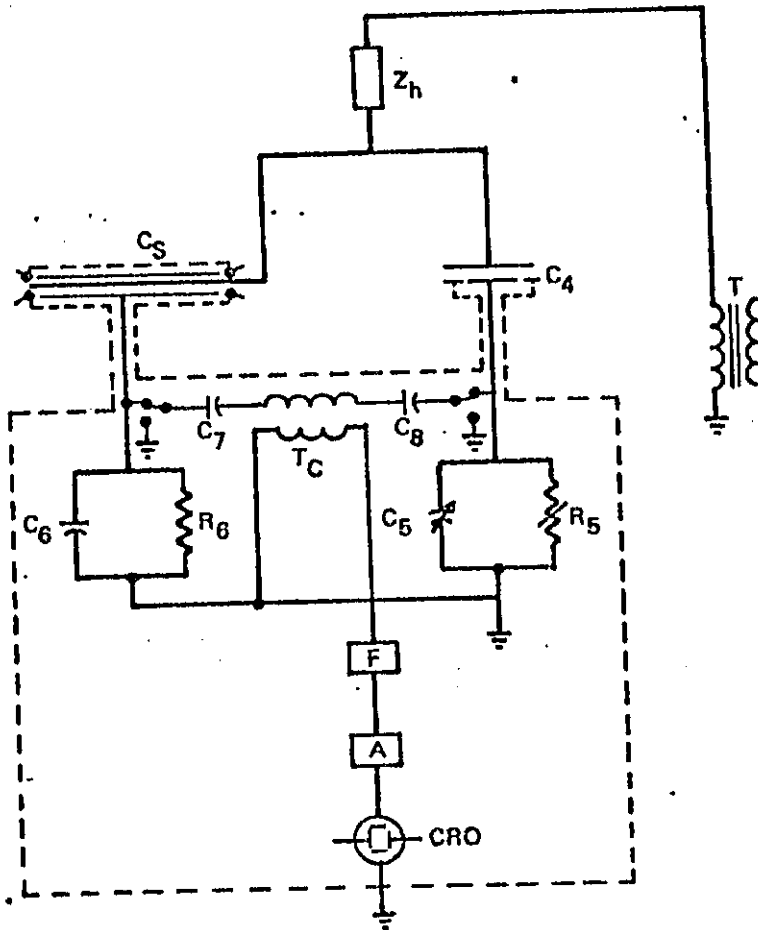

Figure 7.6.3.5 BRIDGE DETECTOR CIRCUIT

- T - HIGH VOLTAGE TRANSFORMER
- $Z_h$  - SEPARATING IMPEDANCE (MINIMUM INDUCTANCE 0.1 H)
- $C_s$  - CAPACITANCE OF CABLE
- $C_4$  - COUPLING CAPACITANCE (1,500 TO 3,000 pF)
- $C_5$  - VARIABLE LOW VOLTAGE CAPACITANCE (0 TO 10,000 pF)
- $C_6$  - LOW VOLTAGE CAPACITANCE (1,000 TO 3,000 pF)
- $C_7, C_8$  - FILTERING CAPACITANCE (1,000 pF)
- $R_5$  - VARIABLE RESISTANCE (0 TO 100,000 OHMS)
- $R_6$  - RESISTANCE (200 TO 1,000 OHMS)
- $T_c$  - COUPLING TRANSFORMER (INDUCTANCE OF WHICH IS CHOSEN SO TO OBTAIN OSCILLATION FREQUENCY 15 TO 30 KC/S)
- F - BAND PASS FILTER (PASS BAND 10 TO 50 KC/S)
- A - AMPLIFIER
- CRO - OSCILLOSCOPE

7.6.3.1 through 7.6.3.4, and is not as susceptible to extraneous noise. Recently, pulse-height analyzer circuits have been added to the various corona detection circuits. Pulse-height analyzers are very sensitive and provide a recording of the corona tests. The recorded data can be used during analyses for the evaluation of corona erosion of the insulation materials. A typical corona circuit for a pulse-height analyzer is shown in Figure 7.6.3.6. The circuit connection and corona detection network used for evaluation of spacecraft components and systems at the Jet Propulsion Laboratory are shown in Figures 7.6.3.7 and 7.6.3.8; these circuits are directly coupled and are used for the detection of corona in simple circuits, parts, and test cells. In addition, they can be used to analyze the probability of corona on a specific circuit after it has been isolated by a nondirect-coupled circuit. The circuits recommended for spacecraft; part, circuit, and system evaluation, are shown in Figures 7.6.3.2, 7.6.3.3, 7.6.3.5, 7.6.3.6, 7.6.3.7, and 7.6.3.8.

7.7 Data Analysis - When corona is detected during a test the test should be immediately terminated before permanent damage to the test item can occur. The test article should be de-energized and a failure analysis performed prior to retest to permit the proper repair of the defective area.

Post test inspection of the test article should include:

- a. Observation of the equipment case or enclosure in the vicinity of high voltage circuits and wiring, for metal migration, discoloration, or burns.
- b. Observation of high voltage insulation for crystal growth and/or punctures, burns, or discoloration. Normally, a magnifying aid of 20 diopters power is sufficient to reveal these abnormalities.
- c. Observation of high voltage wire and circuitry insulation for sputtered metal which appears as a dark grey film, when it exists.
- d. Observation of potting and conformal coating for cracks, crazing, and treeing. When these defects occur over a component, inspect the component as it too may have a similar defect.
- e. Observation of seals about enclosures for micro-cracks, separation of sealant, poor application of sealant or loose fitting parts.



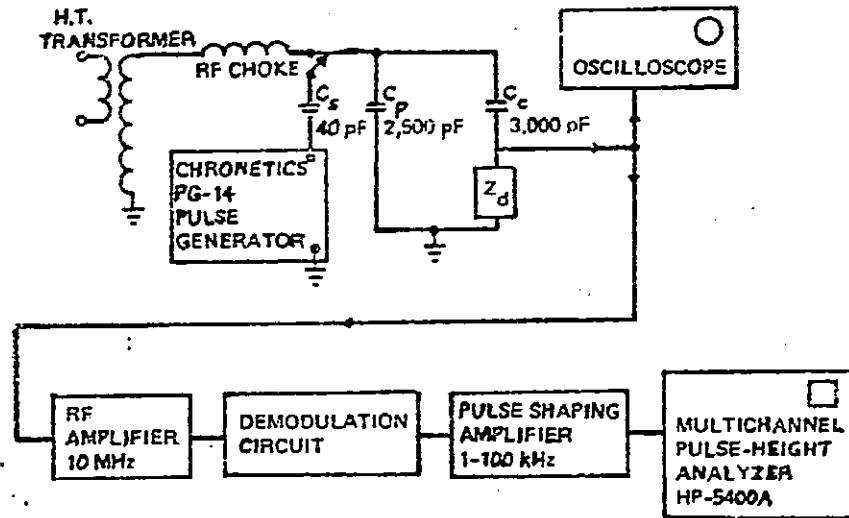
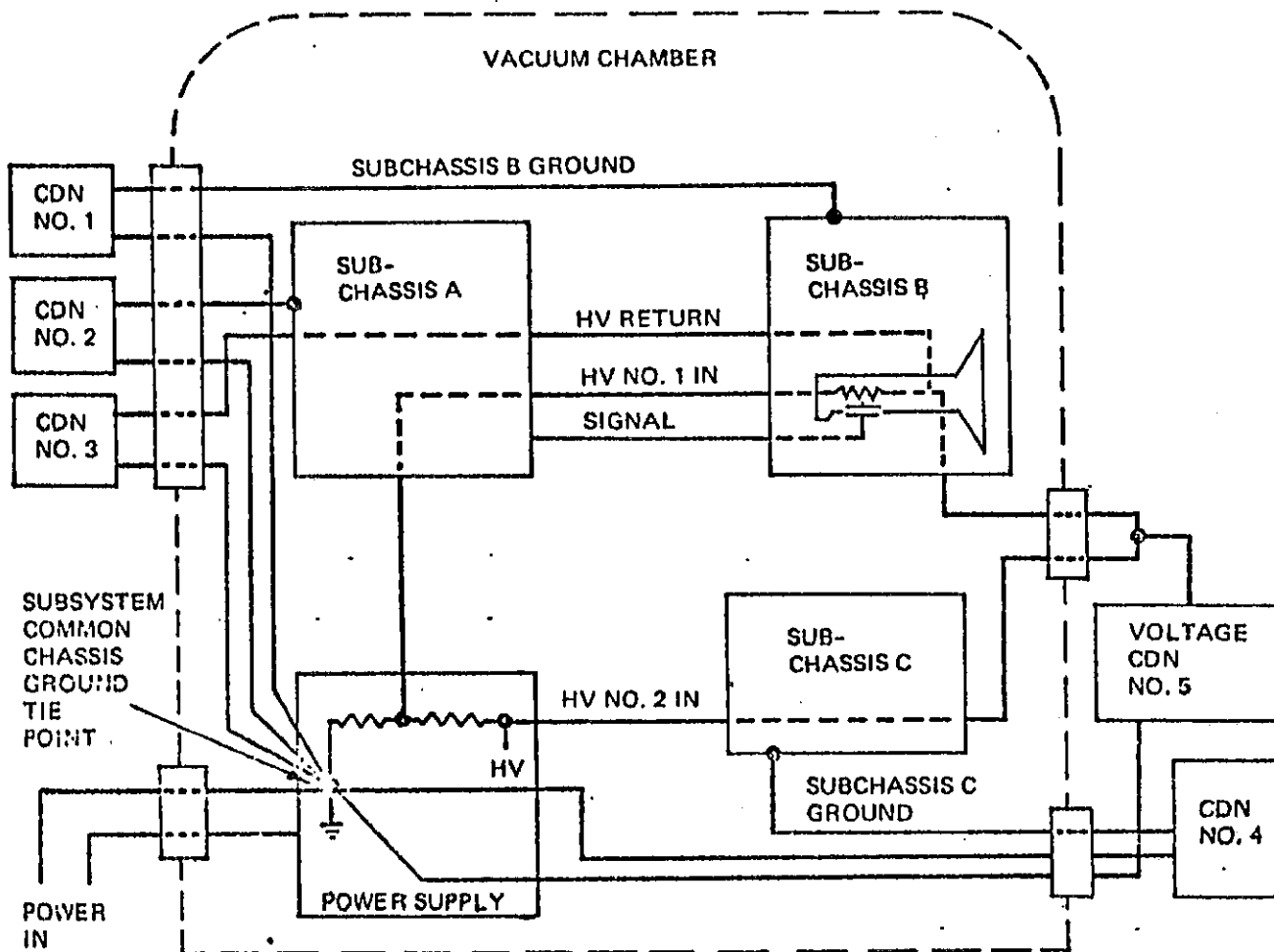
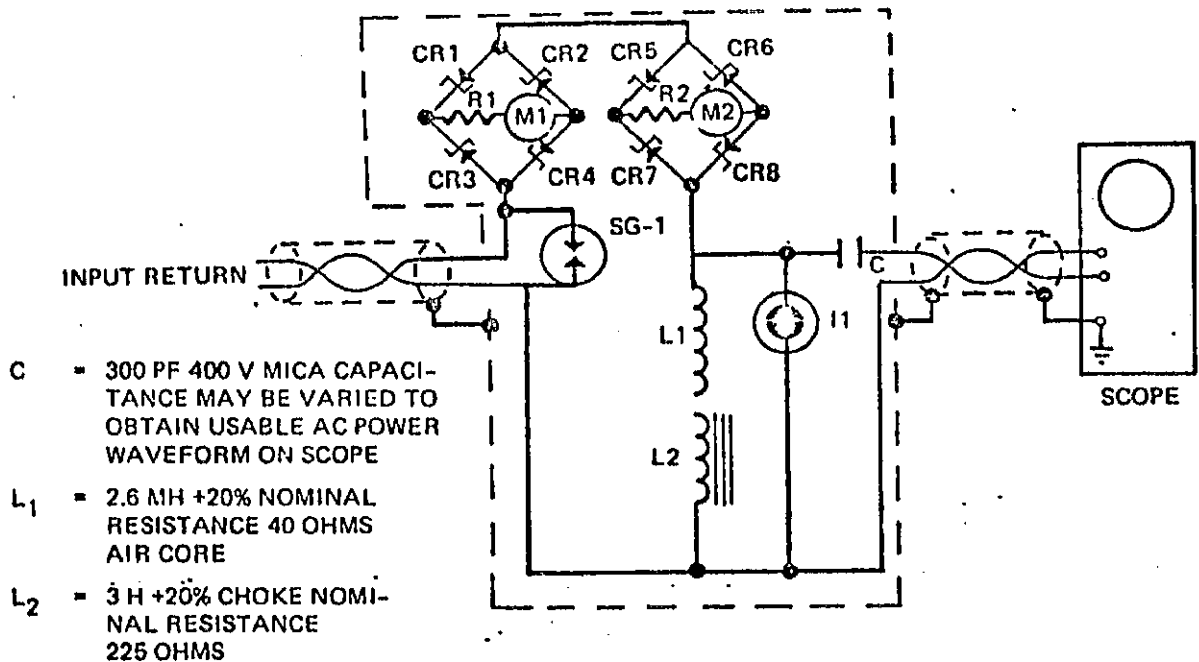

Figure 7.6.3.6 CIRCUIT FOR CORONA PULSE-HEIGHT DISTRIBUTION ANALYSIS WITH VARIABLE -RISE-TIME PULSE CALIBRATOR



## NOTES:

1. CDN = CORONA DETECTION NETWORK (JPL)
2. CDN 1, 2, 4 MONITOR POSSIBLE CORONA CURRENTS FROM HIGH VOLTAGE LINES TO CORRESPONDING SUBCHASSIS. CDN 3 MONITORS POSSIBLE CORONA CURRENTS BETWEEN HV NO. 1 CONDUCTOR AND RETURN
3. IN CASES WHERE IMPEDANCE IN RETURN OR CDN ADVERSELY AFFECTS SUBSYSTEM OPERATION, VOLTAGE TYPE (CDN NO. 5) MAY BE CONNECTED TO HV LEAD (NO. 2) AS SHOWN
4. ONE CDN WITH GROUNDING SWITCH COULD BE USED IN PLACE OF CDN 1, 2, 3, 4



**SG-1** SIEMENS PROTECTIVE GAP

**I<sub>1</sub>** = NE-2 NEON -- OPEN CIRCUIT PROTECTION .

**CR1 - CR8** - 10V ZENER DIODES

**M-1** - 0 - 5 MICROAMMETER (CORONA)

**M-2** - 0 - 1 MILLIAMMETER (ARC)

**R-1** - MICROAMP CALIBRATION RESISTOR

**R-2** - MILLIAMP CALIBRATION RESISTOR

SCOPE-AC CORONA INDICATION



SCOPE-DC CORONA INDICATION

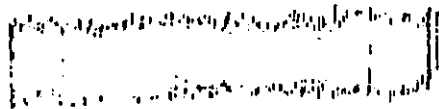

- NOTES:**
1. IF ELECTRODE CONFIGURATION IS UNSYMMETRICAL, CORONA BURSTS ON ONE POLARITY OF SUPPLY FREQUENCY WAVEFORM MAY BE ABSENT
  2. ABRUPT BREAKS IN SCOPE TRACE OR BURST AMPLITUDES  $> 0.5$  VOLT PEAK-TO-PEAK INDICATE ARCING, RATHER THAN CORONA
  3. SCOPE SENSITIVITY 10 MV/CM

Figure 7.6.3.8 CORONA DETECTION NETWORK SCHEMATIC (JPL)

- f. Observation of insulated protruding parts (such as; turret terminals, high voltage capacitor leads, and transformer terminals) to assure that there is adequate insulation. When a coating has been applied, breakdown can result where the height of all protruding electrodes are not uniform. This is due to the fact that the higher electrodes will have the thinnest coating which makes it more corona-susceptible than the other insulated areas.
- g. Observation of ceramic or glass parts adjacent to parts that may impact them causing cracks, chips, or cutting of softer insulation materials, as well as exposure to a foreign atmosphere.

7.7.1 Temperature Cycling - An example of temperature effects on corona discharges is shown in Figure 7.7.1.1. A curve plate analyzer operating at -4000 volts (DC) was tested at its lowest operating temperature (0°C) for 770 minutes. During this period the random ion counts were minimal and attributed to: spurious noises, atmospheric effects, and instrumentation. When the temperature was raised to 50°C (at a rate of 50°C/hour) the ion counts started to increase above the threshold noise level. By the time the instrument reached 70°C the instrument turned off due to excessive current. When the temperature was decreased to 40°C the noise level returned to threshold values. Further testing of this instrument was unnecessary because it could not meet the specified design requirements. The example is used to demonstrate the noise increase with temperature.

The time lag for temperature cycling is demonstrated by the second temperature cycle starting at 40°C and 920 minutes. Note that the temperature is almost at the critical point at 40°C. Thus the ion counts increased immediately as the temperature was raised. These ion counts were attributed to faulty insulation and outgassing during a failure analysis examination.

7.7.2 Switching - During switching the electrical insulation is stressed similar to that of a quarter cycle of an alternating voltage. Consequently voids, cracks, and flaws will become electrically stressed and be subject to partial discharges. An example of a switching transient is shown in Figure 7.7.2.1. This example shows the output of another curved plate analyzer; not one of the same design as demonstrated in Figure 7.7.1.1. The instant application of voltage is associated with large ion counts. These ion counts decrease numerically to steady-state noise level in approximately five seconds. The subsequent ion counts are from test-generated noises and insulation degradation.

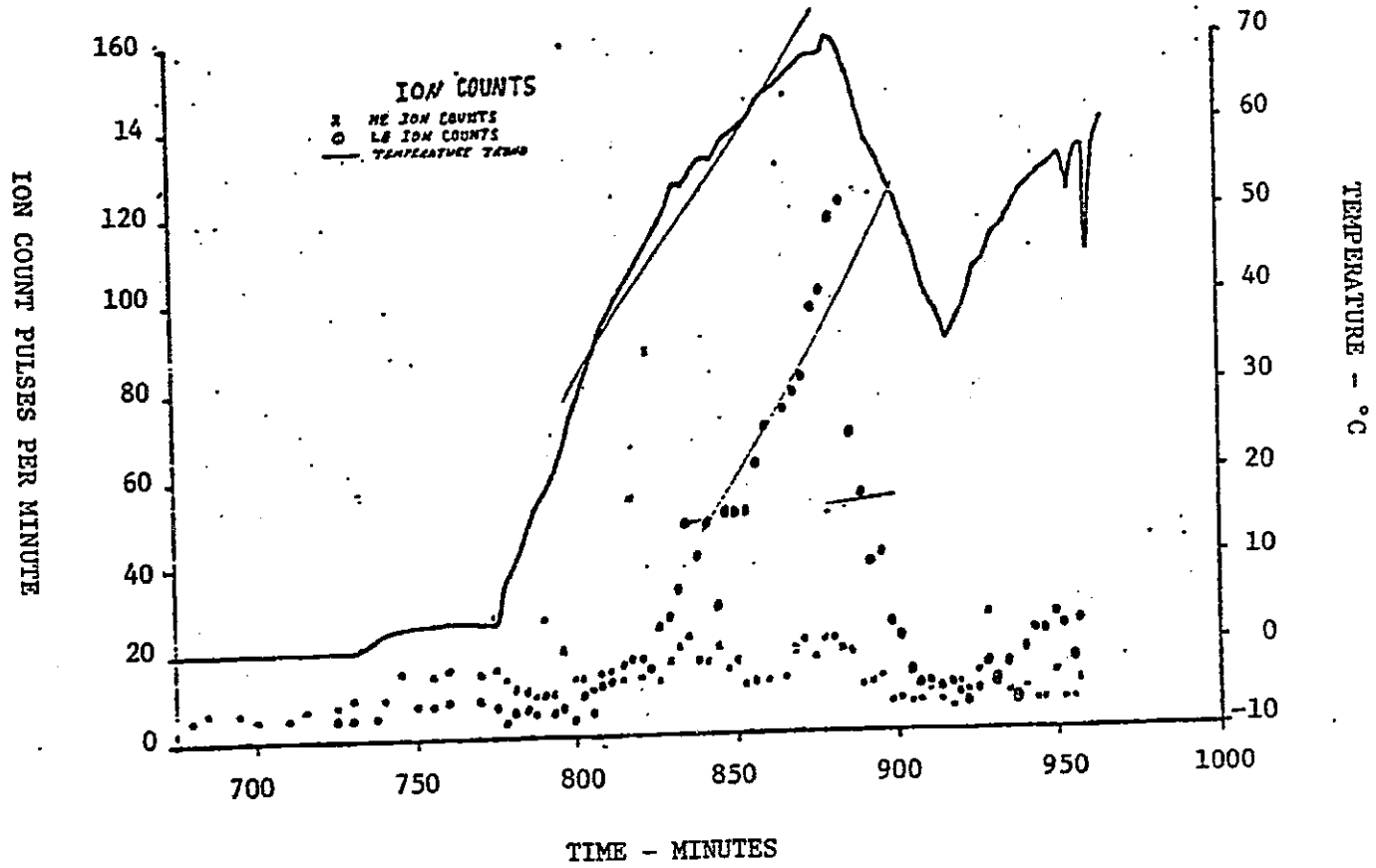

Figure 7.7.1.1. Typical Ion Count Versus Time Data Based on Increasing Temperature of the Test Sample (Corona Pulses are Shown Lagging Temperature)

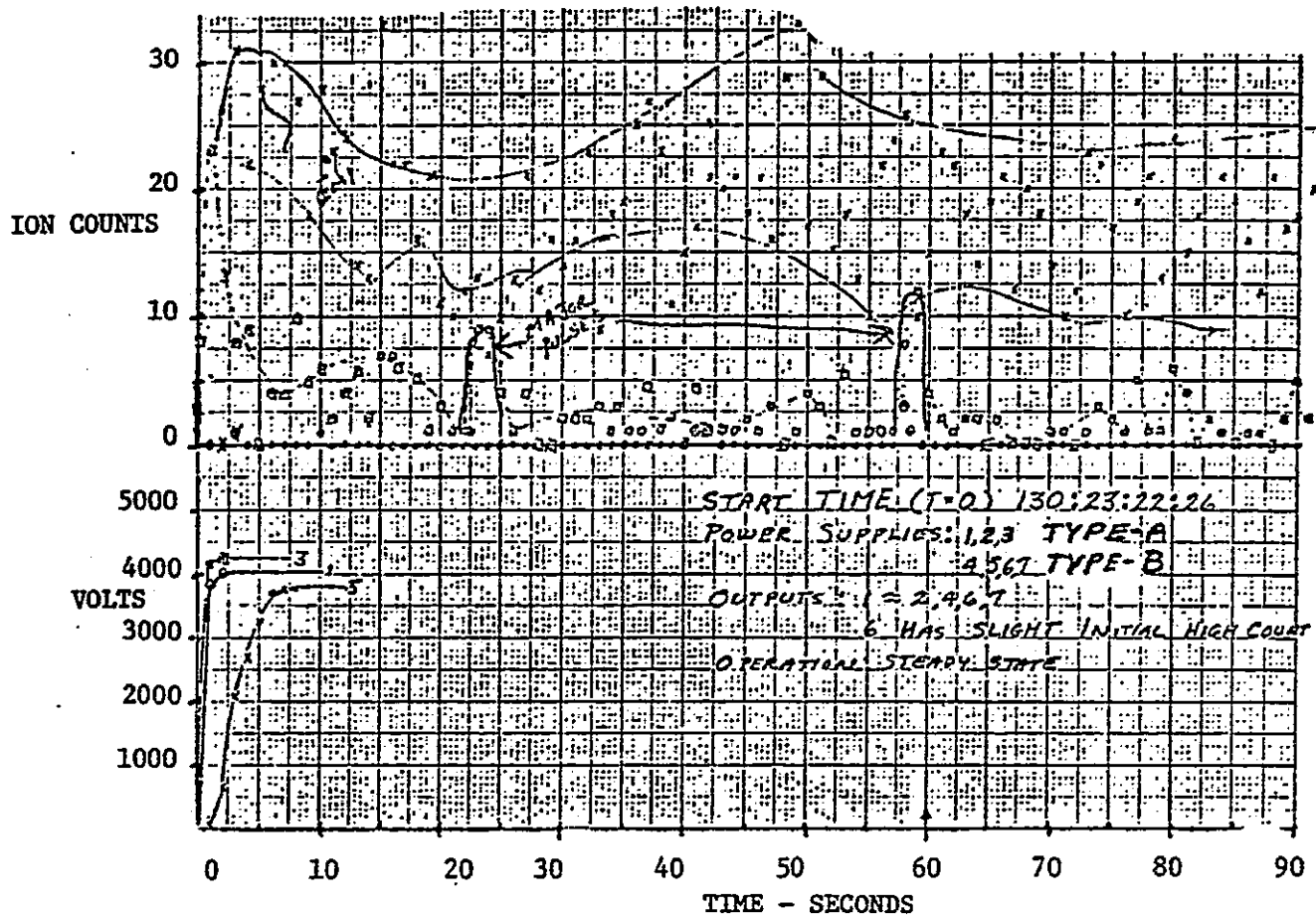

Figure 7.7.2.1. Typical Corona Test Data Showing Major and Minor Corona Pulses

When the insulation is stressed many times at a given temperature (preferably the maximum operating temperature) the ion counts will either remain approximately the same as the initial turn-on or will increase. If they should increase in magnitude and time, this is an indication of insulation degradation. At least 25 turn-on cycles are normally required to show this effect.

7.7.3 Prototype Tests - During voltage stress and life testing of prototype equipment, groups of partial discharges are to be watched. In Figure 7.7.2.1, two major pulses are shown, one at 23 seconds and another at 57 seconds. If these major pulses do not increase in magnitude, quantity or duration or if they die out completely the insulation system is properly designed and of flight quality. However, if the average time between pulses shortens and the pulses tend to increase in magnitude, that is a positive indication of corona and treeing within the insulation. At this time the test should be terminated. The circuit layout diagrams must be analyzed to assess the most probable locations of high fields and those areas will require thorough detailed analysis and microscopic investigation to verify the failure mode. This analysis will offer the high-voltage design engineer an opportunity to design the flight equipment for long life in the improved environment.

When the insulation is stressed many times at a given temperature (preferably the maximum operating temperature) the ion counts will either remain approximately the same as the initial turn-on or will increase. If they should increase in magnitude and time, this is an indication of insulation degradation. At least 25 turn-on cycles are normally required to show this effect.

7.7.3 Prototype Tests - During voltage stress and life testing of prototype equipment, groups of partial discharges are to be watched. In Figure 7.7.2.1, two major pulses are shown, one at 23 seconds and another at 57 seconds. If these major pulses do not increase in magnitude, quantity or duration or if they die out completely the insulation system is properly designed and of flight quality. However, if the average time between pulses shortens and the pulses tend to increase in magnitude, that is a positive indication of corona and treeing within the insulation. At this time the test should be terminated. The circuit layout diagrams must be analyzed to assess the most probable locations of high fields and those areas will require thorough detailed analysis and microscopic investigation to verify the failure mode. This analysis will offer the high-voltage design engineer an opportunity to design the flight equipment for long life in the improved environment.



PACKAGE NO. 10443R

DOCUMENTATION RELEASE LIST  
GEORGE C. MARSHALL SPACE FLIGHT CENTERMSFC CODE IDENT 14981/339B2  
ISSUE DATE FEB 22 2007

PAGE 1

C H	DOCUMENT NUMBER	DRL DRL DSH REV	TITLE	CCBD NO.	PCN	PC	EFFECTIVITY
*	MSFC-STD-531	202 -	HIGH VOLTAGE DESIGN CRITERIA	000-00-0000	0000000	M	NONE
CHG NO.	CHG REV	CHG NOTICE	RESPONSIBLE ENGINEER	RESPONSIBLE ORGANIZATION	ACTION DATE	DESCRIPTION	
			R. WHITE	EB34	02/03/94	BASELINE RELEASE 12/13/78	
*	1	DCN000	EUGENA GOGGANS	EO03	02/22/07	DOCUMENT RELEASED THRU PDS. NO LONGER TRACKED IN ICMS.	

CHECKER

N/A  
02/15/07

(FINAL)

PACKAGE NO: 10443R

PROGRAM/PROJECT: MULTI

LAST UPDATED: 02/22/07

NOMENCLATURE: MSFC-STD- GOING TO NONE EFFECTIVITY

ECR NO:	PCN:	CCBD NO:	DATE PREPARED:
EO03-0000	0000000	000-00-0000 SB3-00-0000	02/22/07

DWG SIZE	DRAWING NUMBER	DWG REV	EPL/DRL/DDS NUMBER	DWG REV	EPL DSH	EPL REV	EO DASH NUMBER	EO REV	PART NUMBER
			MSFC-HDBK-1453		202	-			
			MSFC-HDBK-1674		202	-			
			MSFC-HDBK-2221		203	-			
			MSFC-HDBK-505		202	-			
			MSFC-HDBK-670		202	-			
			MSFC-MNL-1951		209	-			
			MSFC-PROC-1301		202	-			
			MSFC-PROC-1721		202	-			
			MSFC-PROC-1831		202	-			
			MSFC-PROC-1832		202	-			
			MSFC-PROC-404		202	-			
			MSFC-PROC-547		202	-			
			MSFC-QPL-1918		204	-			
			MSFC-RQMT-1282		202	-			
			MSFC-SPEC-1198		202	-			
			MSFC-SPEC-1238		202	-			
			MSFC-SPEC-1443		202	-			
			MSFC-SPEC-164		202	-			
			MSFC-SPEC-1870		202	-			
			MSFC-SPEC-1918		203	-			
			MSFC-SPEC-1919		206	-			
			MSFC-SPEC-2083		202	-			
			MSFC-SPEC-2223		202	-			
			MSFC-SPEC-2489		206	-			
			MSFC-SPEC-2490		205	-			
			MSFC-SPEC-2491		203	-			
			MSFC-SPEC-2492		203	-			
			MSFC-SPEC-2497		211	-			
			MSFC-SPEC-250		202	-			
			MSFC-SPEC-445		202	-			
			MSFC-SPEC-504		202	-			
			MSFC-SPEC-521		202	-			
			MSFC-SPEC-548		202	-			
			MSFC-SPEC-560		202	-			
			MSFC-SPEC-626		202	-			
			MSFC-SPEC-684		202	-			
			MSFC-SPEC-708		202	-			
			MSFC-SPEC-766		202	-			
			MSFC-STD-1249		202	-			
			MSFC-STD-1800		202	-			
			MSFC-STD-246		202	-			
			MSFC-STD-2594		203	-			

PACKAGE NO: 10443R

DWG SIZE	DRAWING NUMBER	DWG REV	EPL/DRL/DDS NUMBER	DWG REV	EPL DSH	EPL REV	EO DASH NUMBER	EO REV	PART NUMBER
			MSFC-STD-2903		202	-			
			MSFC-STD-2904		202	-			
			MSFC-STD-2905		202	-			
			MSFC-STD-2906		202	-			
			MSFC-STD-2907		202	-			
			MSFC-STD-366		202	-			
			MSFC-STD-383		202	-			
			MSFC-STD-486		202	-			
			MSFC-STD-506		203	-			
			MSFC-STD-531		202	-			
			MSFC-STD-557		202	-			
			MSFC-STD-561		203	-			
			MSFC-STD-781		202	-			

SUBMITTED BY ENGINEERING AREA:	BASIC	CHANGE	PARTIAL	COMPLETE	CLOSES	ACTION
EO03		X		X		EO03

PREPARED BY:  
EUGENA GOGGANS  
12/19/06

SUBMITTED BY:

CONCURRENCE:

TRANSMITTAL DATES  
TO RELEASE DESK 02/22/07 10:00  
TO MSFC DOC REP 02/22/07 00:00

REMARKS:

2007 FEB 22 AM 11:22

# MSFC DOCUMENTATION REPOSITORY - DOCUMENT INPUT RECORD

## I. GENERAL INFORMATION

1. APPROVED PROJECT: Space Environments and Effects (SEE) Program	2. DOCUMENT/ DRAWING NUMBER: MSFC-STD-531	3. CONTROL NUMBER:	4. RELEASE DATE: 01/01/1978	5. SUBMITTAL DATE: 8/13/03
6. DOCUMENT/DRAWING TITLE: High Voltage Design Criteria			7. REPORT TYPE: Standard	
8. CONTRACT NUMBER / PERFORMING ACTIVITY:	9. DRD NUMBER:	10. DPD / DRL / IDRD NUMBER:		
11. DISPOSITION AUTHORITY (Check One): <input checked="" type="checkbox"/> Official Record - NRRS 8/12/A <input checked="" type="checkbox"/> Reference Copy - NRRS 8/5/A/3 (destroy when no longer needed)		12. SUBMITTAL AUTHORITY:	13. RELEASING AUTHORITY: <i>William J. Kaufman, Jr.</i> William J. Kaufman, Jr.	
14. SPECIAL INSTRUCTIONS:				
15. CONTRACTOR/SUBMITTING ORGANIZATION, ADDRESS AND PHONE NUMBER:			16. ORIGINATING NASA CENTER: Marshall Space Flight Center	
			17. OFFICE OF PRIMARY RESPONSIBILITY: Space Environments and Effects (SEE) Program ED03 Jody Minor/4-4041	
18. PROGRAMMATIC CODE (5 DIGITS): 755-11			19. NUMBER OF PAGES: 120	

## II. ENGINEERING DRAWINGS

20. REVISION:	21. ENGINEERING ORDER:	22. PARTS LIST:	23. CCBD:
---------------	------------------------	-----------------	-----------

## III. REPORTS, SPECIFICATIONS, ETC.

24. REVISION:	25. CHANGE:	26. VOLUME:	27. BOOK:	28. PART:	29. SECTION:
30. ISSUE:	31. ANNEX:	32. SCN:	33. DCN:	34. AMENDMENT:	
35. APPENDIX:	36. ADDENDUM:	37. CCBD:	38. CODE ID:	39. IRN:	

## IV. EXPORT AND DISTRIBUTION RESTRICTIONS

- |   |  |
|---|--|
| <input type="checkbox"/> Privacy Act (see MWI 1382.1) | <input type="checkbox"/> EAR (see MPG 2220.1)  |
| <input type="checkbox"/> Proprietary (see MPD 2210.1) | <input type="checkbox"/> Other ACI (see NPG 1620.1 and MPG 1600.1)   |
| <input type="checkbox"/> Patent (see MPG 2220.1)      | <input checked="" type="checkbox"/> No statutory or institutional restrictions applicable -- material may be electronically distributed to user in the NASA domain |
| <input type="checkbox"/> ITAR (see MPG 2220.1)        |  |

## V. ORIGINATING ORGANIZATION APPROVAL

40. ORG. CODE: ED03	41. PHONE NUMBER: (256) 544-4041	42. NAME: Jody L. Minor	43. SIGNATURE/DATE: <i>Jody L. Minor</i> 8/13/03
------------------------	-------------------------------------	----------------------------	---

## VI. TO BE COMPLETED BY MSFC DOCUMENTATION REPOSITORY

44. RECEIVED BY: <i>Jammy Wise</i>	45. DATE RECEIVED: 10-15-03	46. WORK ORDER:
---------------------------------------	--------------------------------	-----------------