

NOTICE - When Government drawings, specifications, or other data are used for any purpose other than in connection with a definitely related Government procurement operation, the United States Government thereby incurs no responsibility nor obligation whatsoever; and the fact that the Government may have furnished, furnished, or in any way supplied the said drawings, specifications or other data is not to be regarded by implication or otherwise as in any manner licensing the holder or any other person or corporation, or conveying any rights or permission to manufacture, use, or sell any patented invention that may in any way be related thereto.

APPLICATION		PART No.	M F	REVISIONS			
NEXT ASSY	USED ON			SYM	DESCRIPTION	DATE	APPROVAL
				E	REVISED ALL SHEETS	11/13/84	WRS
				F	REVISED SHT. 1, REVISED RETYPED AND RENUMBERED SHTS 2-129, ADDED 130-162	5/30/90	MPH, JEC, RDH, RLC, WRS, GOL
				G	REVISED SHEET 1, REVISED & RETYPED SHTS 2-162, ADDED SHT 163, SWD 900741	2/24/92	RLC, MPH
				H	REVISED SHEET 1, REVISED SHEETS 107-113 TO INCLUDE FABRICATION AND INSTALLATION OF TYPE I CHASSIS MANIFOLDS	11/6/92	TN
				J	GENERAL REVISION, REFERENCE PAGE 2 FOR DETAILED DESCRIPTION, RETYPED SHEET 1, ADDED SHEETS 164-174	6/16/93	RDH <i>TN</i> <i>ERK</i>

UNLESS OTHERWISE SPECIFIED		ORIGINAL DATE OF DRAWING	4/12/73	RETEST AND REFURBISHMENT OF COMPRESSED GAS TRAILERS AND MOVABLE STORAGE UNITS, STANDARD FOR		JOHN F. KENNEDY SPACE CENTER, NASA  KENNEDY SPACE CENTER, FLORIDA	
DIMENSIONS ARE IN INCHES TOLERANCES ON:		DRAWN	CHECK				
FRACTIONS DECIMALS ANGLES		TRACED	CHECKED				
MATERIAL		ENGINEER	ENGINEER				
HEAT TREATMENT		SUBMITTED 11/13/84		SCALE		DWG SIZE	KSC-SO-S-9
FINAL PROTECTIVE FINISH		APPROVED 11/13/84		UNIT WT		A	
		EUGENE SCHUMANN				SHEET 1 OF 174	
		W. SANDERS					

## RECORD OF REVISIONS/CHANGES

REV LTR	CHANGE NO.	DESCRIPTION	DATE
J		<b>GENERAL REVISION</b> <b>MAJOR CHANGES INCLUDE THE FOLLOWING:</b> <ul style="list-style-type: none"><li>■ ADDED MOVABLE STORAGE UNITS (MSU)</li><li>■ REVISED APPROVED COATINGS LIST</li><li>■ REVISED APPENDIX A: COATING SYSTEMS</li><li>■ REVISED SURFACE PREPARATION AND COATING APPLICATION INSPECTION REQUIREMENTS &amp; RESPONSIBILITIES</li><li>■ ADDED PROCEDURE FOR PAINTING CYLINDER THREADS</li><li>■ ADDED PROCEDURE FOR APPLYING POLYURETHANE FINISH COAT OVER VINYL FINISH COAT</li><li>■ ADDED DISCREPANCY CHANGE NOTICE (DCN) FIGURE 23</li><li>■ ADDED CAULKING DETAILS, FIGURE 24</li><li>■ ADDED APPENDIX COVERING CHASSIS REPLACEMENT, APPENDIX E</li><li>■ ADDED PROCEDURE FOR PERFORMING SPOT REPAIRS WITH COMPLETE FINISHCOAT</li><li>■ ADDED FIGURES 25-29 TO IMPROVE THE DOCUMENTATION AND CONTROL OF COATING APPLICATIONS TO TRAILERS/MSUs</li><li>■ ADDED SHEETS 164 - 174</li></ul>	JUNE, 1993

TABLE OF CONTENTS

<u>PARAGRAPH</u>		<u>PAGE</u>
1.0	SCOPE .....	16
1.1	SERVICES .....	16
1.2	TRAILER/MSU TYPES .....	17
<b>2.0</b>	<b>APPLICABLE DOCUMENTS .....</b>	<b>17</b>
3.0	GENERAL REQUIREMENTS .....	21
3.1	TRANSPORTATION .....	21
3.1.1	RECEIPT AND DELIVERY .....	21
3.1.2	TYPE MOVER .....	22
3.1.3	LICENSE TAG .....	22
3.1.4	TRAILER TRANSIT SPEED .....	22
3.1.5	COMPLIANCE TO REGULATIONS .....	22
3.1.6	LOAD TIE DOWN .....	23
3.2	SUBCONTRACTOR FACILITY .....	23
3.2.1	SUBCONTRACTOR RECORDS .....	24
3.3	SCHEDULE REQUIREMENTS .....	24
3.4	PRECLEANING SAMPLES .....	24
3.5	REJECTED ITEMS .....	24
3.6	SAFETY CONSIDERATIONS .....	25
3.6.1	GENERAL .....	25
3.6.2	WASTE DISPOSAL .....	25
3.6.3	SAFED CONDITION .....	25
3.6.4	PERSONAL PROTECTIVE EQUIPMENT (PPE) .....	25
3.7	TRAILER/MSU IDENTIFICATION .....	25
3.8	DOCUMENTATION .....	26
3.8.1	DATA PACKAGE .....	26
3.8.2	RESPONSIBILITY .....	27
3.9	CONTRACTOR FURNISHED ITEMS .....	27
3.9.1	DATA AND FORMS .....	27
3.10	DISCARDED ITEMS .....	28
3.11	INSPECTIONS/VERIFICATIONS .....	28
3.11.1	COMPONENT AVAILABILITY VERIFICATION .....	28
3.11.2	ANNUAL WALKDOWN INSPECTION .....	28
3.11.3	DISASSEMBLY WALKDOWN INSPECTION .....	29
3.12	MISCELLANEOUS WORK .....	29
3.13	ENGINEERING SERVICES .....	29
<b>4.0</b>	<b>DISASSEMBLY OF TRAILER/MSU .....</b>	<b>30</b>

TABLE OF CONTENTS

<u>PARAGRAPH</u>		<u>PAGE</u>
4.1	MANIFOLD ASSEMBLY .....	30
4.2	CYLINDERS .....	31
4.3	CHASSIS .....	32
<b>5.0</b>	<b>REASSEMBLY OF TRAILER/MSU .....</b>	<b>32</b>
5.1	GENERAL .....	32
5.2	DAMAGED SURFACES .....	32
5.3	CYLINDER MOUNTING SPACER REPLACEMENT .....	32
5.4	SEALING .....	33
5.5	REASSEMBLED TRAILER/MSU CONFIGURATION .....	34
5.6	DOCUMENTATION .....	34
<b>6.0</b>	<b>REHABILITATION, INSPECTION &amp; LUBRICATION OF</b>	
	<b>TRAILER/CHASSIS .....</b>	<b>34</b>
6.1	RESPONSIBILITY .....	34
6.2	REHABILITATION OF TRAILER .....	34
6.2.1	GROUNDING REEL .....	34
6.2.2	FASTENERS AND NONMETALLIC GOODS .....	35
6.2.3	LIGHTS .....	35
6.2.4	WIRING, CONDUIT AND CONNECTIONS .....	36
6.2.5	WHEEL BEARINGS .....	36
6.2.6	BRAKES .....	36
6.2.7	AIR BRAKE SYSTEM .....	36
6.2.8	REFLECTORS .....	36
6.3	CHASSIS INSPECTION .....	36
6.3.1	SPRINGS .....	37
6.3.2	AXLES .....	37
6.3.3	WHEELS .....	37
6.3.4	TIRES .....	37
6.3.5	LANDING GEAR .....	37
6.3.6	RUNNING GEAR .....	37
6.3.7	FRAME .....	38
6.3.8	MANIFOLD ASSEMBLY COMPARTMENT DOORS, HINGES AND LATCHES .....	38
6.3.9	FIFTH WHEEL AND KINGPIN .....	38
6.3.10	FENDERS .....	38
6.3.11	BULKHEAD AND CYLINDER MOUNTING HARDWARE .....	38
6.3.12	MANIFOLD ASSEMBLY COMPARTMENTS .....	38
6.4	LUBRICATION .....	39

TABLE OF CONTENTS

<u>PARAGRAPH</u>		<u>PAGE</u>
<b>7.0</b>	<b>CYLINDER/CHASSIS/BULKHEAD REFURBISHMENT</b> .....	39
7.1	RESPONSIBILITY .....	39
7.2	TRAILER/MSU REPAIR .....	39
7.3	WELDING .....	40
7.3.1	QUALIFICATION OF WELDING PROCEDURES AND WELDERS .....	40
7.3.2	JOINT PREPARATION .....	40
7.3.3	MATERIALS .....	40
7.3.4	TACK WELDING .....	40
7.3.5	WELD BEADS .....	41
7.3.6	POSTWELD CLEANING .....	41
7.3.7	INSPECTION REQUIREMENTS .....	41
7.4	MANIFOLD ASSEMBLY REPAIR OR REPLACEMENT .....	41
<b>8.0</b>	<b>CYLINDER VISUAL INSPECTION</b> .....	42
8.1	INSPECTION REQUIREMENT .....	42
8.1.1	INSPECTION EQUIPMENT .....	42
8.1.2	GENERAL CORROSION .....	42
8.1.3	LINE CORROSION .....	43
8.1.4	ISOLATED PITS .....	43
8.1.5	DENTS .....	43
8.1.6	CUTS, DIGS OR GOUGES .....	43
8.1.7	BULGES .....	43
8.1.8	NECK DEFECTS .....	43
8.1.9	THREAD DEFECTS .....	44
8.1.10	OTHER DEFECTS .....	44
8.2	INTERNAL INSPECTION .....	44
8.2.1	INITIAL INSPECTION .....	44
8.2.2	CYLINDER INTEGRITY INSPECTION .....	44
8.2.3	CORROSION .....	44
<b>9.0</b>	<b>HYDROSTATIC TESTING</b> .....	44
<b>10.0</b>	<b>CYLINDER CLEANING</b> .....	45
10.1	RESPONSIBILITY .....	45
10.2	BASIC REQUIREMENTS .....	45
10.2.1	GENERAL .....	45
10.2.2	PRECLEANING SAMPLING ANALYSIS .....	45
10.2.3	EQUIPMENT CONFIGURATION .....	45
10.2.4	POSITION OF CYLINDER .....	45

TABLE OF CONTENTS

<u>PARAGRAPH</u>		<u>PAGE</u>
10.2.5	TECHNIQUES .....	46
10.2.6	INSPECTION REQUIREMENTS .....	46
10.2.7	CLEANLINESS REQUIREMENTS .....	46
10.2.8	PARTICULATE ANALYSIS .....	46
10.2.9	NONVOLATILE RESIDUE .....	46
10.2.10	INTEGRITY REQUIREMENT .....	46
10.3	CLEANING MATERIALS .....	47
10.3.1	BIODEGRADABLE DETERGENT .....	47
10.3.2	DEMINERALIZED WATER .....	47
10.3.3	ISOPROPYL ALCOHOL .....	47
10.3.4	NITROGEN .....	47
10.3.5	OAKITE 33 .....	47
10.3.6	pH PAPER .....	47
10.3.7	PHOSPHORIC ACID .....	48
10.3.8	SODIUM HYDROXIDE .....	48
10.3.9	SOLVENT .....	48
10.4	CLEANING EQUIPMENT .....	48
10.5	CLEANING METHOD NO. 1 .....	49
10.5.1	SOLVENT FLUSHING .....	49
10.5.2	INITIAL DRYING .....	49
10.5.3	INTERNAL INSPECTION .....	50
10.5.4	SAMPLING FOR CLEANLINESS LEVEL DETERMINATION .....	50
10.5.4.1	SOLVENT FLUSH .....	50
10.5.4.2	SAMPLING REQUIREMENT .....	50
10.5.4.3	ANALYSIS REQUIREMENT .....	50
10.6	CLEANING METHOD NO. 2 .....	50
10.6.1	DEGREASING .....	50
10.6.2	WATER RINSE .....	51
10.6.3	WATER SCOURING .....	51
10.6.4	DERUSTING AND PASSIVATION .....	51
10.6.5	ALCOHOL RINSE .....	51
10.6.6	INITIAL DRYING .....	51
10.6.7	INTERNAL INSPECTION .....	51
10.6.8	SAMPLING FOR CLEANLINESS LEVEL DETERMINATION .....	52
10.7	DRYING AND SEALING CYLINDER .....	52
10.7.1	CYLINDER DRYING .....	52
10.7.2	CYLINDER PLUG BACKUP RING AND O-RING REPLACEMENT .....	52
10.7.3	CYLINDER TORQUE VALUES .....	52
10.7.4	SEALING AND PRESERVATION .....	53

TABLE OF CONTENTS

<u>PARAGRAPH</u>		<u>PAGE</u>
10.7.5	INTEGRITY CONTROL REQUIREMENT .....	53
<b>11.0</b>	<b>TESTING OF MANIFOLD ASSEMBLIES .....</b>	<b>53</b>
11.1	HYDROSTATIC TEST OF MANIFOLD ASSEMBLIES .....	53
11.1.1	PRESSURE REQUIREMENT .....	53
11.1.2	TEST PROCEDURE .....	54
11.1.3	ACCEPTANCE REQUIREMENT .....	54
11.2	FUNCTIONAL TEST OF MANIFOLD ASSEMBLY .....	54
11.2.1	FUNCTIONAL TEST OF HAND VALVES .....	54
11.2.1.1	TEST PROCEDURE .....	55
11.2.2	FUNCTIONAL TEST OF REGULATORS .....	55
11.2.2.1	TEST PROCEDURE .....	55
11.2.3	FUNCTIONAL TEST OF DOME LOADED REGULATORS .....	57
11.2.3.1	TEST PROCEDURE .....	57
11.2.4	FUNCTIONAL TEST OF RELIEF VALVES .....	58
11.2.4.1	TEST PROCEDURE .....	58
11.2.5	FUNCTIONAL TEST OF PRESSURE GAGES .....	59
11.2.5.1	REQUIREMENT .....	59
11.2.5.2	TEST PROCEDURE .....	59
11.2.6	FUNCTIONAL TEST OF OUTLET CHECK VALVES .....	60
11.2.6.1	TEST PROCEDURE .....	60
11.2.7	FUNCTIONAL TEST OF INLET CHECK VALVES .....	60
11.3	LEAK TEST OF MANIFOLD ASSEMBLY .....	61
11.3.1	REQUIREMENT .....	61
11.3.2	PROCEDURE .....	61
11.4	DOCUMENTATION .....	62
<b>12.0</b>	<b>REHABILITATION OF MANIFOLD ASSEMBLY .....</b>	<b>62</b>
12.1	BASIC REQUIREMENT .....	62
12.2	DISASSEMBLY OF COMPONENTS .....	62
12.3	REPLACEMENT ITEMS .....	62
12.4	INSPECTION .....	63
12.5	REPAIR .....	63
12.6	CLEANING .....	63
12.7	REASSEMBLY OF COMPONENTS .....	64
12.7.1	MARKING OF COMPONENTS .....	64
12.8	TESTING OF COMPONENTS .....	64
12.9	SEALING .....	64
12.10	REASSEMBLY OF MANIFOLD ASSEMBLY .....	65
12.10.1	INTEGRITY OF CLEANLINESS LEVEL .....	65

TABLE OF CONTENTS

<u>PARAGRAPH</u>		<u>PAGE</u>
12.10.2	MANIFOLD ASSEMBLY TORQUE VALUES .....	65
12.10.3	LUBRICATION OF MANIFOLD ASSEMBLY THREADS .....	65
<b>13.0</b>	<b>CLEANING OF MANIFOLD ASSEMBLIES .....</b>	<b>66</b>
13.1	REQUIREMENTS .....	66
13.2	CLEANING MATERIALS .....	66
13.2.1	BIODEGRADABLE DETERGENT .....	66
13.2.2	ISOPROPYL ALCOHOL .....	66
13.2.3	NITRIC ACID .....	66
13.2.4	NITROGEN .....	66
13.2.5	OAKITE 33 .....	66
13.2.6	pH PAPER .....	66
13.2.7	PHOSPHORIC ACID .....	67
13.2.8	SOLVENT .....	67
13.3	CLEANING PROCEDURE FOR MANIFOLD ASSEMBLIES .....	67
13.3.1	DEGREASE .....	67
13.3.2	DETERGENT CLEANING .....	67
13.3.3	INITIAL RINSE .....	68
13.3.4	ACID IMMERSION .....	68
13.3.5	FINAL RINSE .....	69
13.3.5.1	ALCOHOL RINSE .....	69
13.3.5.2	WATER RINSE .....	69
13.4	INITIAL DRYING .....	69
13.5	INITIAL INSPECTION .....	69
13.6	SOLVENT FLUSH AND TESTING .....	69
13.7	FINAL DRYING .....	70
13.8	SEALING .....	70
13.9	CLEANING PROCEDURE FOR PRESSURE GAGES .....	70
13.9.1	GAGE EXTERIOR .....	70
13.9.2	GAGE INTERIOR .....	70
13.9.2.1	GAGES WITH BLEED PORTS .....	71
13.9.2.2	GAGES WITHOUT BLEED PORTS .....	71
13.9.3	DRYING .....	71
<b>14.0</b>	<b>SAMPLE ANALYSIS PROCEDURES .....</b>	<b>71</b>
14.1	PARTICULATE ANALYSIS PROCEDURE .....	71
14.2	NONVOLATILE RESIDUE ANALYSIS PROCEDURE .....	72
<b>15.0</b>	<b>QUALITY ASSURANCE PROVISIONS .....</b>	<b>74</b>
15.1	GENERAL .....	74



TABLE OF CONTENTS

<u>PARAGRAPH</u>		<u>PAGE</u>
15.2	CONFIGURATION CONTROL .....	74
15.3	HYDROSTATIC TEST FACILITY .....	74
15.4	CHEMICALS AND MATERIALS .....	74
15.5	COMPONENT CONTROL .....	74
15.6	FACILITY CONTROL .....	75
15.7	SUBMITTALS .....	75
15.7.1	DOT HYDROSTAT/INSPECTION CERTIFICATION .....	75
15.7.2	CHEMICAL SAMPLING PLAN .....	75
15.7.3	CLEANING PROCEDURE .....	75
15.7.4	WELDER QUALIFICATIONS .....	76
15.7.5	TUBE FABRICATION PROCEDURE .....	76
15.7.6	LUBRICANT CERTIFICATION .....	76
15.7.7	LIST OF "SUBSTITUTIONS" .....	76
<b>16.0</b>	<b>PREPARATION FOR DELIVERY .....</b>	<b>76</b>
16.1	PREPARATIONS .....	76
16.1.1	LICENSE TAG .....	76
16.1.2	LUBRICATION .....	76
16.1.3	LEAK CHECK .....	77
16.1.4	TRAILER/MSU PRESSURIZATION .....	77
16.2	FINAL INSPECTION .....	77
<b>17.0</b>	<b>EXCEPTIONS AND DEVIATIONS .....</b>	<b>77</b>
<b>18.0</b>	<b>APPENDIX A: COATING SYSTEMS .....</b>	<b>78</b>
A1.0	PREPARATION AND APPLICATION OF COATING SYSTEMS .....	78
A1.1	DOCUMENTATION .....	78
A2.0	EQUIPMENT .....	78
A2.1	GENERAL .....	78
A2.2	COMPRESSED AIR .....	78
A2.3	ABRASIVE BLASTING SYSTEM .....	78
A2.4	COATING APPLICATION SYSTEM .....	79
A2.5	NEEDLE SCALER .....	79
A3.0	MATERIAL REQUIREMENTS .....	79
A3.1	COATINGS .....	79
A3.1.1	SOURCE OF SUPPLY .....	79
A3.2	COLOR REQUIREMENTS .....	79
A3.2.1	WHEELS .....	80
A3.2.2	QUICK DISCONNECTS .....	80

TABLE OF CONTENTS

<u>PARAGRAPH</u>		<u>PAGE</u>
A3.2.3	ALIGNMENT MARK .....	80
A3.3	ABRASIVE BLASTING AGGREGATE .....	80
A3.4	INORGANIC ZINC PRIMER .....	80
A4.0	PROCEDURES .....	80
A4.1	APPLICATOR QUALIFICATIONS .....	80
A4.2	PREPARATION OF SURFACES .....	81
A4.2.1	PROTECTION OF EQUIPMENT AND ADJACENT SURFACES .....	81
A4.2.2	DEGREASING .....	81
A4.2.3	MECHANICAL CLEANING .....	82
A4.2.4	EDGE FEATHERING .....	82
A4.2.5	WATERBLASTING .....	82
A4.2.6	DUST REMOVAL .....	83
A4.3	STORAGE OF COATING MATERIALS .....	83
A4.4	MIXING INSTRUCTIONS .....	83
A4.5	ENVIRONMENTAL CONDITIONS .....	83
A4.6	APPLICATION OF COATINGS .....	83
A4.6.1	STRIPE COATING .....	84
A4.7	COATING FINISH .....	84
A4.8	COATING DRY FILM THICKNESS (DFT) .....	85
A4.9	COATING DRYING AND CURING .....	85
A5.0	COMPLETE REFURBISHMENT OF CARBON STEEL SURFACES .....	85
A5.1	SURFACE PREPARATION .....	86
A5.1.1	ABRASIVE BLAST CLEANING .....	86
A5.1.2	EXCESSIVE RUST AND SCALE .....	86
A5.2	BLAST CLEANED SURFACE FINISH .....	86
A5.3	PRIMER .....	86
A5.3.1	WATER WASH AND SCRUB .....	87
A5.4	INTERMEDIATE COAT .....	87
A5.5	SEALING .....	87
A5.6	FINISH COAT .....	87
A6.0	COMPLETE REFURBISHMENT OF ALUMINUM SURFACES .....	87
A6.1	SURFACE PREPARATION .....	87
A6.1.1	ABRASIVE BLAST CLEANING .....	88
A6.1.2	STRIPPING .....	89
A6.1.3	SANDING .....	89
A6.1.4	CORROSION REMOVAL COMPOUND .....	89
A6.3	PRIMER .....	90

TABLE OF CONTENTS

<u>PARAGRAPH</u>		<u>PAGE</u>
A6.4	SEALING .....	
A6.5	FINISH COAT .....	90
A7.0	TOUCHUP REFURBISHMENT OF SURFACES .....	90
A7.1	SURFACE PREPARATION .....	90
A7.2	PRIMER/INTERMEDIATE COAT APPLICATION .....	90
A7.3	SEALING .....	90
A7.4	FINISH COAT .....	91
A8.0	TOUCHUP OF FINISH COAT .....	91
A8.1	SURFACE PREPARATION .....	91
A8.2	FINISH COAT TOUCHUP .....	91
A9.0	REFURBISHMENT OF VINYL FINISH COAT WITH APPLICATION OF POLYURETHANE FINISH COAT .....	91
A9.1	SURFACE PREPARATION .....	91
A9.2	PRIMER .....	91
A9.3	SANDING .....	92
A9.5	INTERMEDIATE COAT .....	92
A9.6	FINISH COAT .....	92
A10.0	SPOT REPAIR WITH COMPLETE FINISH COAT .....	92
A10.1	SURFACE PREPARATION .....	92
A10.2	PRIMER .....	92
A10.3	SEALING .....	93
A10.4	FINISH COAT .....	93
A11.0	PROCEDURE FOR PAINTING CYLINDER THREADS .....	93
A11.1	SURFACE PREPARATION .....	93
A11.2	EPOXY PRIMER .....	93
A11.3	INSTALL BACKUP NUTS .....	93
A11.4	PROTECTION OF ADJACENT CYLINDER THREADS .....	94
A11.5	FINISH COAT .....	94
A11.6	INSTALLATION OF CYLINDERS AND BULKHEAD NUTS .....	94
A11.7	COATING CYLINDER ENDS .....	94
A12.0	QUALITY ASSURANCE PROVISIONS .....	94
A12.1	RESPONSIBILITY FOR INSPECTION .....	94
A12.2	INSPECTION HOLD POINTS .....	94
A12.3	INSPECTION PRIOR TO SURFACE PREPARATION AND COATING APPLICATION .....	95
A12.3.1	SURFACE CONDITION .....	95
A12.3.2	PROTECTION OF ADJACENT SURFACES .....	95
A12.3.3	AMBIENT WEATHER CONDITIONS .....	96
A12.3.4	COMPRESSED AIR CLEANLINESS .....	96
A12.4	SURFACE PREPARATION INSPECTION .....	96

TABLE OF CONTENTS

<u>PARAGRAPH</u>		<u>PAGE</u>
A12.4.1	ABRASIVE BLASTING MATERIAL .....	96
A12.4.2	BLAST NOZZLE AIR PRESSURE AND SIZE .....	96
A12.4.3	DEGREE OF SURFACE CLEANLINESS .....	97
A12.4.4	SURFACE PROFILE OR ROUGHNESS .....	97
A12.5	COATING APPLICATION INSPECTION .....	97
A12.5.1	SURFACE CONDITION .....	97
A12.5.2	COATING MATERIALS .....	97
A12.5.3	STORAGE OF COATING MATERIAL .....	98
A12.5.4	MIXING AND APPLICATION OF COATINGS .....	98
A12.5.5	COATING FINISH AND DFT .....	98
<b>19.0</b>	<b>APPENDIX B: HYDROSTATIC TESTING .....</b>	<b>99</b>
B1.0	CYLINDER HYDROSTATIC TEST .....	99
B1.1	HYDROSTATIC TEST BASIC REQUIREMENTS .....	99
B1.2	METHOD OF TEST .....	99
B1.3	TEST PRESSURE .....	99
B1.4	TEST APPARATUS .....	99
B1.5	INSTRUCTIONS FOR CARE OF CALIBRATED CYLINDER .....	101
B1.6	INSTRUCTIONS FOR USE OF CALIBRATED CYLINDER .....	101
B1.7	TEST WATER .....	102
B2.0	HYDROSTATIC TEST PROCEDURE .....	102
B3.0	CYLINDER STAMPING .....	104
B3.1	RETEST DATE .....	104
B3.2	MARKING SIZE .....	104
B3.3	PREVIOUS MARKINGS .....	104
B3.4	LOCATION .....	104
B3.5	LEGIBILITY .....	104
<b>20.0</b>	<b>APPENDIX C: DEFINITIONS .....</b>	<b>105</b>
C1.0	DEFINITIONS .....	105
C1.1	TRAILER .....	105
C1.2	TRAILER CHASSIS .....	105
C1.3	CYLINDER .....	105
C1.4	MANIFOLD ASSEMBLY .....	105
C1.5	COMPONENT .....	105
C1.6	DEWPOINT .....	105
C1.7	MOVABLE STORAGE UNIT (MSU) .....	105
C1.8	GN <sub>2</sub> .....	106
C1.9	CFE .....	106
C1.10	BOC .....	106

TABLE OF CONTENTS

<u>PARAGRAPH</u>		<u>PAGE</u>
C1.11	CONFIGURATION CONTROL .....	106
<b>21.0</b>	<b>APPENDIX D: MANIFOLD ASSEMBLY REPLACEMENT .....</b>	<b>107</b>
D1.0	SCOPE .....	107
D2.0	GENERAL REQUIREMENTS .....	107
D2.1	GENERAL PROJECT DESCRIPTION .....	107
D2.2	GENERAL FABRICATION REQUIREMENTS .....	107
D2.2.1	WELDING .....	107
D2.2.2	BRAZING .....	107
D2.2.3	FASTENERS .....	108
D2.3	TUBING SYSTEMS REQUIREMENTS .....	108
D2.3.1	TUBE ASSEMBLIES .....	108
D2.3.2	TUBE ASSEMBLY DIMENSIONAL CHECKS .....	108
D2.3.3	ASSEMBLY .....	108
D2.3.4	TUBE SUPPORTS .....	109
D2.3.5	COMPONENT SUPPORTS .....	109
D2.4	CORROSION CONTROL AND PROTECTIVE COATING .....	109
D2.4.1	ALUMINUM & CARBON STEEL .....	109
D2.5	TUBING HYDROSTATIC TESTING REQUIREMENTS .....	109
D2.5.1	TESTING .....	109
D2.5.2	DOCUMENTATION .....	109
D2.5.3	TUBING IDENTIFICATION .....	110
D2.6	CLEANING OF TUBING/COMPONENT SYSTEMS .....	110
D2.7	MANIFOLD ASSEMBLY INSTALLATION .....	111
D3.0	PNEUMATIC AND FUNCTIONAL TESTING .....	111
D3.1	COMPONENT LEAK TEST .....	111
D3.2	FUNCTIONAL TEST .....	111
D3.3	PNEUMATIC TEST .....	111
D4.0	SUBMITTALS .....	111
D4.1	FINAL DATA PACKAGE .....	111
D4.1.1	AS-BUILTS .....	112
D4.1.2	HYDROSTAT DOCUMENTATION .....	112
D4.2	CERTIFICATIONS .....	112
D4.2.1	TEST DATA .....	112
D4.2.2	TUBE FLARING AND BRAZING REQUIREMENTS .....	112
<b>22.0</b>	<b>APPENDIX E: CHASSIS REPLACEMENT .....</b>	<b>113</b>
E1.0	SCOPE .....	113
E2.0	GENERAL REQUIREMENTS .....	113
E2.1	PRE-DELIVERY INSPECTION .....	113

TABLE OF CONTENTS

<u>PARAGRAPH</u>		<u>PAGE</u>
E2.2	GENERAL FABRICATION REQUIREMENTS .....	113
E2.2.1	PREFIT AND DIMENSIONAL CHECKS .....	113
E2.2.2	WELDING .....	114
E2.2.3	CYLINDER PLACEMENT .....	114
E2.2.4	CYLINDER MOUNTING SPACER PLACEMENT .....	114
E2.3	DOCUMENTATION .....	114
E2.3.1	AS-BUILTS .....	114
23.0	APPENDIX F: TRAILER DATA .....	115
24.0	APPENDIX G: TABLES/FIGURES .....	125
24.0	APPENDIX H: WORK FLOW DIAGRAM .....	169
25.0	APPENDIX J: MISCELLANEOUS DOCUMENTS .....	171

**LIST OF TABLES**

<u>TABLE</u>		<u>PAGE</u>
1	TRAILER TYPES .....	126
2	ALLOWABLE WELDING DEFECTS LIMIT .....	131
3	APPROVED COATINGS PRODUCT LIST .....	132

**LIST OF FIGURES**

<u>FIGURE</u>		<u>PAGE</u>
1	CYLINDER CONFIGURATION .....	133
2	CLEANING SYSTEM SCHEMATIC .....	134
3	HYDROSTATIC TEST APPARATUS SCHEMATIC .....	135
4	SCHEMATIC FOR FUNCTIONAL TEST - HANDVALVE .....	136
5	SCHEMATIC FOR FUNCTIONAL TEST - REGULATOR .....	137
6	SCHEMATIC FOR FUNCTIONAL TEST - DOME LOADED REG ...	138
7	SCHEMATIC FOR FUNCTIONAL TEST - RELIEF VALVE .....	139
8	SCHEMATIC FOR FUNCTIONAL TEST - PRESSURE GAGE .....	140
9	CHECKLIST OF COMPLETED ITEMS .....	141
10	RECEIVING INSPECTION OF TRAILER .....	144
11	CYLINDER LOCATION CHART .....	145
12	PRE-CLEANING SAMPLE ANALYSIS .....	146
13A	INSPECTION OF TRAILER CHASSIS .....	147
13B	INSPECTION OF MSU .....	148
14	CYLINDER INSPECTION REPORT FORM .....	149
15	CYLINDER HYDROSTATIC TEST RESULTS .....	150
16	LABORATORY ANALYSIS OF CLEANING SAMPLES .....	151
17	TEST RESULTS - MANIFOLD ASSEMBLY .....	152
18	REQUEST FOR INFORMATION (RFI) .....	155
19	FINAL INSPECTION OF TRAILER .....	156
20	COMPONENT/GOOD AVAILABILITY .....	157
21	DATA PACKAGE COVER SHEET .....	158
22	TYPICAL STATEMENT OF WORK (SOW) .....	160
23	DISCREPANCY CHANGE NOTICE (DCN) .....	162
24	CAULKING: CYLINDER - BULKHEAD INTERFACE .....	163
25	DRY FILM THICKNESS MEASUREMENT WORKSHEET .....	164
26	COATING SYSTEM DAILY INSPECTION REPORT .....	165
27	COATING SYSTEM DAILY INSPECTION REPORT (CONTINUATION SHEET) .....	166
28	COATING SYSTEM NON-CONFORMANCE REPORT .....	167
29	COATING SYSTEM CONFORMANCE VERIFICATION REPORT ...	168

## 1.0 SCOPE

This standard contains the minimum requirements for the testing, cleaning, repairing, repainting, and general re-manufacturing of compressed gas trailers (hereinafter called trailer) and movable storage units (hereinafter called MSU) to a "like-new" condition. For purposes of this standard the Base Operations Contractor (BOC) is defined as the Contractor. The organization performing the work, in accordance with this standard, shall be defined as the Subcontractor.

Any revisions and/or changes to this Document must be evaluated for impacts to the Department of Transportation's (DOT) 10 year hydrostatic test exemption: DOT-E 9740.

## 1.1 SERVICES

This standard encompasses the following services:

- a. Transportation of the trailer/MSU from Kennedy Space Center (KSC) to the Subcontractor's site and from the Subcontractor's site to KSC.
- b. Removal of cylinders, manifold assemblies and other items designated herein from the trailer and MSU bulkheads and supports.
- c. Inspection, cleaning, testing, painting, and integrity control of the cylinders.
- d. Inspection, repair, modification, replacing, cleaning, and painting of the trailer chassis and storage unit bulkheads, panels, cabinets, and support structure.
- e. Inspection, rehabilitation, replacing, cleaning, testing, and integrity control of the manifold assemblies.
- f. Reassembly of the manifold assemblies and cylinders onto the trailer chassis and storage unit support structure.
- g. Documentation requirements covering the retest and refurbishment in detail.



**1.2 TRAILER/MSU TYPES**

This standard covers Types I through VI, VIII, and IX trailers and Series 100 through 300 MSUs. See Table 1 and Figure 1 for pertinent physical data for each type.

**2.0 APPLICABLE DOCUMENTS**

The following documents, or subsequent revisions, in effect on date of issue of invitation for bids or requests for proposals form a part of this standard and, where referred to thereafter by basic designation only, are applicable to the extent indicated by the reference thereto.

In the event of conflict between the documents referenced herein and the contents of this standard, the contents of this standard shall govern. Conflicts noted by the Subcontractor must be brought to the attention of the BOC Subcontract Administrator for resolution, prior to further processing of trailers/MSUs.

**SPECIFICATIONS**

**Federal**

BB-N-411C	Nitrogen, Technical
O-C-265B	Chemicals, Analytical; General Specification for
O-N-350B	Nitric Acid, Technical
O-O-670B	Orthophosphoric (Phosphoric) Acid, Technical
O-S-598B	Sodium Hydroxide
PPP-T-66	Tape, Pressure Sensitive
TT-I-735A	Isopropyl Alcohol, Specification for
TT-M-261	Methylethylketone, Technical
TT-S-230A	Sealing Compound, Synthetic Rubber Base, Single Component, Chemically Curing (for Caulking and glazing in building construction

TT-T-266 Thinner: Dope and Lacquer (Cellulose Nitrate)

Johnson Space Center

MSC-SN-C-0037 Trichlorotrifluoroethane Solvent, Use Requirements

MSC-SPEC-C-2A Garments, Clean Room, Specification For

John F. Kennedy Space Center

KSC-SPEC-Z-0004 Welding of Structural Carbon Steel, Low Alloy Steel, and Aluminum Alloys, Specification for

KSC-SPEC-Z-0005 Brazing, Steel, Copper, Aluminum, Nickel, and Magnesium Alloys, Specification for

KSC-SPEC-Z-0007 Tubing, Steel, Corrosion Resistant, Types 304 and 316, Seamless, Annealed, Specification for

KSC-SPEC-Z-0008 Fabrication and Installation of Flared Tube Assemblies and Installation of Fittings and Fitting Assemblies, Specification for

KSC-SPEC-Z-0009 Lubrication, Thread Corrosion Resistant Steel Tube Fittings, Specification for

KSC-C-123F Surface Cleanliness of Fluid Systems, Specification for

Military

MIL-B-22191D Barrier Materials, Transparent, Flexible, Heat Sealable

MIL-C-16173D Corrosion Preventative Compound, Solvent cutback, Cold Application

MIL-C-38334A Corrosion Removing Compound

MIL-C-81302D Cleaning Compound, Solvent, Trichlorotrifluoroethane

MIL-D-6998D	Dichloromethane, Technical
MIL-G-9954A	Abrasive Grain (Glass Beads)
MIL-G-10924E	Grease, Automotive and Artillery
MIL-L-2104E	Lubricating Oil, Internal Combustion Engine, Tactical Service
MIL-L-25567D	Leak Detection Compound, Oxygen Systems (Metric)
MIL-T-27730A	Tape, Antiseize, Polytetrafluoroethylene, with Dispenser

STANDARDS

ASTM

ASTM-F-51-68T	Sizing and Counting Particulate Contaminant in and on Clean Room Garments
---------------	--

AMERICAN WELDING SOCIETY

D1.1	Structural Welding Code Steel
D1.2	Structural Weiding Code Aluminum

COMPRESSED GAS ASSOCIATION

C-1	Methods for Hydrostatic Testing of Compressed Gas Cylinders
C-6	Standards for Visual Inspection of Compressed Gas Cylinders

Federal

FED-STD-209	Clean Room and Work Station Requirements, Controlled Environment
FED-STD-595	Colors

NATIONAL ASSOCIATION OF CORROSION ENGINEERS (NACE)

TM-01-70                      Visual Standard for Surfaces of New Steel  
Airblast Cleaned with Abrasive Sand

STEEL STRUCTURES PAINTING COUNCIL (SSPC)

SSPC-PA 2                      Measurement of Dry Paint Thickness With  
Magnetic Gages

SSPC-SP 1                      Solvent Cleaning

SSPC-SP 2                      Hand Tool Cleaning

SSPC-SP 3                      Power Tool Cleaning

SSPC-SP 10                      Near-White Blast Cleaning

SSPC-SP 11                      Power Tool Cleaning to Bare Metal

SSPC-AB 1                      Mineral and Slag Abrasives

SSPC-VIS 1                      Pictorial Surface Preparation Standard for  
Painting Steel Surfaces

MOTOR VEHICLE CODE

DOT-E 9740                      DOT exemption for 10 year hydrostatic test  
interval.

49CFR 393.11                      Lighting/Reflectors

49CFR 173.34                      Qualification, Maintenance and Use of  
Cylinders

OCCUPATIONAL SAFETY AND HEALTH ADMINISTRATION (OSHA)

29CFR 1910.134                      Respiratory Protection

FEDERAL ACQUISITION REGULATION

45.611

MATERIAL SELECTION LISTS

79K09561                      Material Selection List for Gaseous Oxygen  
and Air Service, MSL-GOX

NASA HANDBOOKS

NHB 8060.1                      Flammability, Odor, and Offgassing  
Requirements and Test Procedures for  
Materials in Environments that Support  
Combustion

Copies of specifications, standards, drawings, and publications required by Subcontractors in connection with specific procurement functions should be obtained from the procuring activity or as directed by the Subcontract Administrator.

**3.0                      GENERAL REQUIREMENTS**

It is intended that the performance of requirements specified herein will restore, to the maximum extent possible, the trailer(s)/ MSU(s) to a "like new condition." This "like new condition" shall include a coating system that, in conjunction with a thorough maintenance program , will provide corrosion protection for 10 years. Trailers shall be suitable for day or night operation on public highways.

**3.1                      TRANSPORTATION**

**3.1.1                    RECEIPT AND DELIVERY**

When receiving or shipping a trailer/MSU, the Subcontractor shall first;

- a.      Contact the Contractor to assure trailer/MSU is ready for pick up.
- b.      Stop at BOC shipping and receiving to assure completion of all required property transfer documents and forms. For trailers, the Subcontractor will be escorted to building K7-516 for trailer pickup. For MSU's, the BOC System Maintenance Engineer will meet the Subcontractor at shipping and receiving for travel to MSU location.

Trailer(s) shall be received at and returned to the Equipment Maintenance Area, North Building K7-516, KSC, Florida. MSU(s) shall be received at and returned to the user's site as directed by the BOC

System Maintenance Engineer. The Contractor's Quality Group shall complete (in duplicate) the NASA portion of the "Inspection at KSC" block of "Receiving Inspection of Trailer/MSU" form, Figure 10. One copy of this form shall be issued to the Subcontractor with the trailer/MSU. At the time of trailer/MSU pickup at KSC, a member of the Subcontractor's Organization shall complete the Subcontractor portion of the "Inspection at KSC" block to document and ensure trailer/MSU is suitable for transit and that critical systems such as brakes, lights, turn signals, etc. are operational. A copy of Figure 10 shall be incorporated into the completed trailer's/MSU's data package. At the time of receipt of the trailer/MSU, a designated representative of the Subcontractor shall sign a BOC prepared document DD Form 1149 indicating transfer of property control and responsibility from the Contractor to the Subcontractor. An example form 1149 is included in Appendix J. Hours for pickup and delivery shall be from 0800 to 1500 hours on standard scheduled work days at KSC. The Subcontractor is required to notify the BOC Subcontract Administrator a minimum of two working days prior to picking up or delivering an MSU.

**3.1.2 TYPE MOVER**

Tractor transportation provided by the Subcontractor shall be utilized for trailers. MSUs shall be transported by tractor trailer provided by the Subcontractor. Contractor shall provide lifting equipment at contractor site. Subcontractor shall provide lifting equipment at other sites. Shipment of trailers/MSUs by railcar is not permitted.

**3.1.3 LICENSE TAG**

A government license tag shall be provided by the Contractor for each trailer. The tractor and trailer provided by the Subcontractor to transport the MSU will be licensed to operate in all states through which it may travel.

**3.1.4 TRAILER TRANSIT SPEED**

Trailer/MSU transit speed shall not exceed 50 miles per hour.

**3.1.5 COMPLIANCE TO REGULATIONS**

During transit, the trailer/MSU shall be transported in accordance with federal (49CFR), state, and local regulations. Where trailers/MSUs are transported across state lines, the Subcontractor shall be responsible for

investigating federal and State highway regulations regarding over-the-road equipment weight and size limitations, licenses required, permits and such other regulations which may be applicable, and shall take whatever measures are necessary to adhere thereto.

### 3.1.6 LOAD TIE DOWN

The MSU will be securely tied down (per applicable DOT regulations) to the trailer bed in such a manner as to prevent damage to the MSU. Particular care shall be taken to protect the MSU corrosion protection system.

### 3.2 SUBCONTRACTOR FACILITY

The application of the paint coatings as defined within Appendix A of this standard shall be accomplished within the confines of a totally enclosed building of common construction. Totally enclosed is defined to mean that doors shall be closed during painting operations and the facility shall be sufficiently enclosed to prevent substantial access of sand, dust, or other foreign matter. The Subcontractor's painting facility shall have adequate ventilation to facilitate proper painting operations (e.g., ideal painting conditions include adequate air flow to remove the mist generated during the painting operations to prevent overspraying). Suitable water walls may be used as one method of improving painting conditions.

The Subcontractor's hydrostatic test facility shall be certified in accordance with the requirements of paragraph 15.3.

Final cleaning and packaging of manifold assemblies, components and related tubing shall be accomplished in the Subcontractor's clean room. This room shall be in accordance with FED-STD-209, class 5000, and shall be supported by a laboratory suitable for providing sample/non-volatile residue (NVR) analysis and controls over chemicals used under the direction of this standard. Clean room garments shall be per ASTM-F-51-68T.

The Subcontractor's facility shall provide adequate pumps, tanks and fixtures as required to support chemical and solvent handling, storage and circulation in order to comply with the requirements of this standard (KSC-SO-S-9). Handling and storage of chemicals and solvents shall be in compliance with all applicable federal and state regulations.

The Subcontractor shall have adequate facilities for the safe handling and erection of cylinders during their processing under this standard.

3.2.1 SUBCONTRACTOR RECORDS

Subcontractor records shall be available for the Contractor to verify proposed Request For Information (RFI), Figure 18, and Discrepancy Change Notice (DCN), Figure 23, costs/hours and actual costs/hours expended for various unit refurbishments throughout the term of the Subcontract.

3.3 SCHEDULE REQUIREMENTS

The contract shall specify and control receipt and delivery of the trailers/MSUs. The Subcontractor shall provide a critical path schedule (flow diagram of required tasks listed in the order of performance) for each trailer/MSU within 3 weeks of receipt of trailer/MSU. This schedule shall be computer generated using Prima Vera software or equal.

3.4 PRECLEANING SAMPLES

The Subcontractor shall perform precleaning sample analysis of cylinders on 3 cylinders from each trailer and on 1 cylinder from each MSU prior to the performance of any tests or refurbishment that may affect the cylinder's interior (refer to 10.2.2 for details). Results shall be documented on Figure 12.

3.5 REJECTED ITEMS

The Subcontractor shall document any rejected item on Figure 18. The reason for rejection shall be carefully and thoroughly detailed, including measurements and the applicable specification(s) controlling the rejection. The Subcontractor shall recommend corrective action; however, the disposition of rejected items shall be by the Subcontract Administrator or their representative. In the event cylinder(s) are rejected for continued service, the Subcontractor will replace cylinder(s) with direct replacement cylinder(s) and disposition rejected cylinder(s). Cylinders shall be Contractor Furnished Equipment (CFE) to the Subcontractor.



**3.6 SAFETY CONSIDERATIONS**

**3.6.1 GENERAL**

The Subcontractor shall perform the requirements specified herein in a safe manner and shall take whatever precautions deemed necessary for compliance with all established safety regulations, policies, practices, or techniques in performance of tests, in the handling of chemicals, flammables, or inert gases, in welding, blasting, and painting, and in the disassembly, lifting, and assembly of heavy components. Work performed under this standard shall be accomplished under the control of a published subcontractor safety manual, submitted to the Subcontract Administrator or their representative.

**3.6.2 WASTE DISPOSAL**

Subcontractor is responsible for disposal of all wastes in accordance with all federal, state and local regulations.

**3.6.3 SAFED CONDITION**

The trailer/MSU, at time of receipt by the Subcontractor, shall be in an inert condition and pressurized to 25 +0, -10 pounds per square inch gage (psig) with gaseous nitrogen (GN<sub>2</sub>), helium (GHe) or air. To ensure the Subcontractor receives trailer/MSU as stated, each cylinder on the trailer/MSU shall have had pressure and contents verified by the Contractor. A Quality Assurance stamp shall be placed on "Receiving Inspection of Trailer/MSU" form, Figure 10. "Pressurized to 25 +0, -10 psig" shall signify that each cylinder has been checked.

**3.6.4 PERSONAL PROTECTIVE EQUIPMENT (PPE)**

When engineering controls are not available to protect workers, then PPE and/or administrative controls shall be used. When required, PPE shall be provided, used, and maintained in a reliable and sanitary condition.

**3.7 TRAILER/MSU IDENTIFICATION**

Trailer (GT-) and MSU (MSU-) numbers and service media shall be clearly identified on the schedule (3.3) and on each page of all items submitted in the data package (3.8.1).

**3.8 DOCUMENTATION**

A data package shall be assembled by the Subcontractor for each trailer/MSU and shall accompany the trailer/MSU when delivered to KSC. The data package shall be hand delivered to the Contractor's designated representative.

Handwritten, printed, or typed information on data package forms shall be in black ink and shall be legible. Originals shall be provided whenever possible. Signatures and dates shall be legible and the name of the person signing any part of any data package form shall be printed in block letters adjacent to the signature. Corrections shall be made with a single line through the text and entry of the new data. Corrections shall be initialed and dated.

**3.8.1 DATA PACKAGE**

The data package shall consist of the following:

- a. Millipore filter pads containing the precleaning samples.
- b. The original and one copy of completed forms containing all data represented by Figure 9 through 29 inclusive.
- c. The original and two copies of completed DD Form 1149.
- d. Red line configuration drawing indicating any approved changes.
- e. Chemical certifications for all chemicals used under this standard.
- f. Material certifications for materials requiring gaseous oxygen (GO<sub>2</sub>) or breathing air (Bair) compatibility.
- g. Surface profile replica tape.
- h. Daily surface cleaning/preparation and painting inspection log.
- i. Welder certifications.
- j. Copy of any RFI's and Minor Discrepancy Change Notices (DCN) issued during refurbishment of the trailer/MSU.
- k. Tube bending/flaring certifications.

- l. Copy of manifold assembly hydrostat documentation per D2.5.2.
- m. Copy of contractor Quality Engineering "Q" points.
- k. Redlined/as built chassis drawings.
- l. Statement Of Work (SOW).

### 3.8.2 RESPONSIBILITY

The Subcontractor shall prepare (provide) the necessary forms as illustrated in Figure 9 through Figure 21 inclusive. Completion of form data (information) shall be verified (stamped) by a representative of the Subcontractor and a representative of the Contractor. A signature or stamp on any form is the Subcontractor's certification that the applicable steps of this standard have been performed. Completed forms shall be included as part of the data package.

### 3.9 CONTRACTOR FURNISHED ITEMS

The Contractor shall furnish items as specified herein and/or as specified in the SOW.

#### 3.9.1 DATA AND FORMS

Contractor furnished data and forms to be retained by the Subcontractor during the term of the contract include:

- a. Two copies of a set of configuration drawings for each trailer/MSU.
- b. One copy of compressed gas component specifications and prints.
- c. Copies of specifications and standards as required.
- d. Copies of DD Form 1149 as required (Example form included in Appendix H).
- e. Copies of KSC form 7-49 as required (Example form included in Appendix H).

**3.10 DISCARDED ITEMS**

All discarded trailer/MSU items (those items replaced by the Subcontractor as required by this standard) shall be dispositioned in accordance with Federal Acquisition Regulation 45.611. The discarded items shall be separated into heavy steel, light steel and aluminum. The Subcontractor shall complete a KSC form 7-49 which lists the type of material, weight and trailer(s)/MSU(s) the items came from. The items shall be transported to BOC property management by the Subcontractor at least every year.

Expendable items such as discarded softgoods, bolts, nuts, fasteners, etc., shall be disposed of by the Subcontractor (accountability to the Subcontract Administrator or their representative is not required).

**3.11 INSPECTIONS/VERIFICATIONS**

The Subcontractor shall perform the following inspections/verifications.

**3.11.1 COMPONENT AVAILABILITY VERIFICATION**

Three weeks after award of the subcontract the Subcontractor shall submit Figure 20 to verify that all components and softgoods are available from the respective vendors. If the softgoods are available the Subcontractor shall initiate action to procure them. If softgoods or valves are no longer manufactured the Subcontractor shall notify the Contractor of this immediately. This availability verification is required due to the age of the trailers/MSUs and components.

**3.11.2 ANNUAL WALKDOWN INSPECTION**

The Subcontractor is required to participate in an annual walkdown inspection, at KSC, prior to taking delivery of the trailer/MSU. The Subcontractor shall inspect all mechanical, pneumatic and structural components for damage, wear, distortion, or other forms of failure or potential failure. The Subcontractor shall be responsible for recommending to the Subcontract Administrator, or their representative, any needed repair, refurbishment or replacement of any item beyond the scope of the SOW for each trailer/MSU. All repair/replacement shall be approved by the Subcontract Administrator or their representative. The Contractor may revise the SOW for each trailer/MSU as a result of the walkdown inspection performed with the Subcontractor.

**3.11.3 DISASSEMBLY WALKDOWN INSPECTION**

Upon receipt of the trailer/MSU at the Subcontractor's facility, the subcontractor shall disassemble the trailer/MSU to the component level and perform a thorough walkdown inspection. This inspection shall include adequate surface cleaning (where required and where specified by the SOW) to determine the overall condition of the trailer/MSU. This inspection will include (as applicable), but shall not be limited to, inspection of the trailer frame, unit welds, axles, cabinets, panels, bulkheads, maxi-brakes, and inspection for hidden rust problems such as in the fifth wheel plate area and cylinder neck area. Any items not previously identified in the SOW shall be documented on an RFI or DCN, with the associated cost of performing the work, and submitted to the Subcontract Administrator for approval within three weeks from unit delivery. The disassembly inspection will be completed within three weeks from unit delivery.

**3.12 MISCELLANEOUS WORK**

Miscellaneous work is hereby defined as repair, refurbishment, or replacement of any other "Discovery Items" found during the disassembly inspection that were not included in the SOW or not otherwise covered in this standard. The Subcontractor is responsible for identifying to the Subcontract Administrator or their representative any recommended miscellaneous work and the associated cost to perform the work. This shall be documented on an RFI/DCN within 3 weeks from unit delivery. Upon approval by the Subcontract Administrator or their representative, of the Subcontractor's recommendation, the Subcontractor shall then proceed to accomplish the approved work consistent with related repair, refurbishment, or replacement requirements cited elsewhere in this standard. All discrepancies shall be recorded on Figure 18 (RFI) or Figure 23 (DCN). All changes to parts of the trailer/MSU that is under configuration control shall be documented on an RFI.

**3.13 ENGINEERING SERVICES**

The Subcontractor shall perform engineering on the trailers/MSUs as directed by the SOW and/or RFI/DCN. Approval to perform work will be given by the Subcontract Administrator or their representative.

4.0 **DISASSEMBLY OF TRAILER/MSU**

4.1 **MANIFOLD ASSEMBLY**

**NOTE**

*Components/fittings attached to the brass manifold on 100 Series MSUs are brazed in place and should not be removed.*

The Subcontractor shall generate sketches of the manifold assembly comprising tubing, fittings, and components. Each item in the sketch shall be identified using a progressive numerical system suitable for locating each item within the assembly. Photographs or video tape can be used to document overall manifold configuration prior to removal from the trailer/MSU. Each item (subassembly) within the manifold assembly shall be identified by a metal tag using the prefix of the trailer (GT) and storage unit (MSU) number and the suffix of the location number assigned as per the manifold assembly sketch. This identification shall ensure proper reassembly and will prevent similar, but different, components/sections from being interchanged causing installation problems. During removal of the manifold assembly, all cylinders shall be immediately plugged to maintain cleanliness.

**CAUTION**

*All cylinders shall be maintained dry internally at all times except when access to the inside of the cylinder is required (e.g., hydrostatic testing, internal cleaning, and internal drying). Any cylinder not being processed per the statement above, must be pressurized to approximately 25 +0, -10 psig with dry GN<sub>2</sub> meeting the requirements of Section 10.3.4. The cylinders shall be sealed with plugs and Schrader valves at all times. These precautions are required to prevent internal corrosion from taking place which could be detrimental to cylinder service life.*

**NOTE**

*If the trailer chassis is being replaced, with a new Contractor furnished chassis per Appendix E and the SOW, a new stainless steel manifold assembly shall be fabricated and installed per Appendix D and the SOW.*

## 4.2 CYLINDERS

All cylinders shall be completely removed from the trailer/MSU. Wire ropes, chains, or other metallic lifting devices, that may damage the cylinder coating and/or cylinder wall, shall not be used in direct contact with the cylinder. Special care shall be taken to prevent cylinder thread damage. The Subcontractor shall document cylinders by serial number and by location on the trailer/MSU, and complete Figure 11. See Figure 1 for cylinder configuration.

The Subcontractor shall remove all hardware on type I and VI trailers required to completely expose cylinder threads prior to inspecting and refurbishing the cylinders. On trailers other than types I and VI and on all MSUs, the Subcontractor shall remove hardware (to expose the cylinder threads prior to inspecting and refurbishing the cylinders) as directed by the SOW and/or as determined during the disassembly walkdown.

If cylinder backup nut removal is required, prior to removal of cylinder backup nuts and/or flanges, measure and record the distance (or the number of exposed threads) from the end of the cylinder for reassembly purposes.

The cylinders shall not be exposed to heat, fire, grinding, or other action which can affect wall thickness or material strength without written approval by the Subcontract Administrator, or their representative. The Subcontractor shall use appropriate heat indicating devices to ensure that the cylinders are not exposed to temperatures greater than 400°F.

### NOTE

*During cylinder manufacture, an end to end bow is induced due to the force of gravity acting on the cylinder in the molten state. This is known as the line of repose and the bow must go down when the cylinder is mounted between bulkheads. Cylinder manufacturers place an indentation at the neck area next to the end plug fittings indicating the up (12:00 position). Before disassembly, the Subcontractor shall permanently mark each cylinder (if not already marked) at the 12:00 position in such a manner that does not affect the structural integrity of the cylinder, to assure proper cylinder clearance at reassembly, for trailers with cylinder support saddles, and to preclude the potential for cylinder rotation to the low point. Cylinders and bulkheads shall be*

*marked in a manner that will establish the exact orientation of the cylinder on the trailer/MSU, as received. This alignment mark shall be used at reassembly.*

**4.3 CHASSIS**

Equipment that could be damaged during performance of this standard shall be protected by tape or total enclosure. Protection by removal is permitted for wheel assemblies. Bulkheads, cabinets, doors, and supports shall be removed if bolted to the frame. Chassis replacement shall be per Appendix E and as specified by the SOW.

**5.0 REASSEMBLY OF TRAILER/MSU**

**5.1 GENERAL**

After completion of test and refurbishment requirements specified herein, each component of the trailer/MSU shall be reinstalled in the same location it was in before disassembly, as documented by Figure 11 and Subcontractor generated sketches per paragraph 4.1, unless directed otherwise by the Subcontract Administrator or their representative. During reassembly, the Subcontractor shall document the location of each cylinder by serial number. The cylinder shall be returned to the location it was in before disassembly.

**5.2 DAMAGED SURFACES**

Surfaces damaged during reassembly shall be repaired in accordance with the following. The Subcontractor shall notify the Subcontract Administrator via RFI/DCN of such occurrences and provide the proposed corrective action.

- a. Surfaces with topcoat, tie-coat and primer missing shall be repaired in accordance with section A7.0 of Appendix A.
- b. Surfaces with damage to the finish coat only shall be repaired in accordance with section A8.0 of Appendix A.

**5.3 CYLINDER MOUNTING SPACER REPLACEMENT**

Belting type spacers between cylinders and under cylinder retaining straps shall be replaced with new, commercial grade, three-ply Citripak belting or approved equal. Dimensions of the new spacers shall cover



the entire width of the surface they are attached to and shall be sufficient to protect the cylinders from any metal to metal contact. In some cases it may be necessary to add multiple layers of the belting. Subcontractor shall provide belting. Belting installed on Type I, II and VI cylinder retaining straps shall be affixed with DAP Wellwood contact cement, USG Incorporated, or approved equal.

#### 5.4

#### SEALING

The Subcontractor shall seal airtight all faying surfaces and joints open less than 1/4 inch (including those created by cylinder installation). Sealant shall be per Federal Specification TT-S-230A, Type 2, and shall be gun-applied to the mating surfaces, except when space will not permit and application by spatula is required. Sealant shall be tooled after surfaces are mated to give a smooth appearance and total adhesion. Excess sealant shall be removed. The sealant material shall be applied to all metal-to-metal faying surfaces prior to reassembly of removed trailer items. Mating surfaces shall be sealed completely. All reflectors and light fixtures shall receive a coat of sealant on the back side of reflector frame prior to installation. The purpose of the sealant application is to eliminate potential areas of moisture entrapment on items that have been removed and reinstalled. For this reason, faying surfaces whenever possible shall have the outer surface of the joint sealed in a manner that places the sealant within the line of the joint (i.e. penetrates into joint). This is considered the most desirable method of sealing as, due to joint flexing from trailer vibration, sealant applied only to the outer perimeter can tear or split or develop pinholes from aging or shrinkage allowing moisture penetration.

Joints which can "breathe" and are in a vertical plane are best left unsealed. This does not apply to any joint which has been determined to be an entrapment area, lies in a horizontal plane, or situations where capillary action can induce moisture into a joint.

The sealant shall be applied to the joint following the application of inorganic zinc on equipment with one coat inorganic zinc coating systems. For finish coated primers (or repair methods that do not utilize inorganic zinc primer), apply caulking after the epoxy intermediate coat. The bead shall have a smooth, uniform finish and shall be cured (tacky to touch) prior to finish coat application.

Sealant shall be applied around cylinder flanges and the interfaces with the bulkhead to prevent moisture intrusion which causes corrosion of the threads on the cylinder neck per Figure 24.

**5.5 REASSEMBLED TRAILER/MSU CONFIGURATION**

The Subcontractor shall verify and certify the reassembled trailer/MSU has the same configuration as shown on the configuration drawing and Subcontractor generated sketches or as directed by the Subcontract Administrator or their representative. Review of the schematic drawing is required for verification. Approved variations from original configuration shall be documented by Subcontractor generated redline drawings and RFI's.

**5.6 DOCUMENTATION**

The Subcontractor shall document reassembly of trailer/MSU by completion of Figures 9 and 11.

**6.0 REHABILITATION, INSPECTION & LUBRICATION OF TRAILER/CHASSIS**

**6.1 RESPONSIBILITY**

The Subcontractor shall be responsible for conducting inspections per section 3.11. RFI's (Figure 18) or DCN's (Figure 23) shall be used to document rejected items and the disposition (repair or replacement) shall be upon the approval of the Subcontract Administrator or their representative. Subcontractor has right to appeal Contractor recommendations but final disposition will be made by the Subcontract Administrator or their representative. Any items that are replaced shall be replaced with identical or approved equal items.

**6.2 REHABILITATION OF TRAILER**

The Subcontractor shall provide and install the following, on the trailer, in accordance with 6.2.1 through 6.2.8.

**6.2.1 GROUNDING REEL**

For trailers designated for oxygen or hydrogen service, the Subcontractor shall replace the existing static grounding reel. The new reel shall be

Part No. 700-50-R supplied by Ametek, Hunter Spring Div. Hatfield, PA. 19440 or approved equal. After installation a resistance reading shall be made between trailer frame and ground reel clamp with the cable fully extended from the ground reel. The maximum allowable resistance shall be 10 ohms. The edges of holes for reel installation shall be cleaned and primed with inorganic zinc primer per A5.3.2.2 prior to installation. Reel to frame interface faying edge shall be sealed per paragraph 5.4.

#### 6.2.2 FASTENERS AND NONMETALLIC GOODS

All items such as lock wires, lock washers, cotter pins, and similar locking devices together with all nonmetallic gaskets, seals, seats, diaphragms and rings shall be replaced with identical items by the Subcontractor. Existing cylinder spacer belting shall be replaced with Citripak belting, or approved equal, per paragraph 5.3. Fasteners used for reassembly shall be new 300 Series stainless steel (except 303) of the same size, quantity, grade and configuration as the fastener hardware previously removed during trailer disassembly (exceptions: original wheel lugs, if not defective, are to be reused). Carbon steel threaded rods used on cylinder tie-down straps shall be replaced with 300 series stainless steel (except 303) threaded rods. Structural bolts that require greater strength than stainless steel can provide shall be replaced with identical items i.e. same size, grade, quantity and configuration. All fasteners shall be torqued to the values as recommended by the fastener manufacturer. Stainless steel cylinder mounting bolts shall be reused if not defective. Defective stainless steel bolts shall be replaced with new stainless bolts of the same size and configuration. SST washers shall be placed under all bolts and nuts during reassembly to prevent damage to the coating system when the fasteners are torqued down.

#### 6.2.3 LIGHTS

Brake, tail, clearance, license plate, and direction signal light bulbs, lenses and fixtures shall be replaced by the Subcontractor. Final trailer lighting will be of a configuration which matches as received condition as long as it complies with the Motor Vehicle Code (49CFR 393). In case of conflicts the Motor Vehicle Code shall take precedence. Configuration changes must be approved by the Subcontract Administrator. All changes shall be approved by the System Maintenance Engineer. All light housings shall be of the moisture proof design suitable for conduit interface.

**6.2.4 WIRING, CONDUIT AND CONNECTIONS**

The Subcontractor shall replace wiring, conduit, and electrical system connections. All trailer wiring shall be in PVC conduit with all frame or cabinet penetrations insulated against chafing by either (1) placing Tygon (or equal) tubing over the conduit at point of penetration, or (2) placing grommet in cabinet or frame opening. All unneeded "J"-boxes and excess military wiring arrangements shall be removed from the trailer.

**6.2.5 WHEEL BEARINGS**

The Subcontractor shall remove the wheels and hubs and replace bearings, bearing races and inner and outer grease seals. Bearings shall be of the greased type and they shall be lubricated prior to installation.

**6.2.6 BRAKES**

The Subcontractor shall replace brake shoe linings and springs. Drums shall be turned, cups and actuators inspected and replaced as directed.

**6.2.7 AIR BRAKE SYSTEM**

The Subcontractor shall inspect and replace (as directed) lines, covers, and connections. All air hoses, maxi-brake chambers, filters and relay valves shall be replaced by the Subcontractor. Lubricate hose seals with silicon spray. All air hoses shall be protected from sandblast, prime and paint operations. Spring brake chambers shall be installed on all trailers. Hydrostat air tank, visually clean interior and paint in accordance with this standard.

**6.2.8 REFLECTORS**

The Subcontractor shall replace the reflectors in their original configuration as long as it complies with the Motor Vehicle Code (49CFR 393). In case of conflicts the Motor Vehicle Code shall take precedence.

**6.3 CHASSIS INSPECTION**

The Subcontractor shall document chassis inspection by the completion of Figure 13. The Subcontractor's inspection shall include but shall not be limited to the items specified in 6.3.1 through 6.3.12.

**6.3.1 SPRINGS**

The Subcontractor shall repair/replace each leaf spring assembly as directed by the SOW. Replacement is required if corrosion, coating delamination, or deflection is excessive. New or repaired springs shall not be painted, but shall be coated or dipped with a Ziebart or approved equal coating system.

**6.3.2 AXLES**

The Subcontractor shall inspect axles with an axle gage to determine if axles are bent or out of camber. The axle shall be replaced if the axle is out of tolerance as set by the manufacturer. If manufacturer is unknown, tolerances from axles made from similar materials and with similar dimensions shall be used. If worn axle alignment pins and caps are discovered, the entire assembly shall be replaced.

**6.3.3 WHEELS**

The Subcontractor shall inspect wheel retainers and rim for damage, failure, or potential failure. The Subcontractor shall repair or replace defective items as directed. Ensure wheel lugs are properly torqued after reassembly of wheels on the trailer.

**6.3.4 TIRES**

Care shall be taken to protect tires during blasting, painting, etc by covering and limiting the number of tires on the chassis during these operations to one on each side of the trailer.

**6.3.5 LANDING GEAR**

The Subcontractor shall inspect landing gear internally and externally for proper operation, damage, failure, or potential failure. Defective items shall be repaired or replaced as directed.

**6.3.6 RUNNING GEAR**

The Subcontractor shall inspect entire running gear for damage, failures, or potential failures. Defective items shall be repaired or replaced as directed. Prior to inspection, the areas to be inspected shall be cleaned by pressure cleaning or steam cleaning to remove lubrication and dirt.

**6.3.7 FRAME**

The Subcontractor shall inspect trailer frame for structural defects and corrosion. Any structural damage, failure or potential failure shall be reported to and dispositioned by the subcontract administrator. If installed, the subcontractor shall remove spare tire rack.

**6.3.8 MANIFOLD ASSEMBLY COMPARTMENT DOORS, HINGES AND LATCHES**

The Subcontractor shall inspect the manifold assembly compartment doors, locks, hinges, and latches for proper operation, damage, failure, or potential failure and repair or replace as directed. If installed, the subcontractor shall remove mailboxes from the inside of the compartments.

**6.3.9 FIFTH WHEEL AND KINGPIN**

The Subcontractor shall inspect the fifth wheel and kingpin for damage, corrosion, failure, or potential failure and repair or replace as directed. When the fifth wheel and kingpin cannot be properly maintained and inspected due to inadequate access, a bolt-on type fifth wheel and kingpin shall be installed. Fifth wheel/kingpin repair or replacement shall be specified in the SOW or via RFI.

**6.3.10 FENDERS**

The Subcontractor shall inspect fenders for structural defects and corrosion. Repair or replace as directed.

**6.3.11 BULKHEAD AND CYLINDER MOUNTING HARDWARE**

The Subcontractor shall inspect bulkheads and cylinder mounting hardware, such as the rods, flanges, and supports for structural defects and corrosion. Repair or replace as directed. When replacement is required, carbon steel parts shall be replaced with stainless steel.

**6.3.12 MANIFOLD ASSEMBLY COMPARTMENTS**

The Subcontractor shall inspect manifold assembly compartments for structural defects and corrosion. Repair or replace as directed.

6.4 LUBRICATION

**NOTE**

*All lubrication shall be accomplished after blasting due to potential for entrapment of abrasive material in lubricants applied to the trailer chassis and its components. All old lubrication shall be removed prior to application of new lubricant.*

The Subcontractor shall provide lubricant and lubricate the trailer in accordance with the following:

COMPONENT OR SECTION	LUBRICANT TYPE
Fifth Wheel	MIL-G-10924
Landing Gear	MIL-G-10924
Wheel Bearings, Axles	MIL-G-10924
Brake Cam Shaft	MIL-G-10924
Hinges	MIL-L-2104 SAE-30
Locks, Latches	MIL-L-2104 SAE-30

7.0 **CYLINDER/CHASSIS/BULKHEAD REFURBISHMENT**

7.1 RESPONSIBILITY

The Subcontractor shall refurbish (blast, clean, repair and paint) the trailer/MSU as authorized by the Subcontract Administrator or their representative. Normally, this authorization will follow the trailer/MSU disassembly walkdown inspection and are the basis of refurbishment requirements for the individual trailer/MSU. The Subcontractor shall document rejected items and the refurbishment on the applicable forms.

7.2 TRAILER/MSU REPAIR

Any metal framing, housing, covering, bracket, or support requiring repair or replacement shall be of the same design and material as previously existed on the trailer/MSU, unless a deviation is authorized by the Subcontract Administrator or their designated representative. All corners shall be rounded and all edges shall be ground smooth on any fabrication work. The Subcontractor shall drill drain holes (approximately

1/2 inch diameter) in panels, housing, or other locations to prevent an accumulation of water. Drilled holes shall not significantly reduce structural design strength. If work is done after the coating system has been applied to the trailer/MSU, the newly exposed metal shall be coated per Appendix A of this standard.

### 7.3 WELDING

#### 7.3.1 QUALIFICATION OF WELDING PROCEDURES AND WELDERS

Welders and procedures shall be qualified and certified to AWS D1.1 for welding of carbon steel and AWS D1.2 for aluminum. Certifications shall be submitted to the Subcontract Administrator or their representative prior to start of work.

#### 7.3.2 JOINT PREPARATION

Surfaces to be welded shall be free of rust, grease, oil, scale, dirt, protective coatings or other foreign matter. Joints shall be prepared by mechanical methods prior to welding.

#### 7.3.3 MATERIALS

All materials used in the welding processes shall be in accordance with AWS D1.1 for carbon steel or AWS D1.2 for aluminum and shall be stored so no degradation will result during storage. Welding rods, welding wire, and electrodes used in welding shall be capable of producing satisfactory welds when used by a qualified welder and shall have a composition suitable for producing welds conforming to the requirements specified herein.

#### 7.3.4 TACK WELDING

Tack welds shall be used as required and shall be in accordance with AWS D1.1 and D1.2. Tack welds shall be used only as a means to hold parts in place, the final weld will be continuous. Whenever possible, the tack welds shall be spaced symmetrically along or around the joint. Tack welds shall be of sufficient size and length to permit ease of subsequent welding, yet ensure holding of the parts in place without cracking of the tack welds. Chipping or grinding shall be done to smooth both ends of tack welds in with base metal. Tack welds which have cracked must be removed. Tack welds must be worked into the weld beads.



### 7.3.5 WELD BEADS

Weld beads shall be terminated to avoid critical areas of the weld. Assemblies shall be welded in the flat position whenever practical. In addition to meeting the code requirements, the back step and intermediate methods of welding shall be used to lessen warpage when necessary. Weld beads shall not terminate in inside corners or in other critical areas such as in changes of welding direction or sudden changes in section thickness. Corner welds may be fillet weld, butt weld, or a combination thereof. Weld joints shall be continuous to preclude moisture entrapment areas, i.e. no skip welding permitted. The outside of the joint shall blend smoothly with the adjacent metal and sufficient metal shall be added to provide a suitable fillet or reinforcement.

### 7.3.6 POSTWELD CLEANING

All welded assemblies shall be cleaned free of oxide, flux, or other foreign matter prior to final inspection.

### 7.3.7 INSPECTION REQUIREMENTS

Inspection of structural welds shall be in accordance with KSC-SPEC-Z-0004, Class B, magnetic particle or dye penetrant inspection. Nonstructural welds shall be inspected per KSC-SPEC-Z-0004, Class C, Visual. Defects shall not be in excess of those specified in Table 2 of this standard.

### 7.4 MANIFOLD ASSEMBLY REPAIR OR REPLACEMENT

Repair or replacement of SST super pressure cone type tubing shall be in compliance with manufacturer's standards and procedures. Subcontractor's procedure shall be submitted and approved prior to performing work. Repair or replacement of stainless steel flared type tubing shall be in compliance with KSC specification KSC-SPEC-Z-0008. Tubing shall conform to KSC specification KSC-SPEC-Z-0007. Both the operators and machines used to fabricate replacement tubing shall be certified to KSC-SPEC-Z-0008. If not installed, the subcontractor shall install one check valve upstream of the outlet port and another check valve downstream of the inlet port per the applicable drawing and as specified in the SOW. Check valves are CFE. All brazing shall be per

KSC-SPEC-Z-0005, Class A. Manifold assemblies shall be replaced per Appendix D of this Standard and as specified in the SOW.

## **8.0 CYLINDER VISUAL INSPECTION**

### **8.1 INSPECTION REQUIREMENT**

Cylinder visual inspection shall be performed after cylinders are removed from the trailer/MSU. Cylinders shall be inspected per CGA C-6, Standards for Visual Inspection of Compressed Gas Cylinders. Experience in cylinder inspection is an important factor in determining acceptability of a given cylinder for continued service. Only personnel with previous experience and DOT certification for inspecting Department of Transportation (DOT) cylinders shall make cylinder evaluation. Judgement must be used by the Subcontractor's inspector to recommend rejection or acceptance. The Subcontractor shall document the visual inspection on Figure 14. Defects shall be recorded using descriptive terms such as none, slight, excessive, acceptable, reject, etc. Actual measurements made shall be recorded as to type, size, and location as required by CGA C-6. Special measurements made shall be recorded and the equipment used for measuring shall be recorded. Each cylinder shall be subjected to visual examinations which include the following paragraphs. Defects, measurements and equipment used shall be recorded on Figure 14.

#### **8.1.1 INSPECTION EQUIPMENT**

Exterior corrosion, denting, bulging, gouges, cuts, or digs are normally measured by direct measurement with straight edges, scales, calipers, and depth gages. When measuring cuts, compensation shall be made for the upset metal so only actual depth of metal removed from cylinder wall is measured. Bulges, dents, and general corrosion areas shall be measured by comparing a series of circumferential measurements. A variety of commercial, ultrasonic devices are available that will detect suspected subsurface flaws and to measure the wall thickness. Magnetic particle or dye penetrant methods are acceptable. Lights and boroscopes are acceptable for internal inspections. All discrepancies shall be recorded on Figure 14.

#### **8.1.2 GENERAL CORROSION**

General corrosion covers considerable surface area and reduces structural strength. General corrosion is often accompanied by pitting.

The cylinder shall be rejected if the limits of CGA C-6 section 3.2.1 are exceeded.

**8.1.3 LINE CORROSION**

When pits are connected, or nearly connected, to other pits in a narrow band or line, such a pattern is called "line corrosion". This condition is more serious than isolated pits. The cylinder shall be rejected if the limits of CGA C-6 section 3.2.1 are exceeded.

**8.1.4 ISOLATED PITS**

Isolated pits are small cross section pits that do not effectively weaken the cylinder wall but are indicative of possible complete penetration and leakage. The cylinder shall be rejected if the limits of CGA C-6 section 3.2.1 are exceeded.

**8.1.5 DENTS**

Dents in cylinders are deformations caused by the cylinder coming in contact with a blunt object. Metal thickness is not materially impaired. The cylinder shall be rejected if the limits of CGA C-6 section 3.2.2 are exceeded.

**8.1.6 CUTS, DIGS OR GOUGES**

Cuts, digs, or gouges are deformations caused by contact with a sharp object causing cylinder metal to be cut or upset, decreasing wall thickness at that point. Cuts, digs, or gouges shall be measured with suitable depth gages. The cylinder shall be rejected if the limits of CGA C-6 section 3.2.3 are exceeded.

**8.1.7 BULGES**

Cylinders are manufactured with a symmetrical shape. Definite visible bulges are cause for rejection. The cylinder shall be rejected if the limits of CGA C-6 section 3.2.6 are exceeded.

**8.1.8 NECK DEFECTS**

Cylinder necks shall be examined for cracks, folds, and flaws in accordance with CGA C-6. The cylinder shall be rejected if the limits of CGA C-6 section 3.2.7 are exceeded.

**8.1.9 THREAD DEFECTS**

Each internal cylinder neck thread shall be examined. At the time of manufacture, cylinders have a specified number of full threads of proper form as required in applicable thread standards. Cylinders shall be rejected if the number of effective internal threads are materially reduced. Gages shall be used to measure the number of effective, internal threads. Common thread defects are worn or corroded crest and broken, nicked, or cut threads. The cylinder threads are listed in Appendix F.

**8.1.10 OTHER DEFECTS**

Noticeable distortions, fire damage, or leaks are cause for rejection. Typical roughness over the entire cylinder or parallel serrations the length of the cylinder may be discontinuities relating to the rolling, swaging, or extrusion manufacturing process and are not cause for rejection.

**8.2 INTERNAL INSPECTION**

**8.2.1 INITIAL INSPECTION**

Each cylinder shall be inspected internally from both ends for evidence of corrosion. A light shall be used to illuminate the interior wall. The light shall be of sufficient intensity to produce a luminous flux density of 50 (lm/ft<sup>2</sup>) minimum at the cylinder wall. A boroscope shall be used to examine areas that are hard to see from the cylinder ends.

**8.2.2 CYLINDER INTEGRITY INSPECTION**

Following cleaning operations, cylinders shall be inspected to ensure cylinder integrity has not been damaged (refer to paragraph 10.5.3 or 10.6.7).

**8.2.3 CORROSION**

Visually inspect each cylinder for evidence of corrosion. The cylinder shall be rejected if the limits of CGA-C6 section 3.2.1 are exceeded.

**9.0 HYDROSTATIC TESTING**

The cylinders shall be hydrostatically tested in accordance with Appendix B. Every effort must be made to ensure the time between hydrostatic

test of the cylinders and delivery of the trailer/MSU to KSC does not exceed 30 days.

**10.0 CYLINDER CLEANING**

The cleaning method and materials listed in section 10 shall be used.

**10.1 RESPONSIBILITY**

The Subcontractor shall be responsible for ensuring each cylinder on a trailer/MSU meets visual inspection and sample analysis requirements prior to reassembling cylinders on the trailer/MSU.

**10.2 BASIC REQUIREMENTS**

**10.2.1 GENERAL**

Each cylinder qualified for continued service by hydrostatic testing shall be cleaned internally.

**10.2.2 PRECLEANING SAMPLING ANALYSIS**

The Subcontractor shall perform precleaning sample analysis on cylinders per section 3.4. The sampling is to be performed prior to any hydrostatic testing, inspections or other operations that may affect the cylinder interior. The sampling of the cleanliness level prior to cleaning is for historical data purposes. The procedure for precleaning sampling is detailed in section 10.5.4 (except that no flushing/rinsing is allowed before sample collection) and the analysis procedures are detailed in sections 14.1 and 14.2. Precleaning analysis shall be documented on Figure 12 and the Subcontractor shall provide the millipore sample pads to KSC in the documentation package at the time of trailer/MSU delivery.

**10.2.3 EQUIPMENT CONFIGURATION**

A suggested cleaning equipment set up showing minimum requirements is shown in Figure 2. Other configurations can be used with the approval of the Subcontract Administrator or their representative.

**10.2.4 POSITION OF CYLINDER**

Cylinders shall be internally cleaned and sampled in a vertical position.

**10.2.5      TECHNIQUES**

Series or parallel full flow, closed-loop, circulating, cleaning and flushing techniques shall be used. Spray cleaning is permitted if provisions are made to impinge the entire interior surface with the cleaning solution.

**10.2.6      INSPECTION REQUIREMENTS**

After the chemical cleaning phase, each cylinder shall be visually inspected internally and externally per section 8.0 of this standard to determine that cylinder integrity has not been damaged during cleaning operations.

**10.2.7      CLEANLINESS REQUIREMENTS**

The Subcontractor shall document and certify the cleanliness of each cylinder on Figure 16. Failure to meet the visual inspection requirements for particulate population limits or nonvolatile residue (NVR) shall be cause for rejection. Rejected cylinder(s) may be resampled. See sections 14.1 and 14.2 for sample procedure requirements.

**10.2.8      PARTICULATE ANALYSIS**

Particulate population and size ranges per square foot of internal surface area shall not exceed the limits specified in section 14.1 when sampled in accordance with that section.

**10.2.9      NONVOLATILE RESIDUE**

NVR analysis result shall not exceed the limits specified in section 14.2k when sampled in accordance with section 14.2.

**10.2.10     INTEGRITY REQUIREMENT**

The Subcontractor shall take the necessary precautions to maintain the cleanliness level following cleaning. This includes cleaning and sampling the Schrader type valves and cylinder plugs to a level equal to or greater than that required by sections 14.1 and 14.2 and ensuring that a GN<sub>2</sub> positive pressure is maintained during performance of subsequent work. The Subcontractor shall ensure cylinder internal threads are cleaned and dried to prevent flash rusting when reassembling the trailer/MSU. GN<sub>2</sub> used for pressurization shall be per section 10.3.4 and shall be sampled

to assure its particulate population is equal to or less than that established by section 14.1.

**10.3 CLEANING MATERIALS**

**10.3.1 BIODEGRADABLE DETERGENT**

Detergent, used in the cleaning process shall be biodegradable Turco 4215NC-LT, supplied by the Turco Corporation or approved equal.

**10.3.2 DEMINERALIZED WATER**

Demineralized water used in the flushing operation shall have a pH between 6.0 and 8.0 and shall be maintained at a minimum specific resistance of 50,000 ohms per centimeter. The demineralized water shall be checked daily for conformance to the requirements. The Subcontractor shall submit a sampling plan to the Subcontract Administrator or their representative for approval.

**10.3.3 ISOPROPYL ALCOHOL**

Isopropyl alcohol, used in the cleaning process, shall conform to Federal Specification TT-I-735A.

**10.3.4 NITROGEN**

GN<sub>2</sub>, used for drying, purging, or preservation shall conform, as a minimum, to Federal Specification BB-N-411C (Type I, Class I, Grade B), shall be filtered with a 25-micron absolute filter and shall have a maximum dewpoint of minus 65° F.

**10.3.5 OAKITE 33**

Oakite 33, used as an alternate to phosphoric acid in the cleaning process, shall be supplied by Oakite Products, Incorporated, 50 Valley Road, Berkeley Heights, New Jersey or approved equal.

**10.3.6 pH PAPER**

The pH paper, used for pH determinations, shall be supplied by Anachemia Chemical Limited, Montreal, Champlain, New York or approved equal.

10.3.7 PHOSPHORIC ACID

Phosphoric acid, used in the cleaning process, shall conform to Federal Specification O-O-670B.

10.3.8 SODIUM HYDROXIDE

Sodium hydroxide, used in the cleaning process, shall conform to Federal Specification O-S-598B.

10.3.9 SOLVENT

Trichlorotrifluoroethane conforming to Military Specification MIL-C-81302D, Type I, trichlorotrifluoroethane conforming to Johnson Space Center Specification MSC-SN-C-0037, or isopropyl alcohol conforming to the requirements of 10.3.3 shall be used as the flushing solvent. Before use, the solvent shall be sampled to assure the NVR is below 0.5 mg/ft<sup>2</sup>. This NVR shall be used as the base for determining the NVR results of the cylinder sample. Refer to section 14.2 for NVR analysis procedure. During use, all the solvent shall be filtered with a 10-micron absolute filter and shall be sampled and analyzed for NVR.

10.4 CLEANING EQUIPMENT

The following requirements shall be for equipment selection and facility development. Refer to Figure 2 for recommended schematic.

- a. Circulating pump shall be capable of sustaining flow against the pressure losses of the system. The minimum velocity for cleaning fluid shall be 4 feet/second.
- b. Pressure gages shall be selected so that the operating pressure falls within the middle two-thirds of the gage and shall be accurate to 1/2 percent of full scale.
- c. Hand valves and other components shall be of sufficient size and capacity to minimize pressure drop.
- d. Containers shall have sufficient capacity to fill the system being cleaned, prevent pump cavitation, and cover the heater elements in the containers.



- e. Heating equipment shall have sufficient capacity to control and maintain the temperatures required.
- f. Filters shall be installed and be capable of maintaining the cleanliness levels specified in section 14.1.
- g. The flow system shall have provisions for sampling downstream and upstream of the cylinder(s) and downstream of filters and pump(s).
- h. The equipment shall be arranged and the drains located so there is no pocket of stagnant fluid that cannot be drained following each sequence of the cleaning.
- i. The solvent system shall be separate from the chemical system.
- j. The chemical system shall be designed to permit a circulation process such that all of the cylinder internal surface area is exposed to the chemical in equal amounts of time and concentrations.

#### 10.5 CLEANING METHOD NO. 1

This is the approved method for cleaning lined carbon steel cylinders.

##### 10.5.1 SOLVENT FLUSHING

Cylinder(s) shall be subjected to a uniform internal solvent flush. Solvent flush shall be at a minimum velocity of 4 feet/second for one hour duration minimum, or until preliminary evaluation of solvent indicates cylinder is clean enough to perform sampling. After flushing, drain cylinder(s).

##### 10.5.2 INITIAL DRYING

Each cylinder shall be dried in a vertical position. A GN<sub>2</sub> purge shall be maintained in each cylinder until the effluent GN<sub>2</sub> reaches a dewpoint of 0° F. After final drying, the effluent GN<sub>2</sub> shall meet the dew point requirements of section 10.3.4.

10.5.3 INTERNAL INSPECTION

The interior of each cylinder shall be visually inspected in accordance with section 8.2 of this standard. Precautions shall be taken to prevent contamination from the use of the inspection light or boroscope. This inspection shall show no evidence of scale, corrosion residue or damage to cylinder liner. The cylinder shall be recleaned in accordance with section 10.5 if contamination is present inside the cylinder.

10.5.4 SAMPLING FOR CLEANLINESS LEVEL DETERMINATION

10.5.4.1 SOLVENT FLUSH

Each cylinder that meets the requirements of paragraph 10.5.3 shall be solvent flushed in a vertical position. Solvent used in the flushing process shall enter the cylinder through piping designed to give full spray coverage over the entire internal surface. After 30 minutes of flushing, spray each cylinder's interior with a measured amount of solvent (maximum 100 ml/ft<sup>2</sup> of internal surface area).

10.5.4.2 SAMPLING REQUIREMENT

Collect a 500-ml sample of the solvent flush. Sample shall be representative and shall be collected at the end of spraying operation.

10.5.4.3 ANALYSIS REQUIREMENT

Analyze solvent sample according to sections 14.1 and 14.2. A GN<sub>2</sub> purge or blanket shall be maintained in cylinders while awaiting sample results. Any cylinder failing to meet the cleanliness requirements shall be reflashed and resampled.

10.6 CLEANING METHOD NO. 2

This is the approved method for cleaning unlined carbon steel cylinders.

10.6.1 DEGREASING

Degrease cylinder(s) internally with a solution of 10 ± 2 percent sodium hydroxide, or approved equal, by weight and 0.01 ± 0.002 percent by weight nonionic detergent in potable water. Temperature of solution shall be maintained at 150° ± 10° F. Contact time will be 1 hour minimum.

10.6.2 WATER RINSE

Degreasing shall be followed by a rinse with potable water at  $140^{\circ} \pm 10^{\circ}$  F until the pH level of effluent water equals the pH level of influent potable water. After rinse, purge residual water from cylinder using  $\text{GN}_2$ .

10.6.3 WATER SCOURING

The cylinders may be degreased and derusted using high pressure water as an alternate to the chemical methods. The equipment shall be capable of flowing 12 G.P.M. at 10,000 psig. The cylinder shall be traversed from top to bottom with high pressure water for a minimum of 10 minutes. Water shall be filtered through a one micron filter. No matter which method is chosen the cylinders must be passivated per paragraph 10.6.4

10.6.4 DERUSTING AND PASSIVATION

Circulate a  $20 \pm 2$  percent by weight solution of phosphoric acid or an Oakite 33 solution,  $50 \pm 5$  percent by volume, through cylinder. Circulation time shall be from 20 minutes minimum to 1 hour maximum. Drain phosphoric acid or Oakite solution from cylinder.

10.6.5 ALCOHOL RINSE

Immediately rinse the interior of each cylinder with isopropyl alcohol. Ensure all internal surfaces are wetted by the isopropyl alcohol. As a safety precaution, cylinder should be purged with  $\text{GN}_2$  before inspection with lighting apparatus.

10.6.6 INITIAL DRYING

Each cylinder shall be dried in a vertical position. A  $\text{GN}_2$  purge shall be maintained in each cylinder until the nitrogen at the effluent point reaches a dewpoint of 0 degrees F. After final drying, the effluent shall meet the dew point requirements of section 10.3.4

10.6.7 INTERNAL INSPECTION

The interior of each cylinder shall be visually inspected in accordance with section 8.2. Precautions shall be taken to prevent contamination from use of the inspection light or boroscope. The cylinder shall be

re-cleaned according to section 10.6 if contamination is present inside the cylinder. Scale-free discoloration and passivation residues are permitted.

**10.6.8 SAMPLING FOR CLEANLINESS LEVEL DETERMINATION**

Sample and analyze per section 10.5.4

**10.7 DRYING AND SEALING CYLINDER**

Drying and sealing of a cylinder shall be performed as listed in paragraphs 10.7.1 through 10.7.4 regardless of cleaning method used. Special attention shall be given to ensure the ends of the cylinders are clean.

**10.7.1 CYLINDER DRYING**

Upon completion of cleaning level requirements, each cylinder shall be dried with GN<sub>2</sub> until effluent dewpoint meets the requirements of section 10.3.4. The cylinder shall be dried in a vertical position. Periodic checks of the dewpoint shall be made during trailer/MSU processing to ensure adequate GN<sub>2</sub> purge and sampling procedures are implemented to verify dewpoint readings are in fact representative of the cylinder internal condition.

**10.7.2 CYLINDER PLUG BACKUP RING AND O-RING REPLACEMENT**

Backup rings and O-rings on cylinder neck plugs on type II through V and VIII through IX trailers shall be replaced with new rings which have been cleaned to meet the particulate, fiber and NVR requirements of sections 14.1 and 14.2. The neck plugs on 100 series MSU's are brazed and shall not be removed unless directed by the SOW. The cylinder flange gaskets on 200 series MSU's shall be replaced with new gaskets which have been cleaned to meet the NVR requirements of sections 14.1 and 14.2. Precautions shall be taken to prevent contamination of the cylinder, plug(s) and ring(s) during installation. Caution must be exercised to ensure rings are not damaged during installation.

**10.7.3 CYLINDER TORQUE VALUES**

The Subcontractor shall utilize manufacturer's recommended torquing pattern and values and shall document their use, and the calibrated torque tool tracking number, on Figure 18.

**10.7.4 SEALING AND PRESERVATION**

Each cylinder shall be pressurized to  $25 \pm 10$  psig with  $GN_2$ . This shall be accomplished by using a Schrader type valve in one of the cylinder outlet plugs. The Schrader valves shall be provided by and cleaned by the Subcontractor. Cylinder plugs shall be cleaned and dried by the Subcontractor and shall be lubricated with Krytox 240 AC (DuPont Corporation, Wilmington, Delaware) or approved equal prior to cylinder sealing.

**10.7.5 INTEGRITY CONTROL REQUIREMENT**

Failure to maintain a pressure of  $25 +0, -10$  psig on a cylinder during performance of subsequent work will require the cylinder to be resampled per section 10.5.4. Any cylinder failing to meet the cleanliness requirements shall be reflashed and resampled. The Subcontractor shall investigate any incident involving uncontrolled loss of pressure (below  $25 +0, -10$  psig) on a cylinder and shall provide the Subcontract Administrator with the proposed corrective action.

**11.0 TESTING OF MANIFOLD ASSEMBLIES**

**11.1 HYDROSTATIC TEST OF MANIFOLD ASSEMBLIES**

The Subcontractor shall hydrostatically test the manifold assembly piping, tubing, and hand valves prior to rehabilitation. The Subcontractor shall take necessary precautions to perform testing requirements safely. Hydrostatic testing of the manifold assembly may be performed prior to removal from the trailer/MSU provided that all components that may be damaged are protected (or removed). Subsequent processing, repair, or other action that may invalidate the test will require retest of the component(s) affected. The manifold assembly piping, tubing, and components shall be supported in such a manner that will prevent them from getting damaged during testing.

**11.1.1 PRESSURE REQUIREMENT**

Hand valves, existing tubing, and piping shall be hydrostatically tested to one and one half times the working pressure of the cylinder. See Table 1 for applicable working pressure. New flared tubing shall be hydrostatically tested per KSC-SPEC-Z-0008C, Table 7.

11.1.2 TEST PROCEDURE

- a. Connect test specimen to hydrostatic pressure apparatus and torque fittings as applicable.
- b. Flow water through test specimen until water is clear of air bubbles at effluent.
- c. Dead end test specimen as applicable. Start pressure source and increase water supply pressure to the test pressure.
- d. Maintain test pressure for a minimum of 1 minute. Release test pressure prior to removing test specimen.

11.1.3 ACCEPTANCE REQUIREMENT

The test specimen under test pressure shall be visually checked for leakage, rupture, or distortion. No evidence of leakage, distortion, or rupture is permitted for acceptance. Record the results on Figure 17.

11.2 FUNCTIONAL TEST OF MANIFOLD ASSEMBLY

Components of the manifold assembly shall be functionally tested after rehabilitation and cleaning. Leak detection compound, used in functional testing, shall conform, to Specification MIL-L-25567D. The GN<sub>2</sub> used in functional testing shall conform as a minimum to Federal Specification BB-N-411C and shall be filtered through a 25-micron minimum absolute filter . Trailer/MSUs in helium service shall be leak checked with 10% GHe.

GN<sub>2</sub>/GHe used for testing shall be analyzed by aerosol technique to validate particulate levels are well below the limits established by section 14.1 to prevent contamination of the test specimen. The functional test apparatus shall not contaminate the test specimen.

Tubing and test fixtures used in the test of the specimen shall meet or exceed the cleanliness requirements of sections 14.1 and 14.2.

11.2.1 FUNCTIONAL TEST OF HAND VALVES

See Figure 4 for test equipment setup.

### 11.2.1.1 TEST PROCEDURE

The functional test for hand valves is as follows.

- a. Install hand valve in test setup as shown in Figure 4.
- b. Close all hand valves and test specimen. Open HV-1 and adjust GN<sub>2</sub> source to test pressure indicated on gage PG-1 by adjusting regulator R-1. See Table 1 for working pressure for cylinders. This is the test pressure for hand valves. Check for leaks in test setup.
- c. Open HV-3 and check for leakage. No leakage is allowed during a 1 minute duration.
- d. Close HV-3 and open test specimen. Monitor gage PG-2 to ensure test specimen is open. Check for leakage at stem, gland, and body. No leakage is allowed during a 1 minute duration.
- e. Cycle (closed to open to closed) test specimen three times and stop in the closed position. Remove flex hose from beaker of water. Open HV-3 and vent pressure to atmosphere. Reinsert flex hose into beaker of water and leave valve HV-3 open. Check for leakage. No leakage is allowed during a 1 minute duration hold.
- f. Repeat paragraphs "b" through "e" two times.
- g. Close valve HV-1. Open valve HV-2 and vent pressure to atmospheric pressure. Remove test specimen. Reverse the direction of flow of the test specimen and repeat paragraphs "a" through "f" inclusive.

### 11.2.2 FUNCTIONAL TEST OF REGULATORS

See Figure 5 for test equipment setup.

#### 11.2.2.1 TEST PROCEDURE

The following procedure is applicable for Type III through IX trailers.

- a. Mount test specimen as shown in Figure 5. Close all valves and regulators.
- b. Adjust test specimen to the full closed position.

- c. Open valves HV-1 and HV-5.
- d. Adjust regulator R-1 until gages PG-1 and PG-2 indicate 100 percent of maximum rated inlet pressure of test specimen.
- e. Leak check specimen for external leakage and any discharge of valve HV-5 for internal leakage. No leakage is permitted.
- f. Close valve HV-5.
- g. Adjust specimen until gage PG-3 indicates 25 percent of maximum rated outlet pressure.
- h. Externally leak check test specimen. No leakage is permitted.
- i. Repeat paragraphs "g" and "h" at 100 percent of maximum rated outlet pressure.
- j. Adjust test specimen to full closed position.
- k. Vent system by opening valve HV-5, then closing valve HV-5.
- l. Adjust test specimen until PG-3 indicates 25 percent of maximum outlet pressure. Record pressure on Figure 17.
- m. Remove flex hose from beaker. Cycle valve HV-5 (open to closed to open), five times. Gage PG-3 shall return to pressure indicated in paragraph "l"  $\pm$  2 percent. No creepage is allowed. Record pressure on Figure 17.
- n. Slowly open valve HV-2 and adjust regulator R-2 until relief in test specimen cracks. Record pressure, at point of hesitation or decay on gage PG-3, on Figure 17. This is the cracking pressure. Cracking pressure is 120 percent of outlet (set) pressure (maximum). Make relief setting adjustment at this point, if applicable.
- o. Close valve HV-2 and record reseal pressure, point where pressure drop ceases on gage PG-3, on Figure 17. Reseal pressure shall be 88 percent of cracking pressure (minimum).



- p. Repeat paragraphs "l" through "o" with test specimen set at 50 percent, 75 percent and 100 percent of maximum rated outlet pressure. Record all results on Figure 17.
- q. Adjust test specimen to 25 percent of rated outlet pressure. Relief valve shall reseal and not have a constant bleed. Record results on Figure 17.
- r. Adjust test specimen and regulator R-1 and R-2 to fully closed. Open vent valves HV-4 and HV-5 and remove test specimen.

### 11.2.3 FUNCTIONAL TEST OF DOME LOADED REGULATORS

See Figure 6 for test equipment setup.

#### 11.2.3.1 TEST PROCEDURE

The following test procedure is applicable for Type III through IX, exclusive of Type VI, trailers.

- a. Mount test specimen as shown in Figure 6. Close all valves and regulators.
- b. Open valves HV-1 and HV-6. Slowly increase pressure to 100 percent of maximum rated inlet pressure by adjusting regulator R-1. Leak check all body joints and connections for external leakage and discharge of valve HV-6 for internal leakage. No leakage is allowed.
- c. Close valve HV-6. Open valves HV-3 and HV-5. Check for leakage past diaphragm at HV-5. No leakage allowed. Caution shall be used to ensure pressure does not exceed rated outlet pressure.
- d. Vent system by closing valve HV-1 and cycling (open to closed to open) valves HV-4, HV-5 and HV-6.
- e. Close valves HV-3, HV-4, HV-5 and HV-6. Open valves HV-1 and HV-2. Increase regulator R-1 to 100 percent of maximum inlet pressure to inlet of test specimen.

- f. Increase pressure to dome with regulator R-2 until gage PG-3 indicates 25 percent of maximum rated outlet pressure. Record gage PG-3 indication on Figure 17.
- g. Cycle valve HV-6 (open to closed to open) five times. Verify gage PG-3 returns to pressure indicated in paragraph "f"  $\pm$  2 percent.
- h. Repeat paragraphs "f" and "g" with pressures of 50, 75 and 100 percent of maximum rated outlet pressures. Record gage PG-3 indications at 50, 75 and 100 percent settings on Figure 17.
- i. Repeat paragraphs "b" through "h" two times.
- j. Close regulator R-1. Open valves HV-4, HV-5 and HV-6 and vent system. Remove test specimen and close all valves and regulator R-2.

#### 11.2.4 FUNCTIONAL TEST OF RELIEF VALVES

See Figure 7 for test equipment setup. The Subcontractor shall perform functional test and make any necessary adjustments to ensure the set pressures and tolerances listed in Table 1 are met.

##### 11.2.4.1 TEST PROCEDURE

The following procedure is applicable to Type III through IX and Type I hydrogen trailers.

- a. Mount test specimen as shown in Figure 7. Close regulator R-1 and valve HV-2.
- b. Open valve HV-1 and slowly adjust pressure regulator R-1 until test specimen cracks (begins bubbling). This is cracking pressure as defined in this standard. Valve shall not crack at less than 95% of set pressure. Record relief pressure, indicated on PG-1, on Figure 17. Compare result obtained with desired set pressure from Table 1.
- c. Make relief adjustments at this point, if necessary. Vent test pressure prior to making any adjustments to relief valve. If it is necessary to remove cap to make relief adjustments, replace cap after each trial adjustment. Failure to replace cap will result in an improper relief setting.

- d. Decrease pressure until specimen reseats bubble tight. Reseat pressure shall be 92% of set pressure (minimum). The maximum allowable leakage is 6 cc per minute (cc/min) at reseat pressure for relief valves with metal-to-metal seats and 0 cc/min for relief valves with soft seats. Record results on Figure 17. Reseat pressure must always be above cylinder working pressure.
- e. Close regulator R-1 and valve HV-1 and vent test specimen by opening valve HV-2.
- f. Close valve HV-2, then open valve HV-1 and adjust regulator R-1 and slowly increase pressure until PG-1 reaches cylinder working pressure and check for seat leakage. No leakage is permitted for relief valves with soft seats. The allowable leakage for relief valves with metal-to-metal seats is 6 cc/min. Record results on Figure 17.
- g. Close regulator R-1 and open valve HV-2 and vent test specimen. Remove test specimen.

## 11.2.5 FUNCTIONAL TEST OF PRESSURE GAGES

Refer to Figure 8 for test equipment setup.

### 11.2.5.1 REQUIREMENT

The maximum allowable tolerance for pressure gages shall be  $\pm 2$  percent of full scale.

### 11.2.5.2 TEST PROCEDURE

The following procedure is applicable for Type I through IX trailers and MSU's.

- a. Mount test specimen as shown in Figure 8.
- b. Cycle test specimen from 0 psig to full scale at least 2 times by adjusting regulator R-1 prior to checking indications. Vent system to atmospheric pressure through valve HV-1 between each cycle.
- c. Verify 0 psig indication on test specimen with regulator R-1 closed and vent valve HV-1 open. Adjust test specimen according to manufacturer's recommendations, if necessary.

- d. Close valve HV-1. Adjust regulator R-1 and record the indications of test standard PG-1 and test specimen PG-2 at 0, 25, 50, 75, 100, 75, 50, 25 and 0 percent of full scale on Figure 17.
- e. Repeat paragraph "d" if any adjustments are made.
- f. Close regulator R-1 and open valve HV-1 and vent pressure.
- g. Remove test specimen.

#### 11.2.6 FUNCTIONAL TEST OF OUTLET CHECK VALVES

See Figure 7 for test equipment setup. The Subcontractor shall perform functional test to ensure the check valves reseal at a pressure no lower than 200 psig (reseal setting is  $250 \pm 50$  psig). Check valves that do not meet the requirements of this section shall be replaced.

##### 11.2.6.1 TEST PROCEDURE

The following procedure is applicable to all trailers/MSU's with outlet check valves installed.

- a. Mount test specimen as shown in Figure 7. Close regulator R-1 and valve HV-2.
- b. Open valve HV-1 and slowly adjust pressure regulator R-1 until test specimen cracks (begins bubbling). Valve shall not crack at less than 200 psig. Record pressure, indicated on PG-1, on Figure 17.
- c. Decrease pressure until specimen reseats bubble tight. Reseat pressure shall not be less than 200 psig. Record results on Figure 17.
- d. Close regulator R-1 and valve HV-1 and vent test specimen by opening valve HV-2.
- e. Remove test specimen.

#### 11.2.7 FUNCTIONAL TEST OF INLET CHECK VALVES

The Subcontractor shall perform a functional test on the check valves to ensure proper operation. The following two tests shall be performed.

- a. A flow test in the proper flow direction (using GN<sub>2</sub> conforming to the requirements of Section 10.3.4). The check valves shall meet the flow requirements listed by the manufacturer's specification.
- b. A leak check (using GN<sub>2</sub> conforming to the requirements of Section 10.3.4) shall be performed in the opposite direction from normal flow to ensure the check valve reseats properly. No evidence of leakage is permitted.

### 11.3 LEAK TEST OF MANIFOLD ASSEMBLY

The Subcontractor shall perform a pressure test on the manifold assembly and check for leakage. This test shall be performed after reassembly of the manifold assembly and connection to cylinders. A pressure of 25 +0, -10 psig, shall remain in the trailer/MSU.

#### 11.3.1 REQUIREMENT

No evidence of leakage is permitted when leak detection solution conforming to Federal Specification MIL-L-25567D is applied to each tube-to-pipe joint, tube-to-pipe fitting and components. The leak check shall be performed with GN<sub>2</sub> conforming to the requirements of Section 10.3.4. The GN<sub>2</sub> shall be filtered through a 25-micron absolute filter. Trailers/MSU in helium service shall be leak checked with 10% GHe (also filtered through a 25-micron absolute filter). The exterior of the manifold assembly shall be rinsed with Demineralized water after the leak test.

#### 11.3.2 PROCEDURE

##### NOTE

*Individual cylinder systems may be tested separately to conserve GN<sub>2</sub> and permit gas cascading.*

- a. Connect a regulated GN<sub>2</sub> source to fill port of trailer/MSU.
- b. Ensure all gage and cylinder valves and other manifold assembly valves and regulator(s) are open and all valves that discharge to atmosphere are closed.
- c. Open GN<sub>2</sub> source and apply 10 percent of the cylinder working pressure (refer to Table 1) to the manifold assembly and cylinders.

Perform leak check evaluation including burst disks and relief valves. Vent pressure and repair leaks as necessary.

- d. Repeat (c) at 100 percent of working pressure (refer to Table 1). No leakage is allowed. Record the result of the leak check on Figure 17.
- e. Reduce pressure in cylinder(s) to 25 +0, -10 psig. Close all valves and regulators including cylinder valves. Disconnect GN<sub>2</sub> source and seal inlet, discharge and vent ports, on the trailer/MSU, with Quality Assurance (QA) seals.

#### 11.4 DOCUMENTATION

The Subcontractor shall document the testing of the manifold assembly on Figure 17.

#### 12.0 REHABILITATION OF MANIFOLD ASSEMBLY

##### 12.1 BASIC REQUIREMENT

The Subcontractor shall rehabilitate (restore) and mark each component within the manifold assembly.

##### 12.2 DISASSEMBLY OF COMPONENTS

Each component shall be disassembled per specific manufacturer's instructions. The Subcontractor shall be furnished component specifications or prints and manuals, as applicable, of the components by the BOC.

#### NOTE

*Components/fittings attached to the brass manifold assemblies on 100 Series MSUs are brazed in place and should not be removed.*

##### 12.3 REPLACEMENT ITEMS

The Subcontractor shall replace all component soft goods with new identical soft goods. The softgoods shall be ordered within three weeks of subcontract award per paragraph 3.11.1. The replacement soft goods shall be from the manufacturer of the component. Softgoods and lubricants used on trailers/MSUs in breathing air or oxygen service [or

capable of being changed to oxygen or breathing air service as indicated on the configuration drawing (see 2.0)] shall be certified by batch testing to be oxygen compatible per 79K09561 and NHB 8060.1. The Subcontractor shall provide material certifications, for the softgoods, as part of the data package. The Subcontractor shall replace all burst disks in the manifold assembly. No substitution of any replacement part is permitted without approval of the Subcontract Administrator or their representative. The trailers/MSUs are under strict configuration control by KSC. As some trailers/MSUs are in oxygen and hydrogen service and component compatibility is critical, adherence to no substitution without approval, is mandatory (refer to paragraph 15.2). New flared tubing shall be fabricated per KSC-SPEC-Z-0008C. All cylinder valves shall be Sherwood Selpac valves and the Subcontractor shall replace cylinder valves as required.

**NOTE**

*Nylon seats in components from Type I or II trailers shall be replaced with Kel-F seats. Component bodies shall be stamped with a "K" to designate that Kel-F seats have been installed.*

12.4 INSPECTION

The Subcontractor shall inspect each component of the manifold assembly for damage during walkdown and disassembly inspections. Damaged hardware shall be reported to the Subcontract Administrator or their representative and documented on Figure 18.

12.5 REPAIR

Hardware that has repairable damage shall be reworked by the Subcontractor as an integral part of this standard.

12.6 CLEANING

The Subcontractor shall clean each component of the manifold assembly, the manifold assembly itself and all related tubing according to section 13.

**NOTE**

*All cleaning, reassembly, and testing shall be accomplished in a totally enclosed area, environmentally controlled to the guideline requirements*

*of FED-STD-209, Class 5000. The Subcontractor shall perform daily analysis of room conditions to ensure compliance to specification requirements.*

## 12.7 REASSEMBLY OF COMPONENTS

The Contractor shall reassemble each cleaned component according to contractor supplied component specifications or manufacturer's instructions. The cleanliness level shall not be degraded during reassembly. Any component requiring lubrication shall be lubricated with Krytox 240 AC or approved equal. Teflon tape, per Federal Specification MIL-T-27730A, shall be used on pipe threads.

### 12.7.1 MARKING OF COMPONENTS

All components reworked per this standard shall be identified by means of a firmly attached weatherproof tag which is stamped, engraved or etched with the 81K drawing number and revision letter.

## 12.8 TESTING OF COMPONENTS

Components requiring functional testing shall be processed according to the applicable paragraph of section 11.2. Analysis of test media shall be performed each day of testing. The Subcontractor shall take precautions to ensure that test apparatus does not contaminate the test specimen.

The tubing, fixtures and components used in support of component testing shall meet or exceed the cleanliness requirements of sections 14.1 and 14.2.

## 12.9 SEALING

The inlet and outlet connection of each component that passes the functional test shall be sealed. The seal shall consist of a layer of Aclar film, over the openings, secured with a complete covering of pressure-sensitive tape and sealed with integrity control QA seals. The Aclar film shall conform to Military Specification MIL-B-22191D and shall meet or exceed the requirements of sections 14.1 and 14.2. The pressure-sensitive tape shall conform to Federal Specification PPP-T-66. The sealed items shall be placed in a polyethylene bag and stored until the component is installed in the manifold assembly.



**12.10 REASSEMBLY OF MANIFOLD ASSEMBLY**

The Subcontractor shall reassemble the manifold assembly & connect it to the cylinders in a totally enclosed building with a controlled environment. A polyethylene shroud utilizing a portable laminar flow bench is acceptable. Entry to this area shall be controlled and limited to those personnel necessary to accomplish the work. Personnel entering the area shall wear clean polyester smocks over their clothing. Smocks shall be cleaned and certified to the requirements of ASTM-F-51-68T and shall be in conformance with MSC-SPEC-C-2A. Tooling used shall be clean and free of any visual contamination. Extreme caution must be exercised and necessary precautions taken during reassembly of manifold assembly parts to ensure that those surfaces that come in contact with the trailer's/MSU's service media are not contaminated. A seemingly innocent thing such as a fingerprint, may be considered a serious contaminant particularly if the affected area is exposed to high-pressure oxygen.

**12.10.1 INTEGRITY OF CLEANLINESS LEVEL**

The integrity of each component's cleanliness level shall be verified by QA at time of reassembly by examination of the inlet and outlet sealing as required by paragraph 12.9. The sealing shall not have been disturbed, torn, ripped, or destroyed in any manner which may leave the component's cleanliness in doubt.

**12.10.2 MANIFOLD ASSEMBLY TORQUE VALUES**

The Subcontractor shall utilize manufacturer recommended values and shall document their use on Figure 17 in the data package.

**12.10.3 LUBRICATION OF MANIFOLD ASSEMBLY THREADS**

Use Krytox 240 AC, or approved equal, to lubricate tube-type threads and-apply 2 -3 layers of Teflon tape to pipe threads during reassembly of trailer/MSU manifold assemblies. The Teflon tape shall conform to Military Specification MIL-T-27730A. Lubrication shall be per KSC-SPEC-Z-0009.

**13.0 CLEANING OF MANIFOLD ASSEMBLIES**

**13.1 REQUIREMENTS**

The Subcontractor shall clean the manifold assembly piping and disassembled component parts. To verify cleanliness, solvent flush samples shall be analyzed in accordance with sections 14.1 and 14.2. Disassembled component parts shall be reassembled according to the manufacturer's instructions following verification of cleanliness level.

**13.2 CLEANING MATERIALS**

**13.2.1 BIODEGRADABLE DETERGENT**

Detergent, used in the cleaning process, shall be biodegradable Turco 4215NC-LT, or approved equal, supplied by the Turco Corporation.

**13.2.2 ISOPROPYL ALCOHOL**

Isopropyl alcohol, used in the cleaning process shall conform to the requirements of section 10.3.3.

**13.2.3 NITRIC ACID**

Nitric acid, used in the cleaning process, shall conform to Federal Specification O-N-350B.

**13.2.4 NITROGEN**

GN<sub>2</sub> used for drying, purging, or preservation shall conform to the requirements of section 10.3.4.

**13.2.5 OAKITE 33**

Oakite 33, used as an alternate to phosphoric acid in the cleaning process, shall be supplied by Oakite Products Incorporated, 50 Valley Road, Berkeley Heights, New Jersey or approved equal.

**13.2.6 pH PAPER**

The pH paper used for pH determinations shall be supplied by Anachemia Limited, Montreal, Champlain, New York or approved equal.

**13.2.7 PHOSPHORIC ACID**

Phosphoric acid, used in the cleaning process, shall conform to Federal Specification O-O-670B.

**13.2.8 SOLVENT**

Trichlorotrifluoroethane conforming to Military Specification MIL-C-81302D, Type I, trichlorotrifluoroethane conforming to Johnson Space Center Specification MSC-SN-C-0037, or isopropyl alcohol conforming to the requirements of 10.3.3 shall be used as the flushing solvent. During use, all the solvent shall be filtered with a 10-micron absolute filter and shall be sampled and analyzed for NVR. Before use the solvent shall be sampled to assure the NVR is below 0.5 mg/ft<sup>2</sup>. This NVR shall be used as the base for determining the NVR results of the cylinder sample. Refer to section 14.2 for NVR analysis procedure.

**13.3 CLEANING PROCEDURE FOR MANIFOLD ASSEMBLIES**

The following procedure applies to all manifold assembly piping, tubing, and disassembled component parts exclusive of pressure gages. Acid immersion, paragraph 13.3.4, and subsequent pertinent rinses may be deferred if visual inspection indicates cleanliness levels of sections 14.1 and 14.2 will be met. Pressure gages shall be cleaned in accordance with paragraph 13.9.

**13.3.1 DEGREASE**

Degrease the interior and exterior of manifold assembly piping, tubing, and component parts, in a caustic solution, sodium hydroxide or approved equal, for all materials except aluminum and soft goods. Solution concentration shall be 18 to 22 ounces per gallon and temperature shall be 140° to 160° F. Dwell time shall not exceed 1 hour. Proceed to acid immersion (paragraph 13.3.4) after an interim hot water rinse.

**13.3.2 DETERGENT CLEANING**

Scrub with a brush the interior and exterior of the manifold assembly piping, tubing, and component parts, including soft goods with a detergent solution containing 2 to 3 ounces of biodegradable detergent per gallon of demineralized water. The temperature of the detergent solution shall be maintained at 140° ± 10° degrees F during the scrubbing process.

13.3.3 INITIAL RINSE

Flush the manifold assembly piping, tubing, and component parts with demineralized water. All surface areas shall be wetted during the flushing process.

13.3.4 ACID IMMERSION

Immerse the manifold assembly piping, tubing, and component parts in accordance with the following

<b>TYPE MATERIAL</b>	<b>SOLUTION</b>	<b>DURATION</b>
Carbon Steel	Phosphoric acid, 20 ± 2 percent by weight, ambient temperature or Oakite 33 solution 50 percent by volume, ambient temperature	1 to 2 hours
Stainless Steel	Nitric acid, 32 ± 5 percent by weight, ambient temperature	1 to 2 hours
Copper, Brass or Bronze	Phosphoric acid, 20 ± 2 percent by weight, ambient temperature or Oakite 33 solution, 50 percent by volume ambient temperature	0.3 to 2 hours
Other materials (Including soft goods)	No acid immersion (detergent only)	None

13.3.5 FINAL RINSE

The type rinse to be used shall be determined by the type cleaning solution used.

CLEANING SOLUTION	RINSE
Phosphoric Acid	Alcohol
Oakite 33	Alcohol
Nitric Acid	Demineralized Water
Detergent	Demineralized Water

13.3.5.1 ALCOHOL RINSE

Rinse manifold assembly piping, tubing, and component parts cleaned with phosphoric acid or Oakite 33 with isopropyl alcohol to remove excess phosphoric acid.

13.3.5.2 WATER RINSE

Flush the manifold assembly piping, tubing, and component parts cleaned with detergent or nitric acid with demineralized water heated to a temperature of  $140^{\circ} \pm 10^{\circ}$  F. All surface areas shall be wetted during the flushing process. After flushing each surface shall be checked for a pH reading between 6.0 and 8.0. Manifold assembly piping, tubing, or component parts that do not meet the pH requirement shall be reflashed and rechecked.

13.4 INITIAL DRYING

Dry the interior and exterior of all manifold assembly piping, tubing, and component parts with  $GN_2$ .

13.5 INITIAL INSPECTION

The interior and exterior of all manifold assembly piping, tubing, and component parts shall be visually inspected and shall have no visible contamination.

13.6 SOLVENT FLUSH AND TESTING

Solvent flush the interior and exterior of all manifold assembly piping, tubing, and component parts which come in contact with the service gas

media. After flushing, sample flush the manifold assembly piping, tubing, and component parts with solvent (100 ml/ft<sup>2</sup> of surface area) and collect a representative sample of the flush solvent. Analyze the sample in accordance with sections 14.1 and 14.2. If grouping fails to meet the cleanliness requirement, the grouping shall be reflashed and resampled.

### 13.7 FINAL DRYING

The interior and exterior of manifold assembly piping, tubing, and component parts shall be dried with GN<sub>2</sub>. The GN<sub>2</sub> shall not contaminate the cleaned manifold assembly piping, tubing, or component parts. The components shall be dried until the effluent GN<sub>2</sub> has a maximum dew-point of minus 65° F.

### 13.8 SEALING

Small, cleaned components (after reassembly of parts) shall be sealed according to paragraph 12.9. If applicable, sealing shall follow functional testing (section 11.2). Tubing and items not requiring functional test shall be sealed with a layer of Aclar film, conforming to Military Specification MIL-B-22191D, that meets or exceeds the cleanliness requirements of sections 14.1 and 14.2, over the openings secured with a complete covering of pressure-sensitive tape and sealed with integrity control QA seals. The tape shall conform to Federal Specification PPP-T-66. The Aclar layer shall be overwrapped with polyethylene film and taped.

### 13.9 CLEANING PROCEDURE FOR PRESSURE GAGES

This procedure is applicable to pressure gages only. Gages shall not be disassembled for cleaning.

#### 13.9.1 GAGE EXTERIOR

The exterior of the pressure gages shall be wiped clean with a dust-free cloth saturated with a detergent solution containing 2 to 3 ounces of biodegradable detergent per gallon of demineralized water. Sampling of gage's exterior is not required.

#### 13.9.2 GAGE INTERIOR

The interior of pressure gage bourdon tubes shall be cleaned and sampled. The sample shall be analyzed in accordance with sections 14.1 and 14.2.

**13.9.2.1 GAGES WITH BLEED PORTS**

Solvent shall be flushed through bourdon tube from bleed port to inlet and from inlet to bleed port. After flushing, a sample of flush solvent shall be collected and analyzed in accordance with sections 14.1 and 14.2. Sample will represent one fourth of a square foot of surface area. Solvent flushing shall be continued until satisfactory results are obtained.

**13.9.2.2 GAGES WITHOUT BLEED PORTS**

Solvent shall be flushed into bourdon tubes without bleed ports and solvent removed by vacuum. Syringe method is acceptable. The filling and vacuuming process shall be repeated a minimum of 5 times. The solvent flush shall represent one fourth of a square foot of surface area and shall be analyzed, in accordance with sections 14.1 and 14.2, to verify cleanliness. Solvent flushing and vacuum operations shall be continued until satisfactory results are obtained.

**13.9.3 DRYING**

Dry pressure gages with  $\text{GN}_2$ . The  $\text{GN}_2$  shall not contaminate the cleaned gages.

**14.0 SAMPLE ANALYSIS PROCEDURES**

**14.1 PARTICULATE ANALYSIS PROCEDURE**

The following procedure shall be used to determine the particulate size and population.

- a. If the sample is a presample and requires a total filterable solids (TFS) determination perform steps (b) through (f).
- b. Preweigh filter pad to nearest 0.1 milligram on a balance calibrated on a yearly basis.
- c. Analyze per steps g through l below. If pad is silted, record as too numerous to count (TNTC).
- d. Reweigh filter pad with collected particulate matter undisturbed and in place.

- e. The difference in initial and final weight is TFS weight. Record on Figure 12.
- f. An acceptable result is 0.001 grams/ft<sup>2</sup>
- g. From the original sample, take a representative 500-ml sample.
- h. Filter the 500-ml sample using millipore equipment with a 0.45 micron millipore pad. The filtrate shall be analyzed according to section 14.2.
- i. Examine the residue collected on the millipore pad with a microscope having a power factor of at least 45. Size the particles with a calibrated filar micrometer.
- j. Determine the number of particles in each range listed below in (m).
- k. Divide the number of particles in each range by the number of square feet represented by the sample.
- l. Record the results calculated for each of the particle ranges on Figure 16.
- m. An acceptable sample shall meet the following requirements:

<b>PARTICLE SIZE</b>	<b>MAXIMUM PARTICLE POPULATION PER SQUARE FOOT</b>
0 - 99 microns	No Limit ★
100 - 250 microns	93
251 - 300 microns	3
301 microns or more	0

★ No discoloration of filter pad is allowed.

#### 14.2

#### NONVOLATILE RESIDUE ANALYSIS PROCEDURE

The following procedure shall be used to determine NVR.

- a. Transfer the filtrate sample collected in section 14.1 to a clean, degreased 800-ml beaker.



- b. Evaporate the sample to a volume of  $15 \pm 5$  ml in a steam bath or on a hot plate maintained at a maximum temperature of 220° F.
- c. Transfer the sample to a 30-ml weighing bottle. The weighing bottle shall have a constant tare weight within 0.3 milligrams (mg) and shall be weighed to the nearest 0.1 mg on a balance calibrated on a yearly basis. The tare weight shall be recorded.
- d. Place the weighing bottle in a constant temperature oven that has been normalized between 221° and 230° F. The weighing bottle shall remain in the oven for 1.5 hours or until the sample has completely dried.
- e. Remove the weighing bottle from the oven, and cool in a desiccator.
- f. When cool, weigh the weighing bottle to the nearest 0.1 mg on a balance calibrated yearly. Record the results.
- g. Place the weighing bottle back in the normalized oven. After 1/2 hour, remove the weighing bottle and cool in the desiccator. When cool, weigh the weighing bottle to the nearest 0.1 mg on a balance calibrated on a yearly basis. Repeat (g) until two consecutive results are equal within 0.3 mg. Record the results.
- h. Subtract the tare weight of the weighing bottle from the results obtained in (g). Record the results.
- i. Subtract the base solvent NVR content (refer to paragraph 10.3.9 or 13.2.8) from the results obtained in (h). Record the results.
- j. Divide the result obtained in (i) by the number of square feet represented by the sample. Record the obtained NVR on Figure 16.
- k. An acceptable sample shall have an NVR result that does not exceed 1 mg per square foot.

**15.0 QUALITY ASSURANCE PROVISIONS**

**15.1 GENERAL**

The requirements of this section shall be performed in conjunction with Quality Assurance requirements specified in the contract schedule.

**15.2 CONFIGURATION CONTROL**

The Subcontractor shall establish a system for maintaining configuration control of each trailer/MSU during the work process. Written approval from the Subcontract Administrator on an RFI is required for any trailer/MSU modification (if not otherwise permitted in this standard) or any substitution of items that are not exact replacements of the original item. Drawings depicting each trailer's/MSU's configuration will be provided to the Subcontractor. Approved configuration changes shall be documented by the Subcontractor in the form of redline drawings and incorporated as a portion of the data package.

**15.3 HYDROSTATIC TEST FACILITY**

The Hydrostatic Test Facility shall be approved by the Department of Transportation with a current certification. The Subcontractor shall be responsible for coordination with the DOT to have a representative inspect the test apparatus and witness the test procedure. Approval by the DOT shall not exceed an interval of 5 calendar years.

**15.4 CHEMICALS AND MATERIALS**

All chemicals and materials shall be certified and maintained to applicable referenced government specifications. Certifications shall be maintained on file and shall be supplied to the Subcontract Administrator as part of the data package. On items not covered by applicable referenced government specifications, the manufacturer specification shall govern.

**15.5 COMPONENT CONTROL**

The Subcontractor shall implement a system of component control and status (tagging) during processing through the plant (i.e., hold for cleaning, repair, replace, scrap, etc.).

15.6 FACILITY CONTROL

The Subcontractor shall provide and maintain a current operational manual of sufficient procedural detail to depict as a minimum the following:

- a. Process methods to be used to ensure compliance with this standard.
- b. Controls to be established over calibrated equipment, test gages, fluids, solvents, acids/caustic concentration levels, room environment checks (i.e., airborne particulate, room temperature, pressurization, humidity, etc.).
- c. Controls to be established over Contractor furnished equipment (CFE).

These procedures shall be to the satisfaction of the Subcontract Administrator or their designated representative.

15.7 SUBMITTALS

The Subcontractor shall submit the following items to the BOC annually or whenever changes occur:

15.7.1 DOT HYDROSTAT/INSPECTION CERTIFICATION

The subcontractor shall submit their DOT certification including a list of certified personnel.

15.7.2 CHEMICAL SAMPLING PLAN

The Subcontractor shall submit a sampling plan to ensure the chemicals meet the requirements specified herein.

15.7.3 CLEANING PROCEDURE

The Subcontractor shall submit a cleaning procedure for approval if it is different from the methods listed in this standard.

**15.7.4 WELDER QUALIFICATIONS**

The Subcontractor shall submit welder qualifications per AWS D1.1 and AWS D1.2.

**15.7.5 TUBE FABRICATION PROCEDURE**

The Subcontractor shall submit a tubing fabrication procedure which is compliant with KSC-SPEC-Z-0008.

**15.7.6 LUBRICANT CERTIFICATION**

The Subcontractor shall submit lubricant certifications to ensure compliance with the requirements specified herein.

**15.7.7 LIST OF "SUBSTITUTIONS"**

Any substitution of "equivalent" items shall require the prior approval of the Subcontract Administrator or their representative.

**16.0 PREPARATION FOR DELIVERY**

**16.1 PREPARATIONS**

The Subcontractor shall take whatever precautions are necessary to ensure the trailer/MSU arrives at KSC in the same condition the trailer/MSU was in, after the final inspection, prior to delivery. Operational and visual checks shall be made by the Subcontractor to ensure the trailer/MSU can be transported without damage to the trailer/MSU, safely, and in accordance with federal, state, and local regulations. Normal travel wear will be acceptable.

**16.1.1 LICENSE TAG**

The government license tag supplied with the trailer shall be reinstalled in the location license was prior to removal.

**16.1.2 LUBRICATION**

Verify the fifth wheel plate, landing gear and axle bearings are greased.

**16.1.3 LEAK CHECK**

The airbrake line fitting connections shall be leak checked with soap solution while the line is under full tractor supplied air pressure. No leaks are permitted.

**16.1.4 TRAILER/MSU PRESSURIZATION**

Trailer/MSU shall be pressurized to 25 +0, -10 psig with GN<sub>2</sub> prior to transport to KSC. Keeping trailer/MSU pressure below 40 psia will allow transport of the trailer/MSU to KSC without it being labeled and placarded.

**16.2 FINAL INSPECTION**

The Subcontractor shall make a final inspection of the trailer/MSU and all documentation developed related to the trailer/MSU to ensure that all conditions specified in this standard have been complied with prior to transporting the trailer/MSU to KSC. This inspection shall be documented on Figure 19.

**17.0 EXCEPTIONS AND DEVIATIONS**

Request for exceptions and/or deviations from the requirements of this standard shall be submitted to the Contractor for review on an RFI (Figure 18) or DCN (Figure 23). When filling out the document the Subcontractor must list the specific section of the standard from which deviation/exception is requested. The form is valid only if all Contractor signatures are obtained.

**18.0 APPENDIX A: COATING SYSTEMS**

**A1.0 PREPARATION AND APPLICATION OF COATING SYSTEMS**

Appendix A of this standard outlines four methods of refurbishment. The Contractor will select the appropriate methods according to the extent of corrosion and will include this direction in the SOW. One of the methods will be employed for each individual piece of the trailer/MSU (e.g., cylinder, chassis, or bulkheads).

**A1.1 DOCUMENTATION**

The application of coatings shall be documented on Figures 9 and 25-29.

**A2.0 EQUIPMENT**

**A2.1 GENERAL**

All tools and equipment to be used on this project shall be completely operable, maintained in good working order, and utilized in a manner recommended by the manufacturer. Faulty tools and equipment shall not be used. Tools and equipment shall comply with applicable OSHA Standards.

**A2.2 COMPRESSED AIR**

The compressed air system shall be capable of delivering a continuous nozzle pressure to achieve the required surface cleanliness and profile (typically 90 psi minimum) to each blast nozzle in use throughout the blasting operation. The required air capacity will depend upon the configuration of the abrasive system used. The air system should comply with the instructions and recommendations of the manufacturer of the abrasive blasting system. The compressed air system shall be equipped with oil and moisture separators to ensure only clean, dry air is provided to the service outlet. Compressed breathing air shall meet the requirements of OSHA, 29 CFR 1910.134 (d).

**A2.3 ABRASIVE BLASTING SYSTEM**

The abrasive blasting system shall be an Occupational Safety and Health Act (OSHA) approved configuration consisting of, but not limited to, a remote controlled welded pressure pot conforming to ASME standards, the required length of blast hose, a tungsten carbide venturi nozzle, a

respiratory air line filter, and a blast hood approved by the Mine Safety and Health Administration/National Institute of Occupational Safety and Health with the required length of air hose. The blasting system shall be designed to produce the specified cleanliness and profile when coupled with the available air supply.

#### A2.4 COATING APPLICATION SYSTEM

The coating application equipment shall be an airless spray system, conventional spray system, or other approved spray equipment in accordance with the coating manufacturers recommendations. Brush application may be used for minor touch-up.

#### A2.5 NEEDLE SCALER

The needle scaler shall be of the type and size required to perform minor touch-up operations. The needles shall be replaced when they become dull or rounded.

#### A3.0 MATERIAL REQUIREMENTS

##### A3.1 COATINGS

To ensure compatibility, coatings or components of coatings shall be of same manufacturer. In addition, all thinners and cleaners shall also be a product of the coating manufacturer.

##### A3.1.1 SOURCE OF SUPPLY

Sources for coatings are listed in Table 3 (Appendix G). The table lists the approved product numbers and manufacturers for the types of coatings used in this standard. All coatings shall be selected from table 3.

##### A3.2 COLOR REQUIREMENTS

The trailer/MSU finish coat shall be white color number 17875 per FED-STD-595. Topcoat shall conform in gloss, hue, and chroma to FED-STD-595. The Subcontractor shall verify conformance to color requirements, by use of 3 by 5 inch chips as specified in FED-STD-595, prior to colored topcoat application. When Ameron Amercoat 450 HS finish coat is used, the color shall be Ameron standard white, designated as WH-1.

**NOTE**

*Experience has shown that manufacturers have had difficulty in producing topcoating material matching the colors specified in FED-STD-595, particularly white color #17875. Special care must be exercised to ensure proper compliance with the hue, chroma, and gloss requirements of FED-STD-595.*

**A3.2.1 WHEELS**

The finish coat for the wheels shall be black (Color #17038).

**A3.2.2 QUICK DISCONNECTS**

The service air hose quick disconnect shall be green (color #14110). The emergency air hose quick disconnect shall be red (color #11105).

**A3.2.3 ALIGNMENT MARK**

A tractor/trailer engagement alignment mark shall be painted on the front of the trailer. The mark shall be black (color #17038), 2 inches wide and extend 4 inches from the bottom of the fifth wheel plate and located the same distance from the side of the trailer as the kingpin.

**A3.3 ABRASIVE BLASTING AGGREGATE**

The material used for abrasive blasting shall conform to SSPC-AB 1, Type 1, Class B, Grade 2.

**A3.4 INORGANIC ZINC PRIMER**

The manufacturer shall add a colored tint to the inorganic zinc primer, to provide color contrast between the newly applied inorganic zinc primer and the prepared metal surface.

**A4.0 PROCEDURES**

These procedures are applicable to all methods of refurbishment.

**A4.1 APPLICATOR QUALIFICATIONS**

To ensure the highest quality of workmanship, only journeyman applicators having extensive prior experience in abrasive blasting and the



application of high-performance protective coatings shall be assigned to perform the work described herein. The Subcontractor shall be responsible for providing all painting personnel formal training on the proper mixing and application of the coatings specified, particularly inorganic zinc coatings. Topics covered in the orientation shall include requirements of this standard, material application characteristics, and inspection criteria. Only personnel receiving training may mix or apply the coatings. The training shall be witnessed, verified, and documented by the Subcontractor's Quality Control Inspector. The Subcontractor shall maintain a record of personnel training.

#### A4.2 PREPARATION OF SURFACES

All surfaces to be coated shall be clean, dry and free from oil, grease, dirt, dust, corrosion, peeling paint, weld spatter, and any other surface contaminants/defects. All surfaces that will become inaccessible after fabrication, reassembly, or installation shall be prepared and coated while accessible. Carbon steel faying surfaces that are part of friction-type joints shall be abrasive blasted and coated with 4-6 mils of inorganic zinc (only) prior to installation. Surface preparation and coating operations shall be sequenced so that freshly applied coatings will not be contaminated by dust or foreign matter. The specified protective coating shall be applied immediately following inspection and approval of the surface preparation.

##### A4.2.1 PROTECTION OF EQUIPMENT AND ADJACENT SURFACES

All equipment and adjacent surfaces not to be coated shall be protected from surface preparation operations. All copper and stainless steel tubing, tires, brake shoes, trailer manufacturer's identification tags, airbrake connection openings, light lenses, and reflector lenses shall be protected from damage and coverage from coating applications. Cylinder ends shall be blanked off during blasting operations. Working mechanisms shall be protected against intrusion of abrasive. Cylinder threads shall be protected from damage.

##### A4.2.2 DEGREASING

All surfaces shall be degreased, as required, prior to subsequent surface preparation procedures or the application of protective coatings, or both. Degreasing shall be by solvent cleaning, detergent washing, or steam cleaning per SSPC-SP-1.

**A4.2.3 MECHANICAL CLEANING**

Mechanical cleaning of carbon steel and aluminum shall be used only as specified in the SOW for the trailer/MSU. No impact tools shall be used on the cylinders and cylinder threads.

For carbon steel, power tool cleaning shall be per SSPC-SP 11. Hand tool cleaning shall be per SSPC-SP 2. Carbon steel shall be mechanically cleaned using needle scalers and/or 3M Clean & Strip Wheels (or equal). All corrosion and foreign matter shall be removed, leaving the surface cleanliness equivalent to near white metal (SSPC-SP 10).

Aluminum shall be mechanically cleaned using power sanders or 3M Clean-N-Strip wheels. All corrosion, loose paint, and foreign matter shall be removed and the cleaned surface slightly roughened.

**A4.2.4 EDGE FEATHERING**

When performing spot repairs, edges of adjacent coating shall be feathered so that the recoated surface will have a smooth appearance. To ensure a smooth appearance of the topcoat after spot repairs, glazing putty similar or equal to 3M brand Aceyl Blue may be used for the filling of minor low areas or grinding/sanding line imperfections on primed and sanded areas. The glazing putty shall be sanded and feathered to match adjacent surfaces.

**A4.2.5 WATERBLASTING**

Waterblasting shall be used to clean surfaces prior to mechanical cleaning, abrasive blasting, or the application of coatings. It shall be accomplished using standard industrial pressure cleaners with a pressure versus volume output balance that will ensure thorough and productive cleaning. The system shall be capable of an output pressure of 2500-4500 psi. The cleaned surface shall be completely free of all loose coatings, chlorides, dirt, dust, mildew, grinding/welding/cutting debris, and any other surface contaminants. The surface shall be clean and dry prior to sandblasting operations and/or the application of coatings. Care shall be exercised in the use of high pressure cleaning equipment to prevent destruction or removal of protective coating, decals, and caulking, or the penetration of water into moisture sealed areas. In the event of any such damage, steps shall be taken to restore the damaged areas to their original condition.

**A4.2.6 DUST REMOVAL**

Before coatings are applied all dust shall be removed from the cleaned surfaces by vacuuming.

**A4.3 STORAGE OF COATING MATERIALS**

Coatings shall be purchased in containers no larger than 5 gallons. Coating containers shall be received unbroken and shall show: product identification, shelf life, batch numbers, color, date of manufacture, manufacturer's name and address. Manufacturer's instructions for storage limitations shall be followed. Coating materials shall be stored in their original containers. Coatings, thinners and cleaners shall be stored in tightly closed containers in a covered, well-ventilated area where they will not be exposed to sparks, flame, direct sunlight, high heat or rainfall. Tarps and plastic coverings shall not be used to cover coating materials.

**A4.4 MIXING INSTRUCTIONS**

Coating materials shall be thoroughly mixed prior to application with a mechanical mixing instrument that will not induce air into the coating, such as Jiffy Mixer, manufactured by Jiffy Mixer Co., Inc., San Francisco, Ca., or approved equal. The mixer shall be powered by an air motor or an explosion proof electric motor. Rapid agitation shall be avoided. Continuous slow agitation shall be provided during application of all coatings to maintain uniform suspension of solids. The mixed coating material shall be strained through a 30 to 60 mesh screen prior to application. Thinning shall be for viscosity control only. The manufacturer's recommended thinner and amount shall be used.

**A4.5 ENVIRONMENTAL CONDITIONS**

No coatings shall be applied when the temperature or humidity is outside limits recommended by the coating manufacturer. To prevent moisture condensation during coating application or blasting operations, surface temperature must be at least 5 degrees Fahrenheit above the dewpoint and not falling.

**A4.6 APPLICATION OF COATINGS**

All prepared surfaces shall be coated immediately after completion of inspection and approval of surface preparation and before corrosion or recontamination occurs. Any surface that shows corrosion or con-

tamination, shall be re-prepared per the applicable surface preparation section.

Coatings shall be applied with airless or conventional spray equipment, or both. Airless may be used for uniform, large surface areas. Conventional should be used for small areas and those of intricate configuration. Application with brushes will be permitted for minor touchup and stripe coating. Spray equipment shall be adjusted to produce an even, wet coat with minimum overspray. The conventional pressure pot, when used, shall be kept at approximately the same level or above the spray gun for proper material delivery. Coatings shall be applied in even, parallel passes, overlapping 50 percent. Special attention shall be paid to welds, cutouts, sharp edges, rivets, crevices, and bolts to ensure complete coverage and proper thickness. These areas shall be stripe coated using a brush prior to application of coating with a spray gun.

All coatings shall be thoroughly worked into all joints, crevices and open spaces. All newly coated surfaces shall be protected from damage. All equipment and adjacent surfaces not to be coated shall be protected from overspray and splattered coatings.

The application and handling characteristics of all coatings will vary. To obtain optimum performance, adequate instructions from the manufacturer are essential and must be closely followed, in conjunction with the requirements defined herein. Manufacturer's instructions for thinning, mixing, handling, curing, cleaning and applying his product shall be a part of this standard. The Subcontractor shall comply with the manufacturer's instructions and recommendations to prevent problems such as mudcracking, bubbling, etc.

#### A4.6.1 STRIPE COATING

Special attention shall be paid to welds, cutouts, sharp edges, rivets, crevices, and bolts to ensure complete coverage and proper thickness. These areas shall be stripe coated using a brush prior to application of coating with a spray gun.

#### A4.7 COATING FINISH

Each coat of material applied shall be free of runs, drips, ridges, waves, laps, brush marks, sags, blisters, bubbles, mudcracking; variations in color, gloss, and texture; holidays (missed areas), excessive or

insufficient film build-up, foreign contaminants, dry overspray, etc. Each coat of applied material shall be rendered clean, fully cured, and free from surface contaminants prior to the application of successive coats.

**NOTE**

*Solvent based, ethyl silicate inorganic zinc coatings require reaction with atmospheric moisture to reach adequate cure.*

**A4.8 COATING DRY FILM THICKNESS (DFT)**

Inorganic zinc coatings shall be applied to a DFT of 2.5 to 4.0 mils when they are to be finish coated and to a DFT of 4.0 to 6.0 mils when they will be left uncoated. Mudcracking is not acceptable at any DFT. The proper DFT for the inorganic zinc coating shall be obtained in a single application, which may consist of multiple passes, while coating is still wet. All other coatings shall be applied to the DFT recommended by the manufacturer except when using a "high build" corrosion inhibitive epoxy primer intermediate coat. A high build corrosion inhibitive epoxy primer intermediate coat shall be applied to a DFT of 2 to 3 mils. The film thickness of the topcoats shall be sufficient to ensure uniform coverage and color.

**A4.9 COATING DRYING AND CURING**

The coating manufacturer's recommended drying and curing time for handling, recoating and topcoating shall be followed (the coating shall be completely cured, in accordance with the manufacturer's instructions, before handling cylinders). Inorganic zinc coatings shall be checked for adequate cure by ASTM D 4752 "Standard Test Method for Measuring MEK Resistance of Ethyl Silicate Inorganic Zinc-Rich Primer by Solvent Rub" prior to applying topcoats.

**A5.0 COMPLETE REFURBISHMENT OF CARBON STEEL SURFACES**

The following is applicable to any carbon steel surface that requires complete refurbishment due to failure of the existing coating system resulting in large scale delamination or general corrosion. General corrosion is defined as corrosion evenly dispersed throughout a given area.

**A5.1 SURFACE PREPARATION**

The Subcontractor shall verify equipment protection requirements have been adhered to prior to surface preparation. Special protection shall be given to thread areas on cylinders, mounting bolts, and tie rods as damaged threads may cause expensive repair or replacement. After cylinder external thread cleaning and application of primer, special care shall be taken to prevent coating build-up during trailer/MSU reassembly. Existing sealant shall be removed prior to abrasive blast cleaning. All weld slag, weld spatter and foreign matter shall be removed from welds prior to abrasive blasting.

**A5.1.1 ABRASIVE BLAST CLEANING**

Dry abrasive blasting shall be used. Blast media shall meet the requirements of Section A3.3. Surfaces shall be dry prior to abrasive blasting. Blasting of threaded surfaces which support commodity system functions is strictly prohibited (i.e. cylinder internal threads, fitting threads, non-mounting component threads etc.). Threaded surfaces which support commodity system functions may be cleaned using wire brushes which are made of the same material as the surface which they will be used on.

**A5.1.2 EXCESSIVE RUST AND SCALE**

Prior to abrasive blasting, excessive rust and scale shall be removed by chipping or power tool cleaning. No impact tools shall be used on the cylinders and cylinder threads.

**A5.2 BLAST CLEANED SURFACE FINISH**

Carbon steel shall be abrasive blasted to near-white metal (per SSPC-SP-10 & SSPC-VIS 1). The anchor profile of the blasted surface shall be 1.5 to 3.0 mils as measured by replica tape. All rust shall be completely removed from pits and depressions.

**A5.3 PRIMER**

All surfaces abrasive blast cleaned under this specification shall be coated with an inorganic zinc primer. All paint coatings must be applied in a building per the requirements of paragraph 3.2. Steps shall be taken to prevent paint coating build-up between lug, brake drum, wheel

interfaces and friction joints. Only light zinc primer application is required in these areas.

**A5.3.1 WATER WASH AND SCRUB**

The applied inorganic zinc coating shall be scrubbed with a stiff fiber bristle brush and rinsed with fresh potable water prior to intermediate coat application. Following this wash, the inorganic zinc coating shall be checked for complete cure in accordance with Section A4.9. The intermediate coat shall not be applied unless the zinc coating has been completely cured per the manufacturer's instructions.

**A5.4 INTERMEDIATE COAT**

A polyamide cured, corrosion inhibitive epoxy intermediate coat shall be applied after the inorganic zinc coating has cured per the manufacturer's instructions.

**A5.5 SEALING**

Sealant shall be applied after the epoxy intermediate coat has fully cured per the manufacturer's instructions. Caulking around cylinder bulkhead nuts, threads and the bulkhead shall be applied at locations indicated in Figure 24.

**A5.6 FINISH COAT**

An aliphatic polyurethane finish coat shall be applied following sealant application.

**A6.0 COMPLETE REFURBISHMENT OF ALUMINUM SURFACES**

The following is applicable to aluminum surfaces that require complete refurbishment due to failure of the existing coating system resulting in large scale delamination or general corrosion. General corrosion is defined as corrosion evenly dispersed throughout a given area.

**A6.1 SURFACE PREPARATION**

The Subcontractor shall verify equipment protection requirements have been adhered to prior to surface preparation. Paint removal from aluminum shall be by dry abrasive blasting, chemical stripping, or hand

sanding. Existing sealant shall be removed prior to abrasive blast cleaning.

### **CAUTION**

*Some aluminum configurations are susceptible to distortion when they are abrasive blasted. Special care shall be taken to ensure against any metal distortion by reducing blast nozzle pressure and increasing the working distance from nozzle to surface. In some cases, such as in the preparation of light gage sheet, these precautions may not be sufficient to prevent distortion, and an alternate procedure such as sanding or mechanical cleaning, must be used to remove corrosion or roughen the surface.*

#### **A6.1.1 ABRASIVE BLAST CLEANING**

Dry abrasive blasting shall be used. Aluminum shall be abrasive blasted with an abrasive that is compatible with the base metal and capable of removing corrosion and old coatings or roughen new surfaces. The blasted surface shall be free of all corrosion and foreign matter and have a uniform, slightly roughened appearance. Surfaces shall be dry prior to abrasive blasting. An alternate method of abrasive blasting may utilize abrasive grain (glass beads) conforming to MIL-G-9954A. If any aluminum oxide is present after initial abrasive blasting, glass bead blasting is acceptable in lieu of solvent stripping or hand sanding.

### **WARNING**

*Perform stripping operations in an area with adequate ventilation or use OSHA approved respiratory equipment. (Refer to MIL-D-6998 for the specific hazards associated with the use of Dichloromethane and Methylethylketone). Avoid breathing and skin contact. In case of contact, wash affected area with large amounts of water and obtain medical assistance.*

### **CAUTION**

*Prevent contact of stripping agent with plastic materials, rubber or lubricated parts when reuse is a requirement of this standard.*

*For large parts or difficult to reach places, apply lacquer thinner, Methylethylketone or Dichloromethane by soft bristle brush or clean cloth. Allow solvent to remain on the surface until paint has softened or*



*lifted. Remove the excess solvent and paint film by wiping with a damp cloth. Repeat the solvent soak process until all paint is removed. Final wipe the cleaned surface with a damp lint free wiper.*

A6.1.2 STRIPPING

Stripping of accessible and confined areas may be accomplished using lacquer thinner (TT-T-266), Methylethylketone (TT-M-261) or Dichloromethane (MIL-D-6998).

A6.1.3 SANDING

Hand sanding may be used on small areas using 220 grit aluminum oxide abrasive paper.

A6.1.4 CORROSION REMOVAL COMPOUND

**WARNING**

*Rubber gloves, aprons, eye protection, and nonporous shoes shall be worn when handling hazardous chemicals to prevent skin contact. In case of contact, flush with water and obtain medical assistance.*

**CAUTION**

*MIL-C-38334 Type I material shall not be used after one year from the date of manufacture. Type II shall be used within 90 days of solution preparation.*

**CAUTION**

*Do not use steel wool on aluminum surfaces as steel particles may enhance the corrosion process.*

**NOTE**

*In the application of corrosion removal compound, mask all parts/assemblies that can trap or be damaged by MIL-C-38334 material with masking tape, polyethylene film or barrier paper. Apply the MIL-C-38334 solution (Type I material will be diluted with equal amounts of water) by brush, spray or sponge. Agitate the solution over the corroded surface with a stiff bristle brush, allow the solution to remain in contact for at least 10 minutes, and then rinse the surface with tap water or a*

*damp, lint free wiper. Additional corrosion removal solution shall be added as above until all corrosion has been removed. Final wipe the clean surface area with a damp lint free wiper.*

**A6.3 PRIMER**

Aluminum surfaces shall be primed with polyamide cured, corrosion inhibitive epoxy.

**A6.4 SEALING**

Sealant shall be applied after the primer has cured per the manufacturer's instructions.

**A6.5 FINISH COAT**

An aliphatic polyurethane finish coat shall be applied to primed and sealed surfaces.

**A7.0 TOUCHUP REFURBISHMENT OF SURFACES**

The following is applicable to carbon steel or aluminum surfaces with damaged coatings exposing the substrate, or surfaces with local corrosion. Local corrosion is defined as corrosion concentrated in a given area.

**A7.1 SURFACE PREPARATION**

Damaged surfaces (primer or local corrosion) shall be prepared by power tool cleaning per SSPC-SP 11 (for steel). Aluminum shall be prepared, by power or hand tool cleaning, until the surface is free of all contaminants and has a slightly roughened appearance. Small local areas of pitted corrosion on the cylinders shall be spot abrasive blasted per SSPC-SP-10. Edges shall be feathered.

**A7.2 PRIMER/INTERMEDIATE COAT APPLICATION**

Cleaned areas shall be primed with a polyamide cured, corrosion inhibitive epoxy.

**A7.3 SEALING**

Any bleed through of rust in old sealant shall necessitate a new application of sealant. The old sealant shall be completely removed and all corrosion eliminated. Sealant shall be applied after epoxy primer has cured.

**A7.4 FINISH COAT**

An aliphatic polyurethane finish coat shall be applied after the epoxy primer has cured.

**A8.0 TOUCHUP OF FINISH COAT**

Surfaces on which the colored finish coat has been damaged, oxidized, or discolored but the primer and intermediate coat are intact and have no evidence of corrosion or delamination shall be prepared and recoated in accordance with the following paragraphs.

**A8.1 SURFACE PREPARATION**

Damaged areas shall be prepared by handsanding. If the primer coat is damaged during preparation, the damaged area shall be refurbished in accordance with section A7.0.

**A8.2 FINISH COAT TOUCHUP**

An aliphatic polyurethane finish coat shall be applied. The material and color shall be the same as the colored topcoat. Touchup coating shall be uniform in color with the previous colored finish coat.

**A9.0 REFURBISHMENT OF VINYL FINISH COAT WITH APPLICATION OF POLYURETHANE FINISH COAT**

Surfaces on which the existing colored finish coat has been damaged, oxidized, or discolored and the primer has been damaged in areas and the substrate has evidence of corrosion shall be prepared and recoated in accordance with the following paragraphs.

**A9.1 SURFACE PREPARATION**

Pressure clean entire surface per SSPC-SP1 using minimum 3,000 psi water blaster to remove oxidized paint (chalk), mildew/mold, and dirt.

Damaged areas with failed coating and/or corrosion shall be mechanically cleaned per SSPC-SP11 (for steel). Aluminum shall be prepared by power or hand tool cleaning, until the surface is free of all contaminants and has a slightly roughened appearance. No impact tools shall be used on cylinders. Small local areas of pitted corrosion on the cylinders shall be spot abrasive blasted per SSPC-SP-10. Edges shall be feathered. The Subcontractor shall ensure all dust is removed by vacuuming prior to recoating.

**A9.2 PRIMER**

Spot prime mechanically cleaned areas with Amercoat 182 HS at 3 mils DFT.

**A9.3 SANDING**

The existing undamaged finish coat shall be very lightly sanded to remove any embedded particles and surface debris. 220 grit Aluminum Oxide abrasive paper shall be used.

**A9.5 INTERMEDIATE COAT**

Apply one coat of Amercoat 182 HS at 3 mils DFT to the entire surface.

**A9.6 FINISH COAT**

Apply one coat of Amercoat 450 HS, standard white WH-1, at 2 - 3 mils DFT to the entire surface.

**A10.0 SPOT REPAIR WITH COMPLETE FINISH COAT**

The following is applicable to carbon steel or aluminum surfaces with damaged coatings exposing the substrate, or surfaces with local corrosion. This section differs from section A9.0 in that the whole assembly shall be re-coated with the existing finishcoat after repair of the damaged area.

**A10.1 SURFACE PREPARATION**

Damaged surfaces (coating or local corrosion) shall be prepared by power tool cleaning per SSPC-SP 11 (for steel). Aluminum shall be prepared, by power or hand tool cleaning, until the surface is free of all contaminants and has a slightly roughened appearance. Small local

areas of pitted corrosion on the cylinders shall be spot abrasive blasted per SSPC-SP-10. Edges shall be feathered.

A10.2 PRIMER

Cleaned areas shall be primed with a polyamide cured, corrosion inhibitive epoxy.

A10.3 SEALING

Any bleed through of rust in old sealant shall necessitate a new application of sealant. The old sealant shall be completely removed and all corrosion eliminated. Sealant shall be applied after priming.

A10.4 FINISH COAT

Finish coat shall be applied to the whole assembly (e.g. cylinder, cabinet, etc.).

A11.0 PROCEDURE FOR PAINTING CYLINDER THREADS

**WARNING**

*Abrasive blasting shall not be utilized as a surface preparation method on cylinder threads! Cylinder threads must be protected from exposure to the abrasive blasting media during surface preparation of adjacent areas. Impact tools shall not be used on cylinders and cylinder threads.*

A11.1 SURFACE PREPARATION

Prepare cylinder threads by wire brushing in accordance with SSPC-SP 3, Power Tool Cleaning. Extreme caution shall be exercised to prevent erosion of the cylinder threads and to prevent damage of adjacent coatings.

A11.2 EPOXY PRIMER

Apply one coat of a polyamide cured, corrosion inhibitive epoxy primer at 2 - 3 mils DFT to the entire threaded area.

**A11.3      INSTALL BACKUP NUTS**

After the epoxy primer has cured per the manufacturer's instructions, install backup nuts.

**A11.4      PROTECTION OF ADJACENT CYLINDER THREADS**

Protect by taping, or other appropriate method, the outside  $\frac{3}{4}$  inch of the cylinder threads.

**A11.5      FINISH COAT**

Apply one coat of an aliphatic polyurethane finish coat to the untaped threaded area at 2 - 3 mils DFT.

**A11.6      INSTALLATION OF CYLINDERS AND BULKHEAD NUTS**

After the finish coat has cured per the manufacturer's instructions, remove the tape from the ends of the cylinders, install the cylinders onto the trailer, and install the bulkhead nuts.

**A11.7      COATING CYLINDER ENDS**

Apply one coat of an aliphatic polyurethane finish coat to the ends of the cylinders at 2 - 3 mils DFT.

**A12.0      QUALITY ASSURANCE PROVISIONS**

**A12.1      RESPONSIBILITY FOR INSPECTION**

Inspection is required for all surface preparation and coating applications to ensure the requirements of this standard are fulfilled. The Subcontractor is responsible for meeting the surface preparation and coating application requirements of this standard.

The Government and/or Contractor reserves the right to perform any or all of the inspections set forth in this standard. The Contractor may, at their discretion, use the services of a NACE certificated inspector to observe and evaluate the Subcontractor's surface preparation and coating application techniques.

The Subcontractor's inspector shall record and document all inspections on the applicable inspection forms (refer to Figures 25 - 29). The daily inspection reports documenting compliance with the Quality Assurance Provisions defined herein shall be prepared and signed daily and submitted to the Subcontract Administrator as part of the data package for that specific trailer/MSU. The report shall be made available to Contractor QA upon request. The Subcontractor's inspector shall be responsible for conducting and recording all hold-point inspections required by paragraph A12.2. When a nonconformance report is required, it shall be signed and submitted to the Subcontract Administrator within 1 working day from the time it was written. After determining that all nonconformances have been corrected and/or the coating work is in compliance with the requirements of this document, a conformance verification report shall be completed for the specific trailer/MSU. Forms can be obtained from the Subcontract Administrator.

**A12.2 INSPECTION HOLD POINTS**

- a. Verification of ambient weather conditions.
- b. Prior to beginning of surface preparation work, to include the operation of equipment.
- c. After surface preparation work and before the beginning of the application work, to include the mixing of products.
- d. Before and after the application of each coat of material.
- e. After completion of coating and prior to final acceptance.

**A12.3 INSPECTION PRIOR TO SURFACE PREPARATION AND COATING APPLICATION**

The following conditions shall be inspected by the Subcontractor's inspector prior to commencement of surface preparation and coating application operations. The inspection results shall be recorded in the log book.

**A12.3.1 SURFACE CONDITION**

The surface condition shall be visually inspected for compliance with section A4.2 when prepared according to sections A5.0 through A10.0.

**A12.3.2 PROTECTION OF ADJACENT SURFACES**

Surfaces shall be visually inspected for adequate protection of adjacent surfaces in accordance with section A4.2.

**A12.3.3 AMBIENT WEATHER CONDITIONS**

The ambient weather conditions at the actual location of the work shall be determined before and during surface preparation and coating application operations to ensure they are correct for the work being conducted. The air temperature, relative humidity, and dewpoint shall be determined through the use of a psychrometer in accordance with the manufacturer's instructions. The surface temperature shall be determined by using surface temperature thermometer.

**A12.3.4 COMPRESSED AIR CLEANLINESS**

The compressed air supply shall be inspected for the use of inline moisture and oil traps. Proper functioning of the traps shall be evaluated daily by allowing the air supply (downline from the traps) to blow against a clean, white cloth for several minutes. No moisture or oil should be deposited on the cloth.

**A12.4 SURFACE PREPARATION INSPECTION**

The following inspections shall be made by the Subcontractor's inspector to ensure compliance with section A4.2. Any areas not meeting the surface preparation requirements shall be recleaned until approved. No coatings shall be applied until the surface preparation is approved. Inspection results shall be recorded in the log book.

**A12.4.1 ABRASIVE BLASTING MATERIAL**

The abrasive blasting material shall be verified for compliance with paragraph A5.1.1 for steel or paragraph A6.1.1 for aluminum.

**A12.4.2 BLAST NOZZLE AIR PRESSURE AND SIZE**

The air pressure at the blast nozzle shall be determined through the use of a hypodermic needle air pressure gage. The needle of the gage should be inserted as close to the nozzle as possible and in the direction of the nozzle. Pressure readings should be taken with the blasting system in complete operation. The nozzle pressure shall conform to



paragraph A2.2. The nozzle shall be checked initially and then at a frequency determined by the Subcontractor's inspector with a blast nozzle orifice gage to insure the compressor CFM correlates with the nozzle size.

**A12.4.3 DEGREE OF SURFACE CLEANLINESS**

The surface cleanliness shall be inspected after the completion of surface preparation procedures and prior to primer application to determine compliance with the applicable requirements of section A4.2. The degree of cleanliness of abrasive-blasted carbon steel shall be verified through the use of visual standards in accordance with paragraph A5.2. The surface preparation cleanliness requirements defined in section A4.2 shall be applicable to 100 percent of the subject area, including places that are difficult to reach.

**A12.4.4 SURFACE PROFILE OR ROUGHNESS**

The anchor profile of a sandblasted carbon steel surface shall be determined by using a replica tape. The profile shall be in accordance with paragraph A5.2. Replica tape shall be submitted as part of the data package.

**A12.5 COATING APPLICATION INSPECTION**

The following inspections shall be made by the Subcontractor's inspector to ensure compliance with coating application requirements defined in paragraph A4.6. Inspection results shall be recorded in the log book.

**A12.5.1 SURFACE CONDITION**

The prepared surface shall be visually inspected and the time before coating shall be monitored for compliance with paragraph A4.2 before coatings are applied.

**A12.5.2 COATING MATERIALS**

The coating materials shall be visually inspected for compliance with paragraph A3.1.

**A12.5.3 STORAGE OF COATING MATERIAL**

Coating material storage conditions shall be periodically inspected for compliance with paragraph A4.3.

**A12.5.4 MIXING AND APPLICATION OF COATINGS**

The mixing and application of all coatings shall be visually inspected to ensure compliance with paragraphs A4.4 and A4.6.

**A12.5.5 COATING FINISH AND DFT**

The finish and DFT of each applied coating shall be inspected for compliance with paragraphs A4.7 and A4.8 prior to the application of successive coats. The DFT measurement on carbon steel shall be taken using a magnetic gage in accordance with SSPC-PA-2. DFT measurement on aluminum shall be taken with an Eddy Current thickness gage.

**19.0 APPENDIX B: HYDROSTATIC TESTING**

**B1.0 CYLINDER HYDROSTATIC TEST**

Cylinders shall be hydrostatically tested in accordance with 49 CFR 173.34 (e) and CGA C-1.

**B1.1 HYDROSTATIC TEST BASIC REQUIREMENTS**

The Subcontractor shall document hydrostatic test results on Figure 15.

**B1.2 METHOD OF TEST**

The method of hydrostatic test shall be the water jacket leveling burette method (refer to Figure 3). This method of testing cylinders consists of enclosing the cylinder in a water jacket and measuring the volume of water forced from the jacket when applicable test pressure is applied to the interior of the cylinder, then measuring the volume of water remaining displaced when pressure is released. These volumes represent the total and permanent expansions respectively of the cylinder.

**B1.3 TEST PRESSURE**

Each cylinder shall be evaluated by hydrostatic test at five-thirds trailer/MSU service pressure. Test pressures are shown in Table 1.

**B1.4 TEST APPARATUS**

The important element of evaluating a cylinder by hydrostatic test is the ability to determine accurately the percent of permanent expansion of a cylinder. The following conditions are therefore essential:

1. The apparatus shall be so arranged that the water level in the expansion indicator will be the same during zero, the total expansion and the permanent expansion readings. This water level shall be above the highest point of water in the jacket and connecting piping. The expansion indicator shall be accurate to within 1 percent of the total expansion or 0.1 cc.
2. A deadweight testing apparatus shall be used to verify the accuracy of pressure gages. A master gage checked by a deadweight tester at frequent intervals is an acceptable substitute. DOT requires gage to be calibrated every six months.

3. The pressure gage shall agree with a deadweight testing apparatus within 1/2 of 1 percent at the test pressure. Gages shall have the zero stop pin removed or placed 1/2 inch below zero and a true zero marked on the dial. Gages shall permit reading to the accuracy of 1 percent.
4. A calibrated cylinder, the expansion of which at known pressure has been determined within 1 percent by a laboratory test, shall be used to check the accuracy of the apparatus and the testing operations. This also affords an additional check on the pressure gages. Each day before testing, this calibrated cylinder shall be placed in the jacket and tested in order to verify the accuracy of the test equipment. If the cylinder does not agree with the known value, the cause of the error shall be determined and corrected before proceeding with the testing.
5. The cylinder under test shall be suspended from the cover of the jacket or otherwise arranged so the cylinder is free to expand in all directions.
6. The temperatures of the water in the cylinder and in the jacket shall be within 5 degrees F of each other.
7. The test apparatus shall be constructed and used so as to eliminate the presence of air pockets. Valves, piping fittings, and all connections shall be absolutely tight and free of leaks while a cylinder is under test. The head of the jacket and all connecting pipes to the burette shall be designed with a continuous upward slope with a bleed valve at the highest point of the test head and jacket to bleed air from the head and jacket.
8. The water jacket shall be constructed so a connection can be made from the cylinder inlet port to the test apparatus and proper sealing can be provided between connector and cover and water jacket housing and cover. The water jacket shall be constructed so no strain is placed on the cylinder internal threads during handling. External cylinder neck threads may be used for structural support. The water jacket cover shall be constructed to provide a lifting eye for lifting the cylinder. The inside of the water jacket shall be kept clean from dirt or organic matter which may trap air and cause gas bubbles.

9. Adequate safety device(s) shall be provided on the water jacket to prevent damage to the test apparatus in the event of a cylinder rupture.

#### B1.5 INSTRUCTIONS FOR CARE OF CALIBRATED CYLINDER

1. Do not use a calibrated cylinder as a surge tank or capacity cylinder to slow down pumping speed when cylinders are being tested or for any purpose other than calibrating or checking the accuracy of the test apparatus.
2. Leave water and the cylinder test adapter in the cylinder between tests.
3. Do not store a calibrated cylinder outside or in any location subjected to freezing temperatures. Calibrated cylinders should be kept preferably near the test apparatus so that the temperature of the water in the cylinder and the test apparatus will remain approximately the same.

#### B1.6 INSTRUCTIONS FOR USE OF CALIBRATED CYLINDER

1. A calibrated cylinder is a cylinder which has been carefully selected and stretched permanently by means of hydraulic pressure higher than the maximum pressure for which it is used. After this is done, the cylinder has the property of expanding the same volume for each pressure unit for which it has been calibrated and return to its original volume when pressure is released. As long as the cylinder does not have a hydraulic pressure applied to it higher than its calibration or does not change its wall thickness due to rust or deterioration, it will maintain these properties. It is to be considered as an instrument for measurement rather than just a cylinder.
2. A chart shall accompany the cylinder showing the volumetric expansions in cubic centimeters at the various pressures.
3. In order to check the gage, burette and all connections to a cylinder testing apparatus, the cylinder is put into the jacket in the usual way; hydraulic pressure is applied until the volumetric expansion shown in the burette is equal to the volumetric expansion as shown on the chart for whatever pressure it is desired to test the test apparatus. Example: If it is desired to test a water

jacket, gage and equipment at 3,360 psig, and the volumetric expansion for the cylinder at that pressure is shown on the chart at 157, the pressure should be applied until 157 cubic centimeters expansion is shown on the burette. If the gage, burette and all other parts are accurate the pressure shown on the gage should be 3,360 psig at this point.

4. In using a calibrated cylinder with a testing apparatus that has not been tested before, do not make a test at a pressure near the maximum range of the calibrated cylinder, for the reason that if a gage reads low, a higher pressure than was indicated would be applied to the calibrated cylinder and would change the calibration. Check the elastic expansion as compared with the chart furnished with the calibrated cylinder; then check the pressure recorded with the expansion rather than to run the pressure up first and check the expansion last.

#### B1.7 TEST WATER

Water used for testing shall be visually clean and shall be inhibited with one-half percent by weight of sodium nitrite (Specification O-C-265) for rust prevention.

#### B2.0 HYDROSTATIC TEST PROCEDURE

A schematic of the test facility and the component designation is shown in Figure 3.

1. Install cylinder plug (D) in cylinder outlet.
2. Attach water jacket cover (O) to cylinder (A).
3. Using hoist device, lift assembly (A and O) and insert cylinder (A) into water jacket (B). Secure water jacket (B) and water jacket cover (O).
4. Open valve (L) and fill water jacket. Ensure jacket is full and the air is evacuated by opening petcock (P). When all air is evacuated, close valve (L) and petcock (P).
5. Connect water supply to cylinder connection (C). Up to this point, valves I, J, K, L, N, Q, and U are closed. Valve M is open if a recorder is being used.

6. Set zero of adjustable burette (T) at eye level.
7. Open valve (Q) and valve (I) and fill cylinder with water. Ensure cylinder is full and the air evacuated by opening valve (N). When all air is evacuated from the cylinder, close valves (N), (I), and (Q).
8. Adjust water level in burette (T) to zero by draining through valve (K).
9. Open valve (I), start pump (E), and build up cylinder pressure until pressure rises to three-fourths test pressure on gage (F). Close valve (I) and open bypass valve (Q).
10. Examine test apparatus for leakage (dropping pressure on gage (F), falling water level in burette, or beads of water at connection points).
11. If no leaks occur, open valve (I), close bypass valve (Q), and raise cylinder pressure to the test pressure. Close valve (I), open valve (Q), and stop pump (E).
12. Maintain test pressure for 30 seconds and as much longer as necessary to ensure complete cylinder expansion.
13. Read total expansion in burette (T), with water level flush with zero mark (Z). Record cylinder expansion reading on Figure 15.
14. Release pressure through valve (J) and read the permanent expansion in burette (T) with water level flush with zero mark (Z). Record reading on Figure 15.
15. Determine percent permanent expansion by dividing reading in paragraph 13 by reading in paragraph 12. Determine elastic expansion by subtracting reading in paragraph 13 from reading in paragraph 12. Record results on Figure 15.
16. If the percent permanent expansion determined exceeds 10 percent, the cylinder shall be rejected. A determination shall be made by the Subcontractor whether a second test would be permitted by DOT and, if so, the Subcontractor shall obtain concurrence of the Contractor's Designated Inspector before proceeding.

17. Disconnect test apparatus, unbolt cover from jacket, lift cylinder to top of jacket, remove cylinder plug, and drain cylinder.
18. Drain cylinder until all traces of effluent moisture cease. Plug cylinder ports and pressurize cylinder to  $10 \pm 5$  psig with  $\text{GN}_2$ . Pressurization of the cylinder is not required if cleanup process follows immediately.

**B3.0 CYLINDER STAMPING**

**B3.1 RETEST DATE**

Each cylinder passing inspection and test must be plainly marked with the date (month and year) and inspection agency symbol permanently stamped into the metal of the cylinder. For example: 1XXX83, for January 1983. Where XXX is the inspection agency's symbol. All cylinders from one trailer/MSU unit shall be stamped with same date (month and year).

**B3.2 MARKING SIZE**

The marking size shall not be less than the previous marking or greater than 1/2 inch high.

**B3.3 PREVIOUS MARKINGS**

Markings (dates) of previous tests shall not be obliterated.

**B3.4 LOCATION**

The marking shall be on the cylinder shoulder (necked down area) near the previous test markings. No markings are permitted on the cylinder body. New columns of markings on necked down area shall be used, if necessary, to satisfy this requirement.

**B3.5 LEGIBILITY**

Current markings shall not be obliterated when cylinder is recoated (painted). The Subcontractor shall take precautions (measures) to ensure adequate stamping depth. The stamping dies shall be specially ground to prevent sharp valleys or corners in markings and the hammer/die technique shall provide image depth no less than 0.030 inch.



**20.0 APPENDIX C: DEFINITIONS**

**C1.0 DEFINITIONS**

**C1.1 TRAILER**

Trailer shall be defined as the complete compressed gas semitrailer, as configured, and as received by the Subcontractor.

**C1.2 TRAILER CHASSIS**

Trailer chassis shall be defined as the trailer less the cylinders and manifold assembly.

**C1.3 CYLINDER**

Cylinder shall be defined as the compressed gas container(s).

**C1.4 MANIFOLD ASSEMBLY**

Manifold assembly shall be defined as the tubing/piping, valves, regulators, gages, and safety devices which will distribute the commodity to and from the cylinders or interconnect a series of safety devices to a common vent system.

**C1.5 COMPONENT**

Component shall be defined as the individual valve, regulator, gage, or safety device from a manifold assembly. Component parts are all the items to make an assembled component.

**C1.6 DEWPOINT**

Dewpoint specified in degree F indicates the moisture content of the GN<sub>2</sub> used in the drying operations. A dewpoint that indicates a lower moisture content than that stated in the specification shall be acceptable for meeting the requirements specified herein.

**C1.7 MOVABLE STORAGE UNIT (MSU)**

Storage unit shall be defined as the complete movable storage unit, as configured, and as received by the Subcontractor.

**C1.8 GN<sub>2</sub>**

Gaseous nitrogen used for drying, purging, or preservation shall conform, as a minimum, to Federal Specification BB-N-411C (Type I, Class I, Grade B), shall be filtered with a 25-micron absolute filter and shall have a maximum dewpoint of -65° F.

**C1.9 CFE**

Contractor Furnished Equipment.

**C1.10 BOC**

Base Operations Contractor.

**C1.11 CONFIGURATION CONTROL**

Configured parts of the trailer/MSU are the protective coating system and the fluid system. Configured parts of the trailer/MSU shall be under Configuration Control and any change must be approved by the Subcontract Administrator or their representative.

**21.0 APPENDIX D: MANIFOLD ASSEMBLY REPLACEMENT**

**D1.0 SCOPE**

Appendix D covers the requirements for the fabrication and installation of replacement manifold assemblies for compressed gas trailers receiving the new replacement chassis.

**D2.0 GENERAL REQUIREMENTS**

**D2.1 GENERAL PROJECT DESCRIPTION**

Except as noted in the statement of work, the Subcontractor shall provide all labor, materials, equipment and services for the fabrication, cleaning, testing, identification, and installation of the compressed gas trailer manifold assembly.

Components shall be installed and connected as shown on applicable drawing.

**NOTE**

*In case of a difference or conflict between drawings and specifications, the specifications shall govern. The Subcontract Administrator shall be notified immediately of any such discrepancies as they arise.*

**D2.2 GENERAL FABRICATION REQUIREMENTS**

**D2.2.1 WELDING**

Welding on the chassis and component mounting brackets shall conform to KSC-SPEC-Z-0004 Class "C" or ANSI/AWS D1.1 or D1.2. All welds shall be continuous to eliminate the possibility of moisture entrapment. Intermittent (*SKIP*) welds or welds terminating at a corner are not permitted.

**D2.2.2 BRAZING**

All brazing shall be per KSC-SPEC-Z-0005, Class A and the applicable drawing. Brazing procedures shall be validated per the requirements of KSC-SPEC-Z-0005.

Pipe fittings, with the exception of cylinder valves & burst disks, shall be silver soldered per KSC-SPEC-Z-0005, Class A.

**NOTE**

*In case of a difference or conflict between drawings and specifications, the specifications shall govern. The Subcontract Administrator shall be notified immediately of any such discrepancies as they arise.*

**D2.2.3 FASTENERS**

All fasteners and hardware used for installation shall be 300 series (except 303) stainless steel.

**D2.3 TUBING SYSTEMS REQUIREMENTS**

**D2.3.1 TUBE ASSEMBLIES**

Each tube assembly shall be fabricated to meet all minimum standards specified by KSC-SPEC-Z-0008C.

Each tubing sub-assembly shall be fabricated to the dimensional accuracy that, when assembled, no springing is required to fit in place. With exception to locations where a slope is required, all final assemblies shall be neat in appearance, all lines plumb and square or parallel to sides of trailer cabinet.

**D2.3.2 TUBE ASSEMBLY DIMENSIONAL CHECKS**

After fabrication, the inside diameter of form flared and bent tubing assemblies shall be checked to determine conformance to tube flatness and wrinkle depth as specified in KSC-SPEC-Z-0008C Para. 3.3.3 and 3.3.4 respectively.

In addition, to assure other restrictions do not exist, a spherical ball shall be passed through the flared or bent tube. The ball diameter to be used for the specific size tubing being tested shall be selected from Table 12 of KSC-SPEC-Z-0008C.

**D2.3.3 ASSEMBLY**

Joints shall be assembled using only approved compatible lubricants per KSC-SPEC-Z-0009 such as Krytox 240 AC. Coupling nut connections

shall not be over-tightened, they shall be tightened only to the torque values specified in Table 11 of KSC-SPEC-Z-0008C.

D2.3.4 TUBE SUPPORTS

All tubing shall be supported in accordance with KSC-SPEC-Z-0008C, with clamps (*Girard or equal*) where required.

D2.3.5 COMPONENT SUPPORTS

All components, valves, gages, etc., with the exception of in-line check valves, shall be independently supported (*bulkhead/panel mounted*) as required by KSC-SPEC-Z-0008C.

D2.4 CORROSION CONTROL AND PROTECTIVE COATING

D2.4.1 ALUMINUM & CARBON STEEL

Aluminum and carbon steel support brackets shall be coated per the applicable paragraphs of appendix A of this standard.

D2.5 TUBING HYDROSTATIC TESTING REQUIREMENTS

D2.5.1 TESTING

All tubing systems, each flared end fabricated tubing sub-assembly, and each brazed manifold assembly shall be individually hydrostatically tested before final assembly to 1-1/2 times the maximum rated pressure of the tubing as specified by KSC-SPEC-Z-0008 and/or KSC-SPEC-Z-0005 (reference KSC-SPEC-Z-0005 Paragraph 4.3.3 for gas tightness).

The hydrostatic test fluid shall be demineralized water.

No components are to be hydrostatically tested in line with the tube assemblies. Pneumatic proof testing is not permitted.

D2.5.2 DOCUMENTATION

Proper documentation of hydrostatic testing shall be submitted for system files. Test reports should include the following:

- o Date of Test

- Identification for tubing sub-assembly tested (*high-lighted copy of shop drawings outlining test sections which unique identification number corresponding to test record number will be acceptable*).
- Test Fluid
- Test pressure at time intervals with test fluid temperature
- Certification of calibration of all gages utilized
- Certification of visual inspection and test results by examiner

#### D2.5.3 TUBING IDENTIFICATION

Tubing sections which have been hydrostatically tested shall be identified with an attached metal band per 75M04185 which is permanently marked with the tube size, test pressure, date of test and unique identification number corresponding to test record number.

Individual pigtailed that are brazed to a header, shall not be considered as separate tubing sections and do not require individual hydrostat identification tags. Each separate header with the attached pigtailed shall be considered as one tubing section, and after hydrostatic testing, shall be identified with an attached metal band per 75M04185 which is permanently marked with the tube size, test pressure, date of test and unique identification number corresponding to test record number.

#### D2.6 CLEANING OF TUBING/COMPONENT SYSTEMS

All tubing systems, inclusive of components, i.e., valves, regulator, filters, pressure gages, gaskets, O-rings, etc., shall be precision cleaned to meet ALL requirements of KSC-C-123F, Level 300A.

Each component must be completely disassembled and piece part cleaned by chemical vat dipping for degreasing and passivation, etc. per section 13.0 of this standard.

Components shall be reassembled by installing all new, cleaned and certified approved softgoods.

**NOTE**

*Reinstallation of elastomer seals, gaskets, etc. used in previous assemblies is prohibited. Components shall be reassembled using only approved lubricants per KSC-SPEC-Z-0009.*

**NOTE**

*If during any validation of cleanliness, the specified non volatile residue (NVR) and particulate levels are not met, then the Subcontractor will be responsible to achieve a cleanliness level of 300A.*

**D2.7 MANIFOLD ASSEMBLY INSTALLATION**

The Subcontractor shall install the trailer/MSU manifold assembly per the supplied drawing(s).

**D3.0 PNEUMATIC AND FUNCTIONAL TESTING**

**D3.1 COMPONENT LEAK TEST**

Perform a bubble tight functional leak test of reassembled components per section 11.2 of this standard. Check both internal/external leakage paths.

**D3.2 FUNCTIONAL TEST**

Subcontractor shall perform a functional test to verify proper operation of the components per section 11.2 of this standard.

**D3.3 PNEUMATIC TEST**

After final installation, Subcontractor shall perform a leak test per section 11.3 at full rated pressures using leak detection compound per MIL-L-25567. Each tube fitting and connection point shall be checked for a bubble tight fit.

**D4.0 SUBMITTALS**

**D4.1 FINAL DATA PACKAGE**

As part of final data submittal package the Subcontractor shall furnish the following documentation:

D4.1.1 AS-BUILTS

Subcontractor shall furnish complete as-built marked-up drawings for all panels. (*Red-lined drawings will suffice as meeting the above requirement.*)

D4.1.2 HYDROSTAT DOCUMENTATION

The hydrostatic test documentation, listed in paragraph D2.6.2, shall be included as part of the final data submittal package.

D4.2 CERTIFICATIONS

D4.2.1 TEST DATA

The subcontractor shall furnish the following three certifications for all testing and cleaning performed by the Subcontractor.

1. hydrostatic test
2. leakage test
3. cleanliness

D4.2.2 TUBE FLARING AND BRAZING REQUIREMENTS

The Subcontractor shall certify in writing (and demonstrate the ability) before starting work, that his personnel and procedures are capable of meeting the tube bending and flaring requirements specified in KSC-SPEC-Z-0008C and the brazing requirements specified in KSC-SPEC-Z-0005.



**22.0 APPENDIX E: CHASSIS REPLACEMENT**

**E1.0 SCOPE**

Appendix E covers the requirements for replacing trailer chassis. Chassis replacement shall be specified by the SOW. A package detailing the specific tasks required for replacing the chassis will be prepared by the contractor and that package shall be an integral part of the SOW for each trailer.

**E2.0 GENERAL REQUIREMENTS**

Except as noted in the SOW, the Subcontractor shall provide labor, materials, equipment and services required for replacing trailer chassis.

**E2.1 PRE-DELIVERY INSPECTION**

The Subcontractor shall participate in a pre-delivery inspection of the new chassis at the contractor's facility. Any discrepancies discovered during the walkdown shall be documented in the SOW.

**NOTE**

*In case of a difference or conflict between drawings and specifications, the specifications shall govern. The Subcontract Administrator shall be notified immediately of any such discrepancies as they arise.*

**E2.2 GENERAL FABRICATION REQUIREMENTS**

**E2.2.1 PREFIT AND DIMENSIONAL CHECKS**

The Subcontractor is responsible for ensuring that the chassis, crossmembers, bulkheads, cylinders, and all applicable mounting kit hardware are installed according to the applicable fabrication/assembly drawings. Actual dimensions may vary from those specified in the fabrication/assembly drawing due to cylinder locking nut placement, variation in cylinder lengths, and variation inherent to manufacturing processes. To ensure the trailer will function properly after assembly, the Subcontractor is required to fit check the new chassis, crossmembers, bulkheads, cylinders, and any mounting kit hardware prior to performing any cutting or welding on the chassis frame.

**E2.2.2 WELDING**

All welding shall be per the applicable chassis fabrication/assembly drawing. The Subcontractor is responsible for notifying the Contractor via RFI/DCN of any discrepancies noted on the applicable chassis fabrication/assembly drawings.

**E2.2.3 CYLINDER PLACEMENT**

During cylinder manufacture, an end to end bow is induced due to the force of gravity acting on the cylinder in the molten state. This is known as the line of repose. The bow in the cylinder must go down when the cylinder is mounted between bulkheads to assure proper cylinder clearance of support saddles and to preclude the potential for cylinder rotation to the low point.

**E2.2.4 CYLINDER MOUNTING SPACER PLACEMENT**

Dimensions of the new spacers/webbing shall cover the entire width of the surface they are attached to and shall be sufficient to protect the cylinders from any metal to metal contact. In some cases it may be necessary to add multiple layers of the belting.

**E2.3 DOCUMENTATION**

**E2.3.1 AS-BUILTS**

The Subcontractor shall furnish complete as-built marked-up drawings documenting any deviations from the original drawing requirements. Redlined drawings will suffice as meeting the above requirement.

**23.0 APPENDIX F: TRAILER DATA**

KSC-SO-S-9  
REV. J

MANUFACTURER	TRAILER NUMBER	TYPE	SERVICE	CYLINDER THREAD	CYLINDER MANUFACTURER	NUMBER OF HAND VALVES	NUMBER OF HAND VALVES WITH BURST DISKS	NUMBER OF PRESSURE GAGES	NUMBER OF REGULATORS	NUMBER OF BURST DISKS	NUMBER OF CHECK VALVES	NUMBER OF FILTERS	NUMBER OF RELIEF VALVES
STNRD STL 2400 PSIG	5	I	BAIR	3/4" NGT	T. WHARTON	4	30	1	-	30	-	-	-
STNRD STL 2400 PSIG7	6	I	GH2	3/4" NGT	T. WHARTON	5	30	1	-	30	-	-	-
STNRD STL 2400 PSIG	7	I	BAIR	3/4" NGT	T. WHARTON	4	30	1	-	30	-	-	-
STNRD STL 2400 PSIG	8	I	GH2	3/4" NGT	T. WHARTON	5	30	1	-	30	-	-	-
STNRD STL 2400 PSIG	9	I	BAIR	3/4" NGT	T. WHARTON	4	30	1	-	30	-	-	-
STNRD STL 2400 PSIG	10	I	BAIR	3/4" NGT	T. WHARTON	4	30	1	-	30	-	-	-
STNRD STL 2400 PSIG	11	I	BAIR	3/4" NGT	T. WHARTON	4	30	1	-	30	-	-	-
STNRD STL 2400 PSIG	12	I	GO2	3/4" NGT	T. WHARTON	4	30	1	-	30	-	-	-
STNRD STL 2400 PSIG	13	I	BAIR	3/4" NGT	T. WHARTON	4	30	1	-	30	-	-	-
STNRD STL 2400 PSIG	14	I	BAIR	3/4" NGT	T. WHARTON	4	30	1	-	30	-	-	-
STNRD STL 2400 PSIG	16	I	BAIR	3/4" NGT	T. WHARTON	4	30	1	-	30	-	-	-
STNRD STL 2400 PSIG	18	I	GN2	3/4" NGT	T. WHARTON	4	30	1	-	30	-	-	-
STNRD STL 2400 PSIG	19	I	GN2	3/4" NGT	T. WHARTON	4	30	1	-	30	-	-	-
STNRD STL 2400 PSIG	20	I	GN2	3/4" NGT	T. WHARTON	4	30	1	-	30	-	-	-
STNRD STL 2400 PSIG	21	I	GN2	3/4" NGT	T. WHARTON	4	30	1	-	30	-	-	-

KSC-SO-S-9  
REV. J

MANUFACTURER	TRAILER NUMBER	TYPE	SERVICE	CYLINDER THREAD	CYLINDER MANUFACTURER	NUMBER OF HAND VALVES	NUMBER OF HAND VALVES WITH BURST DISKS	NUMBER OF PRESSURE GAGES	NUMBER OF REGULATORS	NUMBER OF DOME REGULATORS	NUMBER OF BURST DISKS	NUMBER OF CHECK VALVES	NUMBER OF FILTERS	NUMBER OF RELIEF VALVES
STNRD STL 2400 PSIG	23	I	GN2	3/4" NGT	T. WHARTON	4	30	1	-	-	30	-	-	-
STNRD STL 2400 PSIG7	24	I	GN2	3/4" NGT	T. WHARTON	4	30	1	-	-	30	-	-	-
STNRD STL 2400 PSIG	25	I	GO2	3/4" NGT	T. WHARTON	4	30	1	-	-	30	-	-	-
STNRD STL 2400 PSIG	26	I	GO2	3/4" NGT	T. WHARTON	4	30	1	-	-	30	-	-	-
STNRD STL 2400 PSIG	27	I	GO2	3/4" NGT	T. WHARTON	4	30	1	-	-	30	-	-	-
STNRD STL 2400 PSIG	28	I	GN2	3/4" NGT	T. WHARTON	4	30	1	-	-	30	-	-	-
EIDAL 2400 PSIG	34	II	GN2	3/4" NGT	U.S. STEEL	14	1	1	-	-	20	-	-	-
EIDAL 2400 PSIG	35	II	GN2	3/4" NGT	U.S. STEEL	14	1	1	-	-	20	-	-	-
EIDAL 2400 PSIG	36	II	GN2	3/4" NGT	U.S. STEEL	14	1	1	-	-	20	-	-	-
EIDAL 2400 PSIG	37	II	GN2	3/4" NGT	U.S. STEEL	14	1	1	-	-	20	-	-	-
EIDAL 2400 PSIG	38	II	GN2	3/4" NGT	U.S. STEEL	14	1	1	-	-	20	-	-	-
EIDAL 2400 PSIG	39	II	GN2	3/4" NGT	U.S. STEEL	14	1	1	-	-	20	-	-	-
EIDAL 2400 PSIG	40	II	GN2	3/4" NGT	U.S. STEEL	14	1	1	-	-	20	-	-	-
EIDAL 2400 PSIG	41	II	GN2	3/4" NGT	U.S. STEEL	14	1	1	-	-	20	-	-	-
EIDAL 2400 PSIG	42	II	GN2	3/4" NGT	U.S. STEEL	14	1	1	-	-	20	-	-	-

KSC-SO-S-9  
REV. J

MANUFACTURER	TRAILER NUMBER	TYPE	SERVICE	CYLINDER THREAD	CYLINDER MANUFACTURER	NUMBER OF HAND VALVES	NUMBER OF HAND VALVES WITH BURST DISKS	NUMBER OF PRESSURE GAGES	NUMBER OF REGULATORS	NUMBER OF DOME REGULATORS	NUMBER OF BURST DISKS	NUMBER OF CHECK VALVES	NUMBER OF FILTERS	NUMBER OF RELIEF VALVES
EIDAL 2400 PSIG	43	I	GH <sub>e</sub>	3/4" NGT	U.S. STEEL	14	1	1	-	-	20	-	-	-
EIDAL 2400 PSIG	44	I	GH <sub>e</sub>	3/4" NGT	U.S. STEEL	14	1	1	-	-	20	-	-	-
EIDAL 2400 PSIG	45	I	GH <sub>e</sub>	3/4" NGT	U.S. STEEL	14	1	1	-	-	20	-	-	-
EIDAL 2400 PSIG	46	I	GH <sub>e</sub>	3/4" NGT	U.S. STEEL	14	1	1	-	-	20	-	-	-
EIDAL 2400 PSIG	47	I	GO2	3/4" NGT	U.S. STEEL	14	1	1	-	-	20	-	-	-
EIDAL 2400 PSIG	48	I	GN2	3/4" NGT	U.S. STEEL	14	1	1	-	-	20	-	-	-
EIDAL 2400 PSIG	49	II	GN2	3/4" NGT	U.S. STEEL	14	1	1	-	-	20	-	-	-
EIDAL 2400 PSIG	50	II	GH <sub>e</sub>	3/4" NGT	U.S. STEEL	14	1	1	-	-	20	-	-	-
EIDAL 2400 PSIG	51	II	GN2	3/4" NGT	U.S. STEEL	14	1	1	-	-	20	-	-	-
EIDAL 2400 PSIG	52	II	GH <sub>e</sub>	3/4" NGT	U.S. STEEL	14	1	1	-	-	20	-	-	-
EIDAL 2400 PSIG	53	II	GH <sub>e</sub>	3/4" NGT	U.S. STEEL	14	1	1	-	-	20	-	-	-
EIDAL 2400 PSIG	61	III	GH <sub>e</sub>	3 1/4 -8N-3B	U.S. STEEL	17	-	2	1	1	9	1	-	10
EIDAL 6000 PSIG	62	III	GH <sub>e</sub>	3 1/4 -8N-3B	U.S. STEEL	17	-	2	1	1	10	1	-	10
EIDAL 6000 PSIG	63	III	GN2	3 1/4 -8N-3B	U.S. STEEL	17	-	2	1	1	9	-	-	9
EIDAL 6000 PSIG	64	III	GN2	3 1/4 -8N-3B	U.S. STEEL	17	-	2	1	1	9	-	-	9

KSC-SO-S-9  
REV. J

MANUFACTURER	TRAILER NUMBER	TYPE	SERVICE	CYLINDER THREAD	CYLINDER MANUFACTURER	NUMBER OF HAND VALVES	NUMBER OF HAND VALVES WITH BURST DISKS	NUMBER OF PRESSURE GAUGES	NUMBER OF REGULATORS	NUMBER OF DOME REGULATORS	NUMBER OF BURST DISKS	NUMBER OF CHECK VALVES	NUMBER OF FILTERS	NUMBER OF RELIEF VALVES
AMER CRYO 6000 PSIG	65	III	GN2	3 1/4 -8N-3B	U.S. STEEL	17	-	2	1	1	10	-	-	9
AMER CRYO 6000 PSIG	66	III	GN2	3 1/4 -8N-3B	U.S. STEEL	17	-	2	1	1	10	-	-	9
AMER CRYO 6000 PSIG	67	III	GN2	3 1/4 -8N-3B	U.S. STEEL	17	-	2	1	1	10	-	-	9
AMER CRYO 6000 PSIG	68	III	GN2	3 1/4 -8N-3B	U.S. STEEL	17	-	2	1	1	10	-	-	9
COSMODYNE 6000 PSIG	69	IX	GN2	3 1/4 -8N-3B	U.S. STEEL	17	-	2	1	1	9	-	-	10
COSMODYNE 6000 PSIG	70	IX	GN2	3 1/4 -8N-3B	U.S. STEEL	17	-	2	1	1	9	-	-	10
EIDAL 10,000 PSIG	71	IV	GH6	3 1/4 -8N-3B	U.S. STEEL	17	-	2	1	1	9	-	-	9
EIDAL 10,000 PSIG	72	IV	GN2	3 1/4 -8N-3B	U.S. STEEL	17	-	2	1	1	9	-	-	9
AMER CRYO 10,000 PSIG	73	IV	GN2	3 1/4 -8N-3B	U.S. STEEL	17	-	2	1	1	9	-	-	9
COSMODYNE 10,000 PSIG	74	VIII	GO2	3 1/4 -8N-3B	U.S. STEEL	17	-	2	1	1	9	-	-	9
EIDAL 15,000 PSIG	76	V	GN2	3 1/4 -8N-3B	U.S. STEEL	17	-	2	1	1	9	-	-	9
THICKOL 6000 PSIG	80	VI	GO2	3/4" NGT	MARISON	6	24	2	1	-	-	-	-	24
THICKOL 6000 PSIG	81	VI	GO2	3/4" NGT	MARISON	6	24	2	1	-	-	-	1	24
THICKOL 6000 PSIG	82	VI	GO2	3/4" NGT	MARISON	6	24	2	1	-	-	-	1	24
DOUGLAS 2400 PSIG	101	I	GN2	3/4" NGT	MARISON	5	38	1	-	-	38	-	-	-

KSC-SO-S-9  
REV. J

MANUFACTURER	TRAILER NUMBER	TYPE	SERVICE	CYLINDER THREAD	CYLINDER MANUFACTURER	NUMBER OF HAND VALVES	NUMBER OF HAND VALVES WITH BURST DISKS	NUMBER OF PRESSURE GAGES	NUMBER OF REGULATORS	NUMBER OF DOCK REGULATORS	NUMBER OF BURST DISKS	NUMBER OF CHECK VALVES	NUMBER OF FILTERS	NUMBER OF RELIEF VALVES
DOUGLAS 2400 PSIG	102	I	GN2	3/4" NGT	MARISON	5	38	1	.	.	38	.	.	.
DOUGLAS 2400 PSIG	111	I	GH6	3/4" NGT	MARISON	5	38	1	.	.	38	.	.	.
DOUGLAS 2400 PSIG	114	I	GH6	3/4" NGT	MARISON	5	38	1	.	.	38	.	.	.
DOUGLAS 2400 PSIG	119	I	GH6	3/4" NGT	MARISON	5	38	1	.	.	38	.	.	.
DOUGLAS 2400 PSIG	120	I	GH6	3/4" NGT	MARISON	5	38	1	.	.	38	.	.	.
DOUGLAS 2400 PSIG	121	I	GH6	3/4" NGT	MARISON	5	38	1	.	.	38	.	.	.
DOUGLAS 2400 PSIG	124	I	GH6	3/4" NGT	MARISON	5	38	1	.	.	38	.	.	.
DOUGLAS 2400 PSIG	126	I	GH6	3/4" NGT	MARISON	5	38	1	.	.	38	.	.	.
DOUGLAS 2400 PSIG	127	I	GH6	3/4" NGT	MARISON	5	38	1	.	.	38	.	.	.
DOUGLAS 2400 PSIG	133	I	GH6	3/4" NGT	MARISON	5	38	1	.	.	38	.	.	.
DOUGLAS 2400 PSIG	136	I	GH6	3/4" NGT	MARISON	5	38	1	.	.	38	.	.	.
STNRD STL 2400 PSIG	151	I	GN2	3/4" NGT	T. WHARTON	4	38	1	.	.	38	.	.	.
STNRD STL 2400 PSIG	152	I	GN2	3/4" NGT	T. WHARTON	4	38	1	.	.	38	.	.	.
STNRD STL 2400 PSIG	153	I	GN2	3/4" NGT	T. WHARTON	4	38	1	.	.	38	.	.	.
STNRD STL 2400 PSIG	154	I	GN2	3/4" NGT	T. WHARTON	4	38	1	.	.	38	.	.	.



MANUFACTURER	TRAILER NUMBER	TYPE	SERVICE	CYLINDER THREAD	CYLINDER MANUFACTURER	NUMBER OF HAND VALVES	NUMBER OF HAND VALVES WITH BURST DISKS	NUMBER OF PRESSURE GAGES	NUMBER OF REGULATORS	NUMBER OF DOME REGULATORS	NUMBER OF BURST DISKS	NUMBER OF CHECK VALVES	NUMBER OF FILTERS	NUMBER OF RELIEF VALVES
STNRD STL 2400 PSIG	155	I	GN2	3/4" NGT	T. WHARTON	4	30	1	-	-	38	-	-	-
STNRD STL 2400 PSIG	156	I	GN2	3/4" NGT	T. WHARTON	7	38	1	-	-	38	-	-	-
STNRD STL 2400 PSIG	157	I	GHe	3/4" NGT	T. WHARTON	7	38	1	-	-	38	-	-	-
STNRD STL 2400 PSIG	158	I	GHe	3/4" NGT	T. WHARTON	7	38	1	-	-	38	-	-	-
STNRD STL 2400 PSIG	159	I	GHe	3/4" NGT	T. WHARTON	7	38	1	-	-	38	-	-	-
STNRD STL 2400 PSIG	160	I	GHe	3/4" NGT	T. WHARTON	7	38	1	-	-	38	-	-	-
STNRD STL 2400 PSIG	161	I	GHe	3/4" NGT	T. WHARTON	7	38	1	-	-	38	-	-	-
STNRD STL 2400 PSIG	162	I	GHe	3/4" NGT	T. WHARTON	7	38	1	-	-	38	-	-	-
STNRD STL 2400 PSIG	163	I	GHe	3/4" NGT	T. WHARTON	7	38	1	-	-	38	-	-	-
STNRD STL 2400 PSIG	164	I	BAIR	3/4" NGT	T. WHARTON	4	30	1	-	-	38	-	-	-

KSC-SO-S-9  
REV. J

MANUFACTURER	MSJ NUMBER	# OF CYL	SERVICE	CYLINDER THREAD	CYLINDER MANUFACTURER	NUMBER OF HAND VALVES	NUMBER OF HAND VALVES WITH BURST DISKS	NUMBER OF PRESSURE GAGES	NUMBER OF REGULATORS	NUMBER OF DOME REGULATORS	NUMBER OF BURST DISKS	NUMBER OF CHECK VALVES	NUMBER OF FILTERS	NUMBER OF RELIEF VALVES
U.S. STEEL 2400 PSIG	176	4	GN2	5"-8N-2A 2 3/4" -8N-2B	U.S. STEEL	10	2	1	-	-	9	-	-	-
U.S. STEEL 2400 PSIG	177	4	GN2	5"-8N-2A 2 3/4" -8N-2B	U.S. STEEL	10	2	1	-	-	9	-	-	-
U.S. STEEL 2400 PSIG	178	4	GN2	5"-8N-2A 2 3/4" -8N-2B	U.S. STEEL	10	2	1	-	-	9	-	-	-
U.S. STEEL 2400 PSIG	179	4	GN2	5"-8N-2A 2 3/4" -8N-2B	U.S. STEEL	10	2	1	-	-	9	-	-	-
U.S. STEEL 2400 PSIG	180	4	GN2	5"-8N-2A 2 3/4" -8N-2B	U.S. STEEL	10	2	1	-	-	9	-	-	-
U.S. STEEL 2400 PSIG	181	4	BAIR	5"-8N-2A 2 3/4" -8N-2B	U.S. STEEL	10	2	1	-	-	9	-	-	-
U.S. STEEL 2400 PSIG	182	4	BAIR	5"-8N-2A 2 3/4" -8N-2B	U.S. STEEL	10	2	1	-	-	9	-	-	-
U.S. STEEL 2400 PSIG	183	4	GH6	5"-8N-2A 2 3/4" -8N-2B	U.S. STEEL	10	2	1	-	-	9	-	-	-
U.S. STEEL 2400 PSIG	184	4	BAIR	5"-8N-2A 2 3/4" -8N-2B	U.S. STEEL	10	2	1	-	-	9	-	-	-
U.S. STEEL 2400 PSIG	185	4	BAIR	5"-8N-2A 2 3/4" -8N-2B	U.S. STEEL	10	2	1	-	-	9	-	-	-
U.S. STEEL 2400 PSIG	186	4	GH6	5"-8N-2A 2 3/4" -8N-2B	U.S. STEEL	10	2	1	-	-	9	-	-	-
U.S. STEEL 2400 PSIG	187	4	BAIR	5"-8N-2A 2 3/4" -8N-2B	U.S. STEEL	10	2	1	-	-	9	-	-	-
U.S. STEEL 2400 PSIG	188	4	GN2	5"-8N-2A 2 3/4" -8N-2B	U.S. STEEL	10	2	1	-	-	9	-	-	-
U.S. STEEL 2400 PSIG	189	4	GN2	5"-8N-2A 2 3/4" -8N-2B	U.S. STEEL	10	2	1	-	-	9	-	-	-
U.S. STEEL 2400 PSIG	190	4	GN2	5"-8N-2A 2 3/4" -8N-2B	U.S. STEEL	10	2	1	-	-	9	-	-	-

KSC-SO-S-9  
REV. J

MANUFACTURER	NSU NUMBER	# OF CYL	SERVICE	CYLINDER THREAD	CYLINDER MANUFACTURER	NUMBER OF HAND VALVES	NUMBER OF HAND VALVES WITH BURST DISKS	NUMBER OF PRESSURE GAGES	NUMBER OF REGULATORS	NUMBER OF DOME REGULATORS	NUMBER OF BURST DISKS	NUMBER OF CHECK VALVES	NUMBER OF FILTERS	NUMBER OF RELIEF VALVES
U.S. STEEL 2400 PSIG	191	4	GN2	5'-8N-2A 2 1/2" -8N-2B	U.S. STEEL	10	2	1	-	-	9	-	-	-
U.S. STEEL 2400 PSIG	192	2	GN2	5'-8N-2A 2 1/2" -8N-2B	U.S. STEEL	8	2	1	-	-	5	-	-	-
U.S. STEEL 2400 PSIG	193	4	GN2	5'-8N-2A 2 1/2" -8N-2B	U.S. STEEL	10	2	1	-	-	9	-	-	-
U.S. STEEL 2400 PSIG	194	4	GN2	5'-8N-2A 2 1/2" -8N-2B	U.S. STEEL	10	2	1	-	-	9	-	-	-
U.S. STEEL 2400 PSIG	195	4	BAIR	5'-8N-2A 2 1/2" -8N-2B	U.S. STEEL	10	2	1	-	-	9	-	-	-
U.S. STEEL 2400 PSIG	196	4	BAIR	5'-8N-2A 2 1/2" -8N-2B	U.S. STEEL	10	2	1	-	-	9	-	-	-
BOM 2400 PSIG	201	2	GN2	2'-11 1/2 NPT 7-8 M	U.S. STEEL	6	1	1	-	-	2	-	-	1
BOM 2400 PSIG	202	2	GH9	2'-11 1/2 NPT 7-8 M	U.S. STEEL	6	1	1	-	-	2	-	-	1
BOM 2400 PSIG	203	2	GH9	2'-11 1/2 NPT 7-8 M	U.S. STEEL	6	1	1	-	-	2	-	-	1
BOM 2400 PSIG	204	2	GN2	2'-11 1/2 NPT 7-8 M	U.S. STEEL	6	1	1	-	-	2	-	-	1
BOM 2400 PSIG	205	2	GN2	2'-11 1/2 NPT 7-8 M	U.S. STEEL	6	1	1	-	-	2	-	-	1
BOM 2400 PSIG	206	2	GN2	2'-11 1/2 NPT 7-8 M	U.S. STEEL	6	1	1	-	-	2	-	-	1
BOM 2400 PSIG	207	2	GN2	2'-11 1/2 NPT 7-8 M	U.S. STEEL	6	1	1	-	-	2	-	-	1
BOM 2400 PSIG	208	2	GN2	2'-11 1/2 NPT 7-8 M	U.S. STEEL	6	1	1	-	-	2	-	-	1
BOM 2400 PSIG	209	2	GH9	2'-11 1/2 NPT 7-8 M	U.S. STEEL	6	1	1	-	-	2	-	-	1

MANUFACTURER	MSU NUMBER	# OF CYL	SERVICE	CYLINDER THREAD	CYLINDER MANUFACTURER	NUMBER OF HAND VALVES	NUMBER OF HAND VALVES WITH BURST DISK	NUMBER OF PRESSURE GAGES	NUMBER OF REGULATORS	NUMBER OF DOME REGULATORS	NUMBER OF BURST DISKS	NUMBER OF CHECK VALVES	NUMBER OF FILTERS	NUMBER OF RELIEF VALVES
BOM 2400 PSIG	210	2	GN2	2"-11½ NPT 7-8 M	U.S. STEEL	6	1	1	·	·	2	·	·	1
BOM 2400 PSIG	211	2	GH6	2"-11½ NPT 7-8 M	U.S. STEEL	6	1	1	·	·	2	·	·	1
BOM 2400 PSIG	212	2	GN2	2"-11½ NPT 7-8 M	U.S. STEEL	6	1	1	·	·	2	·	·	1
U.S. STEEL 2400 PSIG	301	0	GN2	2"-11½ NPT 7-8 M	U.S. STEEL	6	·	1	·	·	·	·	·	2
U.S. STEEL 2400 PSIG	302	2	GO2	2"-11½ NPT 7-8 M	U.S. STEEL	·	·	·	·	·	·	·	·	·
U.S. STEEL 2400 PSIG	304	0	BAIR	2"-11½ NPT 7-8 M	U.S. STEEL	·	·	·	·	·	·	·	·	1

**24.0 APPENDIX G: TABLES/FIGURES**

**TABLE 1**  
**TRAILER/MSU TYPES**  
**NASA, KENNEDY SPACE CENTER, FLA.**  
(Page 1 of 5)

NOMENCLATURE	TYPE I	TYPE II	TYPE III
<u>Trailer</u>			
Manufacturer(s)	Stndrd Stl, Douglas	Eidal	Eidal, Amer. Cryo
Length, FT-IN.	25-0	36-4	34-4
Width, FT-IN.	8-0	8-0	8-0
Height, Ft-IN.	8-11	9-10	8-7
Weight, LBS., Tare	33,700/34,460	57,800	54,800/54,500
Axles	Tandem	Tandem	Tandem
Wheels	Dual	Dual	Dual
Kingpin Load, LBS.	9,000/8300	25,000	22,800/24,000
No. of Cylinders	38	10	9
<u>Cylinders</u>			
Manufacturer	Marison/T. Wharton	U.S. Steel	U.S. Steel
Length, FT-IN.	21-0	34-4	30-7
Diameter, OD-IN.	9.625	22.0	12.75
Min. Design Wall Thk, IN.	0.300	0.536	1.123
Approximate Weight, LBS.	700	4,800	4,800
Liquid Volume, FT <sup>3</sup>	9.1	77.6	16.47
Working Pressure, PSI	2,400	2,400	6,000
Test Pressure, PSI	4,000	4,000	10,000
Type Lining	None	None	Epoxy
Ext. Surface Area, FT <sup>2</sup>	53	196	101
Int. Surface Area, FT <sup>2</sup>	49	187	84
Mounting	Retaining Nuts	Flanges	Flanges
"O" Ring-Part No.	None	2MP2165A	2MP2165A
Back-Up Ring-Part No.	None	2MP2511	2MP2511
<u>Other Data</u>			
Relief Valve Setting, PSI	None	None	6600 ± 200 Burst
Disc Rating, PSI @ 72°	3600-4000	3600-4000	7500-8500
No. of Hand Valves	43	15	17
No. of Gages	1	1	2
No. of Regulators	0	0	1
No. of Burst Discs	77	21	10
No. of Dome Regulators	0	0	1
No. of Relief Valves	0	0	9

**TABLE 1**  
**TRAILER/MSU TYPES**  
**NASA, KENNEDY SPACE CENTER, FLA.**  
(Page 2 of 5)

NOMENCLATURE	TYPE IV	TYPE V	TYPE VI
<u>Trailer</u>			
Manufacturer(s)	Eidal, Amer. Cryo	Eidal	Thiokol
Length, FT-IN.	34-4	32-3	32
Width, FT-IN.	8-0	8-0	7-11
Height, FT-IN	8-7	8-7	8-0
Weight, LBS., Tare	56,750/55,900	54,550	54,100
Axles	Tandem	Tandem	Tandem
Wheels	Dual	Dual	Dual
Kingpin Load, LBS.	21,850/24,500	15,650	22,700
No. of Cylinders	9	9	24
<u>Cylinders</u>			
Manufacturer	U.S. Steel	U.S. Steel	Marison
Length, FT-IN.	28-5	20-0	28-3
Diameter, OD-IN.	12.75	12.75	9.635
Min. Design Wall Thk, In	1.218	1.760	1
Approximate Weight, LBS.	4,800	4,800	1,600
Liquid Volume, FT <sup>3</sup>	14.6	7.71	10.4
Working Pressure, PSI	10,000	15,000	6,000
Test Pressure, PSI	16,667	25,000	10,000
Type Lining	Epoxy	Epoxy	None
Ext. Surface Area, FT <sup>2</sup>	95	56	71
Int. Surface Area, FT <sup>2</sup>	82	41	61
Mounting	Flanges	Flanges	Retaining Nuts
"O" Ring-Part No.	2MP2165A	2MP2165A	None
Back-Up Ring-Part No.	2MP2511	2MP2511	None
<u>Other Data</u>			
Relief Valve Setting, PSI	11,000 ± 200	16,500 ± 400	6,600 ± 200
Burst Disc Rating, PSI @ 72°	11,800-13,000	18,000-19,500	7,000-9,000
No. of Hand Valves	17	17	30
No. of Gages	2	2	2
No. of Regulators	1	1	1
No. of Burst Discs	9	9	24
No. of Dome Regulators	1	1	0
No. of Relief Valves	9	9	24

**TABLE 1**  
**TRAILER/MSU TYPES**  
**NASA, KENNEDY SPACE CENTER, FLA.**  
(Page 3 of 5)

NOMENCLATURE	TYPE VIII	TYPE IX
<u>Trailer</u>		
Manufacturer(s)	Cosmodyne	Cosmodyne
Length, FT-IN	34-0	35-0
Width, FT-IN	8-0	8-0
Height, FT-IN	8-7	8-7
Weight, LBS., Tare	56,300	57,300
Wheels	Dual	Dual
Axles	Tandem	Tandem
Kingpin Load, LBS.	24,100	23,300
No. of Cylinders	9	9
<u>Cylinders</u>		
Manufacturer	U.S. Steel	U.S. Steel
Length, FT-IN.	28-5	30-7
Diameter, OD-IN.	12.75	12.75
Min. Design Wall Thk-IN.	1.218	1.123
Approximate Weight, LBS.	4, 800	4,800
Liquid Volume, FT <sup>3</sup>	14.6	16.47
Working Pressure, PSI	10,000	6,000
Test Pressure, PSI	16,667	10,000
Type Lining	None	None
Ext. Surface Area, FT <sup>2</sup>	95	101
Int. Surface Area, FT <sup>2</sup>	82	84
Mounting	Flanges	Flanges
"O" Ring P/N	2-237T	2MP2165A
Back-Up Ring P/N	TF-699	2MP2511
<u>Other Data</u>		
Relief Valve Setting, PSI	11,000 + 0, - 200	6,600 ± 200, 100 ± 5
Burst Disc Rating PSI @ 72°	11,800-13,200	7,500-8,500
No. of Hand Valves	17	17
No. of Gages	2	2
No. of Regulators	1	1
No. of Burst Discs	9	9
No. of Dome Regulators	1	1
No. of Relief Valves	9	9, 1



**TABLE 1**  
**TRAILER/MSU TYPES**  
**NASA, KENNEDY SPACE CENTER, FLA.**  
(Page 4 of 5)

NOMENCLATURE	100 Series MSU's	200 Series MSU's
<u>MSU</u>		
Manufacturer(s)	U. S. Steel Corporation	U. S. Steel Corporation
Length, FT-IN.	30-4	34-8
Width, FT-IN.	7-7	2-4
Height, FT-IN	5-6	4-6
Weight, LBS., Tare	21,500	10,000
No. of Cylinders	4 or 2	2
<u>Cylinders</u>		
Manufacturer	U.S. Steel Corporation	U.S. Steel Corporation
Length, FT-IN	28	33
Diameter, OD-IN	24	18
Min. Design Wall Thk, IN.	0.584	0.826
Approximate Weight, LBS.	4,640	4,950
Liquid Volume, FT <sup>3</sup>	74.51	44.8
Working Pressure, PSI.	2400	2400
Test Pressure, PSI	4000	4000
Type Lining	None	None
Ext. Surface Area, FT <sup>2</sup>	177	
Int. Surface Area, FT <sup>2</sup>	168	
Mounting	Flange	Neck
"O" Rings - Part No.	2MP1418 Silver Solder (Ring)	Copper (Gasket)
Back-up Ring - Part No.	2MP1406 Copper (Gasket)	
<u>Other Data</u>		
Relief Valve Setting, PSIG	None	None
Burst Disc Rating	4,000±160	3,350±160
No. of Hand Valves	10	6
No. of Gages	1	1
No of Regulators	0	0
No of Burst Discs	9	2
No of Dome Regulators	0	0
No of Relief Valves	0	1

**TABLE 1**  
**TRAILER/MSU TYPES**  
**NASA, KENNEDY SPACE CENTER, FLA.**  
(Page 5 of 5)

NOMENCLATURE	300 Series MSU's	
<u>MSU</u>	301 & 304	302
Manufacturer(s)	U. S. Steel Corporation	U. S. Steel Corporation
Length, FT-IN.	26	25
Width, FT-IN.	4-2	2
Height, FT-IN	5-4	5
Weight, LBS., Tare	49,120	10,376
No. of Cylinders	9	2
<u>Cylinders</u>		
Manufacturer	U.S. Steel Corporation	U.S. Steel Corporation
Length, FT-IN	22-10	22-10
Diameter, OD-IN	16	16
Min. Design Wall Thk, IN.	1.132	1.132
Approximate Weight, LBS.	4,860	4,860
Liquid Volume, FT <sup>3</sup>	22.22	22.22
Working Pressure, PSI.	5000	5000
Test Pressure, PSI	7500	7500
Type Lining	None	None
Ext. Surface Area, FT <sup>2</sup>		
Int. Surface Area, FT <sup>2</sup>		
Mounting	Bulkhead Neck Support	Bulkhead Neck Support
"O" Rings - Part No.		
Back-up Ring - Part No.		
<u>Other Data</u>		
Relief Valve Setting, PSIG	301 Only, 81K00965	None
Burst Disc Rating	None	None
No. of Hand Valves	6 (301 Only)	
No. of Gages	1 (301 Only)	
No of Regulators	0	
No of Burst Discs	0	
No of Dome Regulators	0	
No of Relief Valves	2 (301 Only)	

**TABLE 2  
WELDING ALLOWABLE DEFECT LIMITS  
NASA, KENNEDY SPACE CENTER, FLA.**

DEFECT	LIMIT	T= THICKNESS OF BASE METAL
1. Cracks	None	
2. Mismatch	20%T or 0.15 inch <u>1/</u>	
3. Porosity Open to Surface	4 per inch <u>2/</u> 0.2 inch min. spacing	
4. Undercut	20%T or 0.05 inch <u>1/</u> 5T max. length	
5. Incomplete <u>3/</u>	20%T or 0.05 inch Depth <u>1/</u> 4T max. length	
6. Cold Shut <u>3/</u>	2T max. length	
7. Overlap <u>3/</u>	2T max. length	
8. Concavity	20%T or 0.09 inch depth <u>1/</u> 1T max. length	
9. Craters	20%T or 0.09 inch Depth <u>1/</u> 2T max. length	
10. Underbead Drop through	Clearance for mating parts	
11. Thinning	Not less than 80%T or 0.05 inch <u>1/</u> 5T length	
12. Accumulation of defects 3 to 10 inclusive	4T minimum between any two defects	

1/ Whichever is the lesser

2/ Maximum size 30 percent of "T" or 0.10 inch, whichever is the lesser

3/ If these defects exhibit sharp radii, sharp terminations or crack like appearance, they shall be removed by grinding. If depression is not larger than permitted, they need not be rewelded.

TABLE 3  
APPROVED COATINGS PRODUCT LIST

PRIMER	INTERMEDIATE COAT	FINISH COAT	MANUFACTURER
519	1447	428	Engard Coatings 15541 Commerce Ln Huntington Bch, Ca 92649 (714) 891-4402
304	201	359	Devoe Marine Co. #5 Marine View Pl. Hoboken, N. J. 07030 (201) 420-8100
Zinc-Lock 311	MCR-4335	8610	Porter International 400 S. 13 Street Louisville, KY 40201 (502) 588-9200
D6	Amercoat 182 HS	Amercoat 450 HS, WH-1	Ameron P.C.D. 201 N. Berry St. Brea, Ca. 92691 (714) 529-1951

**NOTE**

*All coatings must be approved by NASA materials testing lab. This list is subject to change so subcontractor must obtain current list from NASA prior to selecting coating systems.*

FIGURE 1

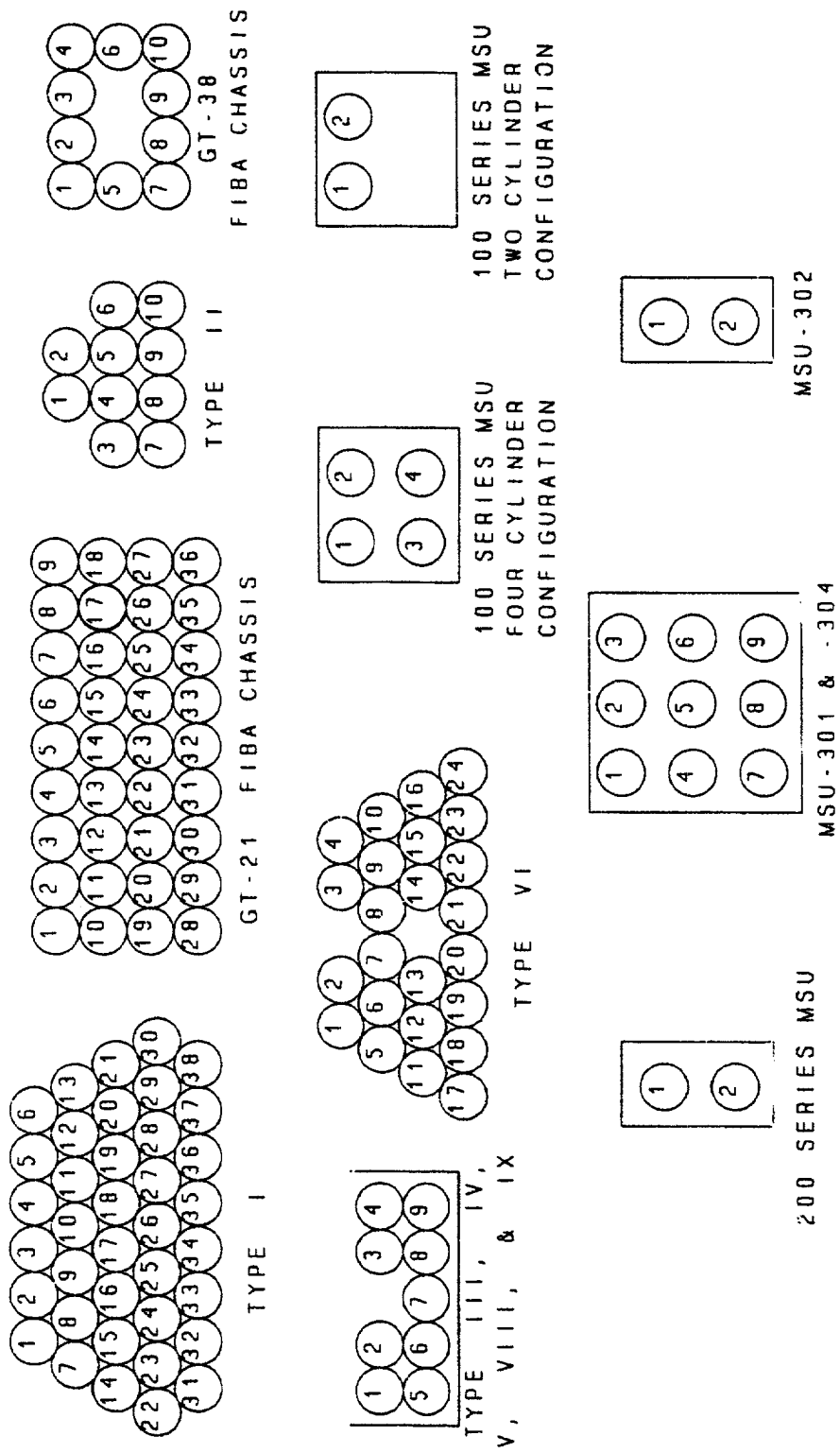

REAR VIEW ILLUSTRATING CYLINDER CONFIGURATION

FIGURE 2  
CLEANING SYSTEM SCHEMATIC

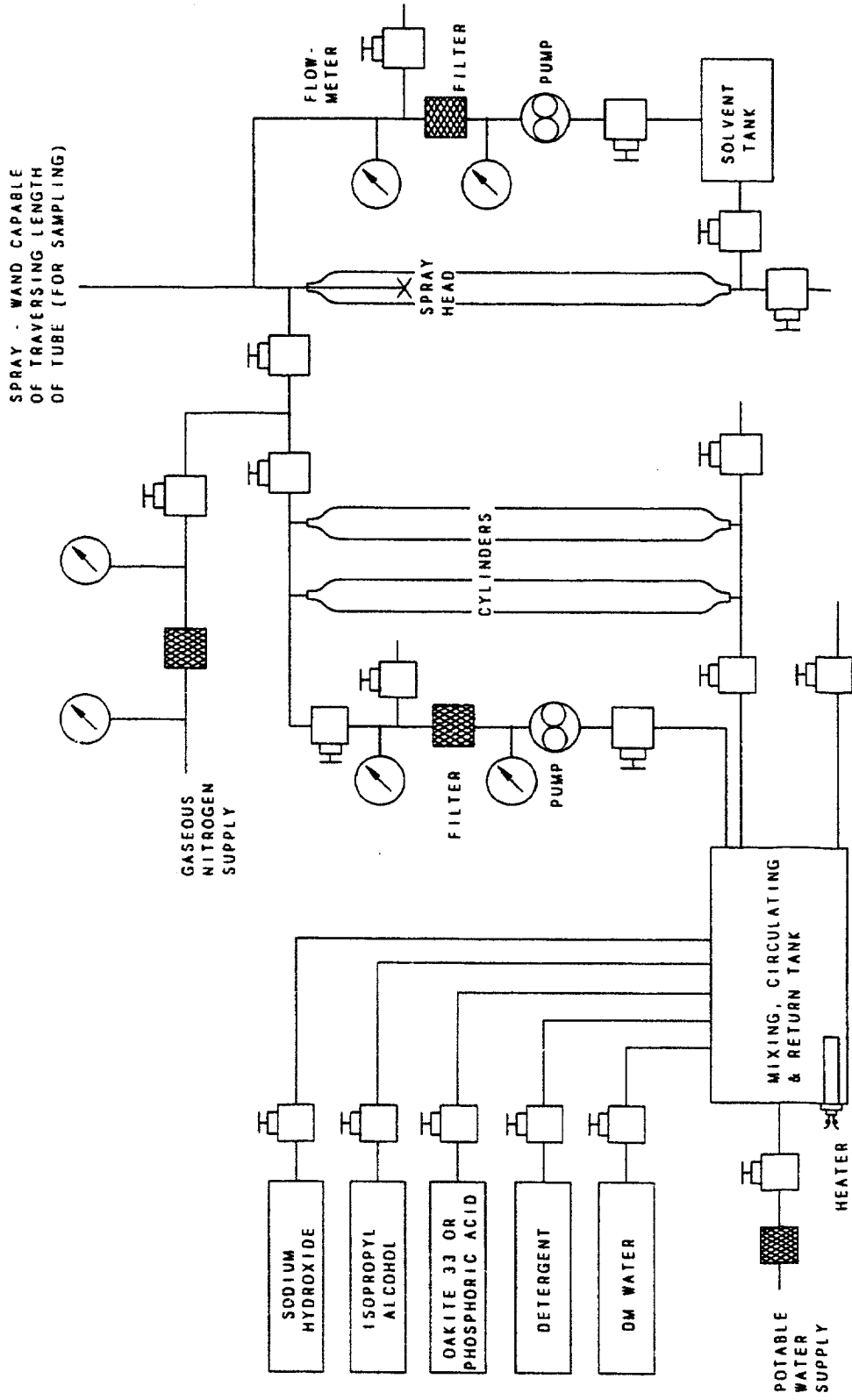

FIGURE 3  
HYDROSTATIC TEST APPARATUS SCHEMATIC

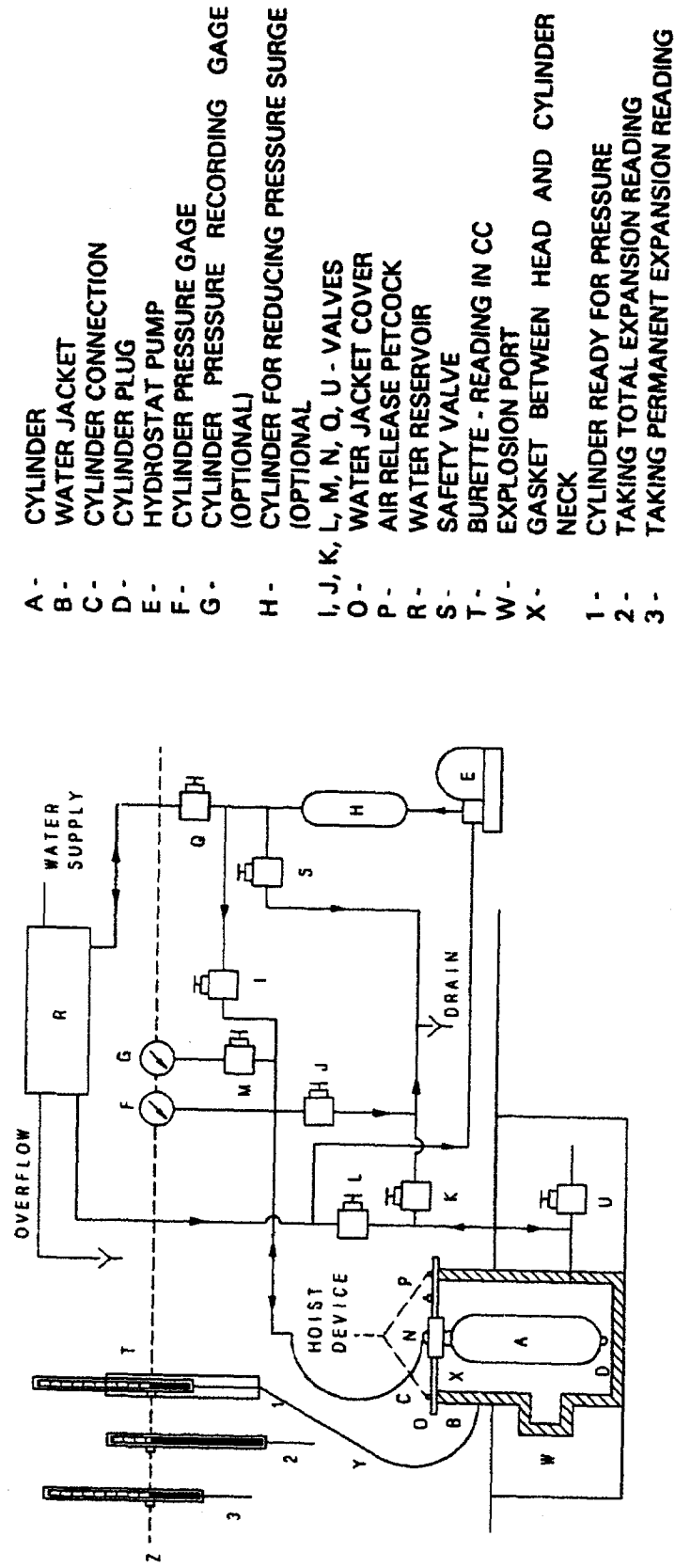
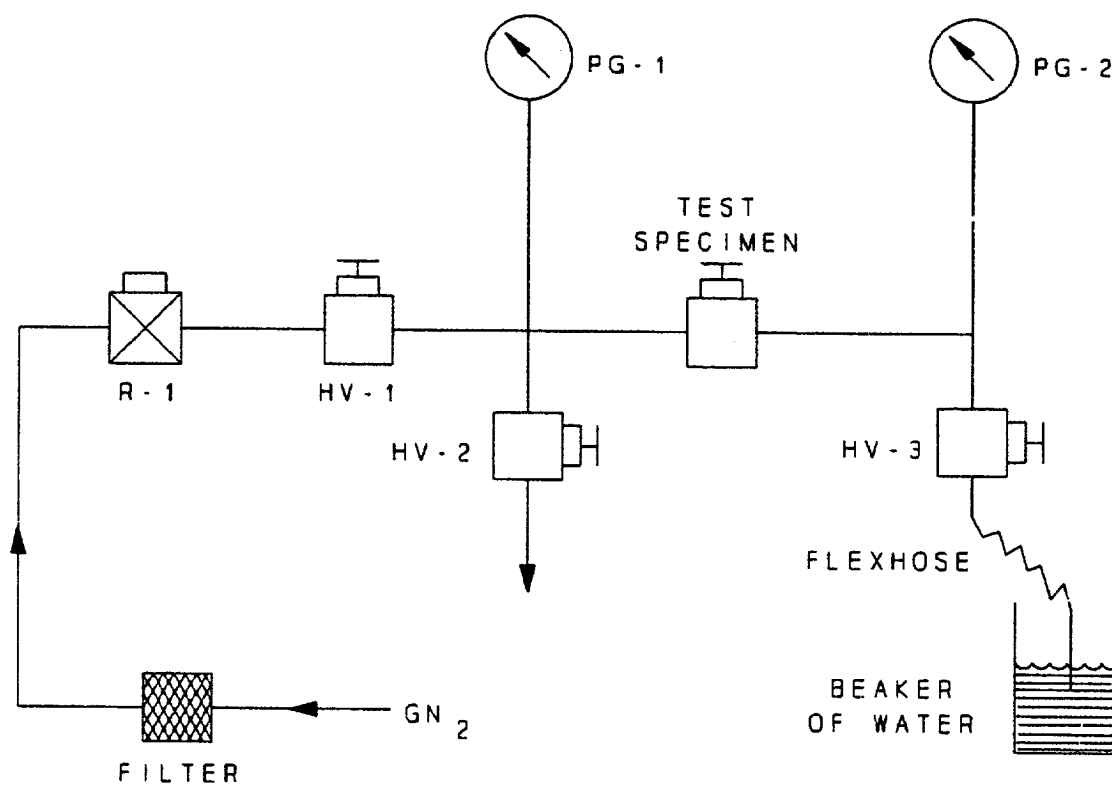

FIGURE 4  
SCHEMATIC FOR FUNCTIONAL TEST - HAND VALVE



PG - GAGE  
HV - HAND VALVE  
R - REGULATOR



FIGURE 5  
SCHEMATIC FOR FUNCTIONAL TEST - REGULATOR

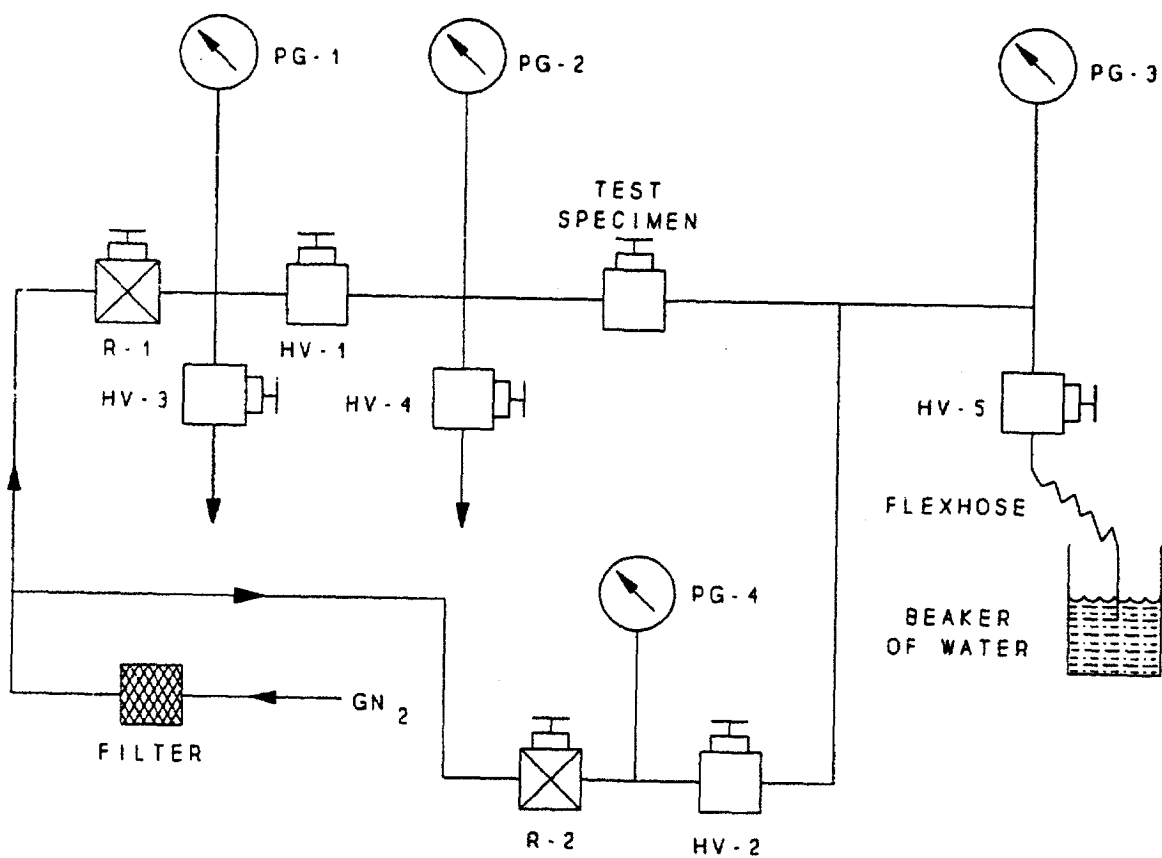

PG - GAGE  
HV - HAND VALVE  
R - REGULATOR

FIGURE 6

SCHEMATIC FOR FUNCTIONAL TEST - DOME LOADED  
REGULATOR

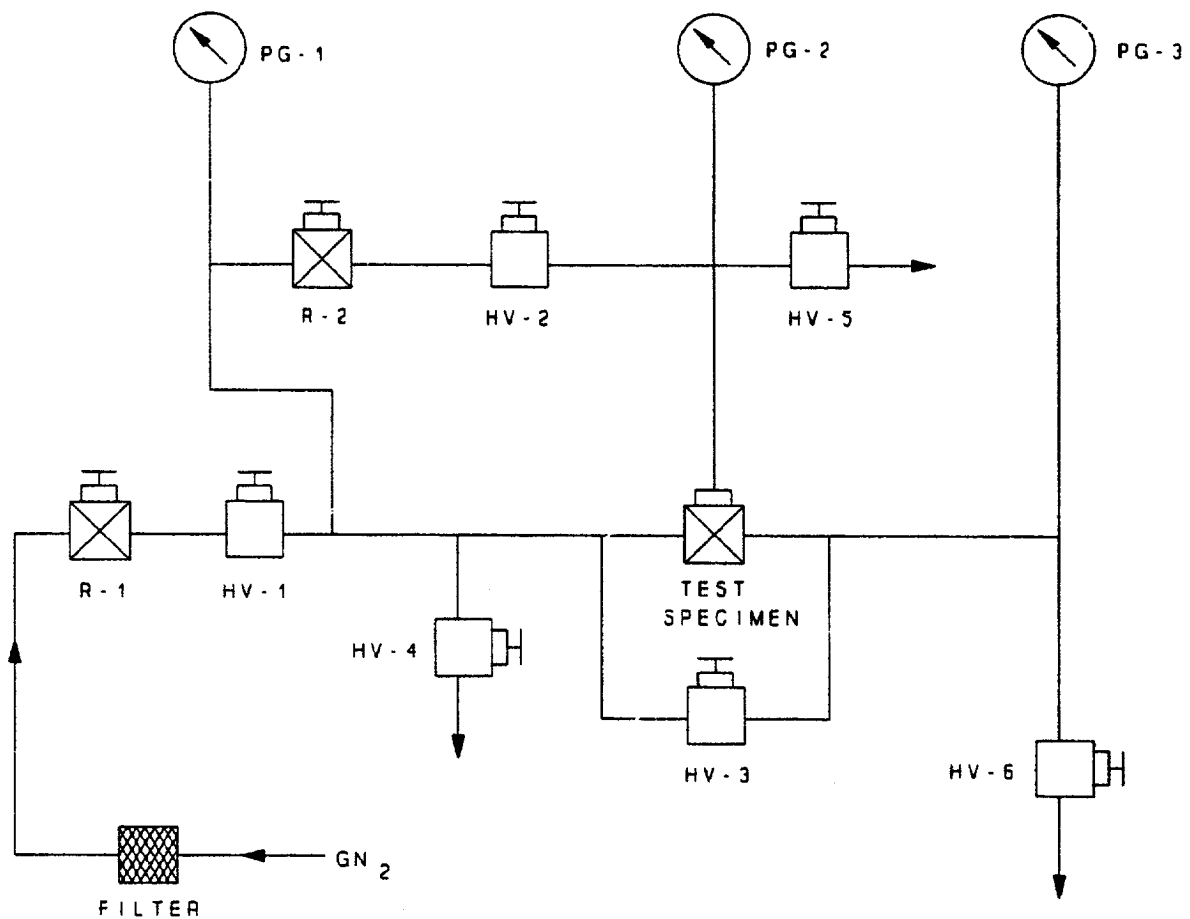

PG - GAGE  
HV - HAND VALVE  
R - REGULATOR

FIGURE 7  
SCHEMATIC FOR FUNCTIONAL TEST - RELIEF VALVE  
AND CHECK VALVES

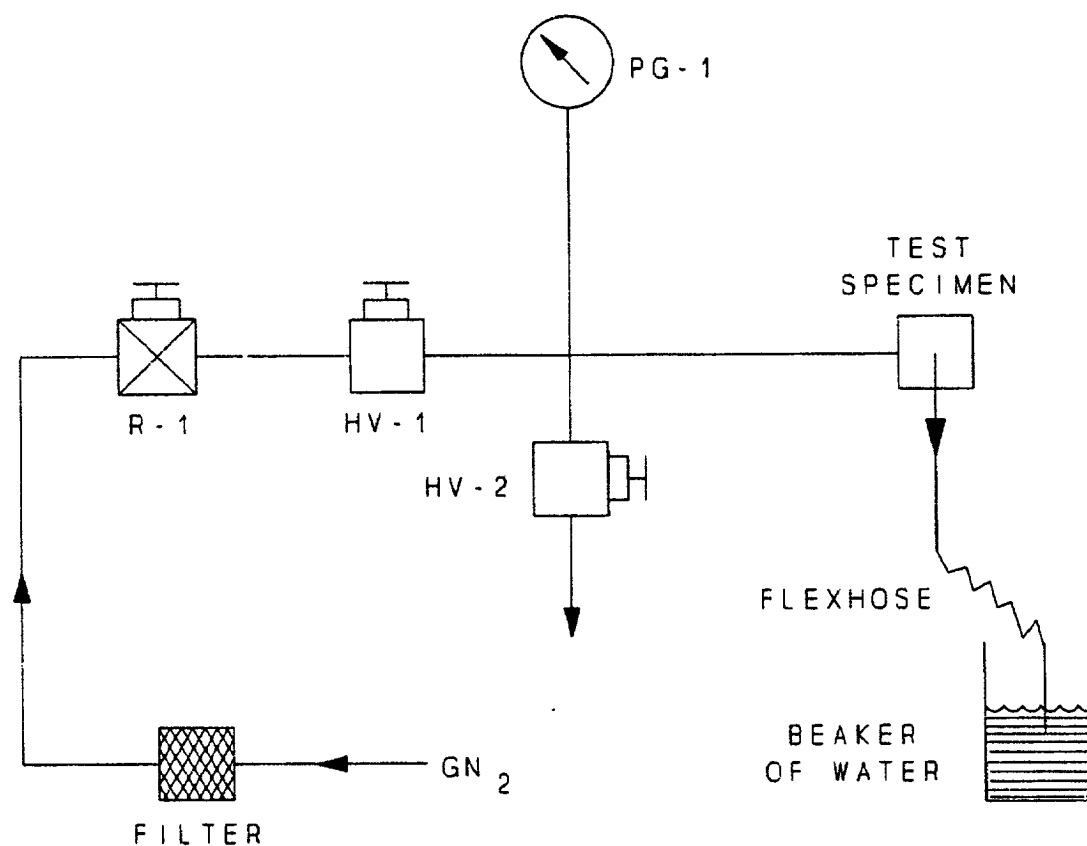

PG - GAGE  
HV - HAND VALVE  
R - REGULATOR

FIGURE 8

SCHEMATIC FOR FUNCTIONAL TEST - PRESSURE GAGE

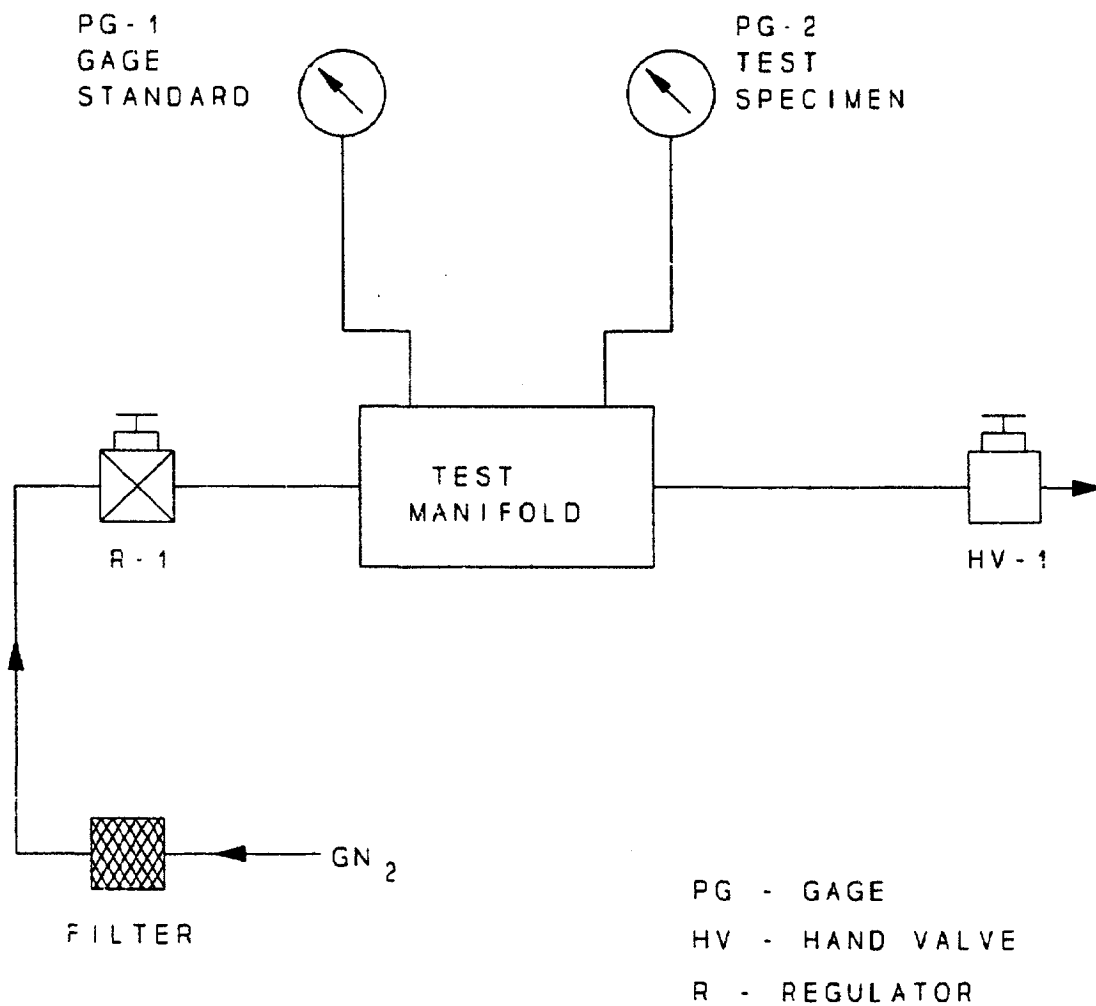

**FIGURE 9**  
**CHECKSHEET OF COMPLETED ITEMS**  
(PAGE 1 OF 3)

**KSC-SO-S-9**  
**REV. J**

DELIVERY ORDER NO. \_\_\_\_\_

TRAILER/MSU NO. \_\_\_\_\_

CONTRACT NO. \_\_\_\_\_

TYPE \_\_\_\_\_

DESCRIPTION	REFERENCE PARAGRAPH	DATE	SUBCONTRACTOR	CONTRACTOR
<u>GENERAL</u>	3.0			
INSPECTION - CONTRACTOR SITE, FIGURE 10	3.1.1			
DOCUMENTATION, FIGURES 9 - 21	3.8			
<u>DISASSEMBLY OF TRAILER/MSU</u>	4.0			
DOCUMENTATION OF MANIFOLD ASSEMBLY CONFIGURATION	4.1			
MANIFOLD ASSEMBLIES IDENTIFIED/REMOVED	4.1			
CYLINDERS PRESSURIZED	4.1			
CYLINDERS REMOVED, FIGURE 11	4.2			
EQUIPMENT PROTECTED	4.3			
<u>REASSEMBLY OF TRAILER/MSU</u>	5.0			
CONFIGURATION MAINTAINED FIGURE 11	5.1 & 5.5			
DAMAGED SURFACES	5.2			
MOUNTING SPACERS (REPLACED)	5.3			
SEALING, FIGURE 24	45.4			
<u>REHABILITATION, INSPECTION AND LUBRICATION OF TRAILER/CHASSIS</u>	6.0			
GROUNDING REEL	6.2.1			
FASTENERS & NONMETALLIC GOODS	6.2.2			
INSPECTION, FIGURE 13-A & 13-B	6.3			
LUBRICATION	6.4			
REJECTED ITEMS, FIGURE 18	6.1			

SUBCONTRACTOR SIGNATURE SIGNIFIES COMPLIANCE WITH LISTED SECTION(S).

**FIGURE 9**  
(PAGE 2 OF 3)

DESCRIPTION	REFERENCE PARAGRAPH	DATE	SUBCONTRACTOR	CONTRACTOR
CYLINDER/CHASSIS REFURBISHMENT TRAILER/MSU REPAIR REPAIR ITEMS _____	7.0 7.2			
COMPLETE REFURBISHMENT OF CARBON STEEL SURFACES ALUMINUM SURFACES REFURBISHED ITEMS: _____	A5.0 A6.0			
INORGANIC ZINC PRIMER COATING MANUFACTURER _____ COATING NAME _____	A5.3 A3.1			
INTERMEDIATE COAT MANUFACTURER _____ COATING NAME _____	A5.4 A3.1			
FINISH COAT MANUFACTURER _____ COATING NAME _____	A5.5 A3.1			
TOUCH-UP REFURBISHMENT OF SURFACES (CARBON STEEL & ALUMINUM) LOCATION: _____ MANUFACTURER _____ COATING NAME _____	A7.0 A3.1			
TOUCH-UP REFURBISHMENT OF FINISH COAT LOCATION: _____ MANUFACTURER _____ COATING NAME _____	A8.0 A3.1			
REFURBISHMENT OF VINYL FINISH COAT WITH APPLICATION OF POLYURETHANE FINISH COAT LOCATION: _____ MANUFACTURER _____ COATING NAME _____	A9.0 A3.1			

SUBCONTRACTOR SIGNATURE SIGNIFIES COMPLIANCE WITH LISTED SECTION(S).

**FIGURE 9**  
(PAGE 3 OF 3)

**KSC-SO-S-9**  
REV. J

DESCRIPTION	REFERENCE PARAGRAPH	DATE	SUBCONTRACTOR	CONTRACTOR
SPOT REPAIR WITH COMPLETE FINISH COAT LOCATION: _____	A10.0			
MANUFACTURER _____ COATING NAME _____	A3.1			
<u>CYLINDER INSPECTION, FIGURE 14</u>	8.0			
<u>CYLINDER HYDROSTATIC TEST, FIGURE 15</u>	B1.1			
<u>CYLINDER STAMPING</u> DATE STAMPED _____	B3.0			
<u>CYLINDER CLEANING</u> METHOD NO. _____	10.0			
PRE-CLEANING SAMPLES, FIGURE 12	10.2.2 14.1 14.2			
CLEANING RESULTS, FIGURE 16	14.1 14.2			
<u>TESTING OF MANIFOLD ASSEMBLY</u> HYDROSTATIC TEST, FIGURE 17	11.0 11.1			
FUNCTIONAL TEST, FIGURE 17	11.2			
LEAK TEST, FIGURE 17	11.3			
<u>REHABILITATION OF MANIFOLD ASSEMBLY</u> RESULTS ON FIGURE 17	12.0			
<u>CLEANING OF MANIFOLD ASSEMBLY</u> RESULTS ON FIGURE 16	13.0			

SUBCONTRACTOR SIGNATURE SIGNIFIES COMPLIANCE WITH LISTED SECTION(S).

**FIGURE 10  
RECEIVING INSPECTION OF TRAILER/MSU**

**KSC-SO-S-9  
REV. J**

DELIVERY ORDER NO. \_\_\_\_\_

CONTRACT NO. \_\_\_\_\_

TRAILER/MSU NO. \_\_\_\_\_

ITEMS INSPECTED	DATE	INSPECTION AT KSC		INSPECTION AT SUBCONTRACTOR'S SITE	
		CONTR.	QUAL	CONTR.	SUBCONTR.
T TIRES: CONDITION _____ PRESSURE _____					
T LIGHTS: TURN _____ RUN _____ BRAKE _____ OTHER _____					
T RUNNING GEAR					
T LANDING GEAR					
T HOOK-UP EQUIPMENT					
T TRAILER CONDITION; LICENSE					
T/M CYLINDER PRESSURIZED TO 25 +0, -10 PSIG GN <sub>2</sub> , GHe, OR BAIR ★					
T/M FORM DD 1149 SIGNED					
M CONTROL PANELS					
T/M CYLINDERS AND MANIFOLD ASSEMBLY					
T/M CYLINDER SUPPORTS/BULKHEADS					
T/M DAMAGE IN TRANSIT					

★ A STAMP IN THIS BLOCK SIGNIFIES TRAILER/MSU CONTENTS ARE INERT AND WITHIN LISTED PRESSURE RANGE.  
A CHECK MARK OR A STAMP WITHOUT ANY REMARKS SIGNIFIES THE CONDITION IS ACCEPTABLE.

T = ITEM APPLIES TO TRAILERS  
M = ITEM APPLIES TO MSUs

REMARKS:  
\_\_\_\_\_  
\_\_\_\_\_  
\_\_\_\_\_  
\_\_\_\_\_  
\_\_\_\_\_



**FIGURE 11  
CYLINDER LOCATION CHART**

**KSC-SO-S-9  
REV. J**

DATE \_\_\_\_\_

TRAILER/MSU NO. \_\_\_\_\_

DELIVERY ORDER NO. \_\_\_\_\_

TRAILER TYPE \_\_\_\_\_

CONTRACT NO. \_\_\_\_\_

SERVICE \_\_\_\_\_

DISASSEMBLY				REASSEMBLY			
POS.	SERIAL NO.	POS.	SERIAL NO.	POS.	SERIAL NO.	POS.	SERIAL NO.
1		20		1		20	
2		21		2		21	
3		22		3		22	
4		23		4		23	
5		24		5		24	
6		25		6		25	
7		26		7		26	
8		27		8		27	
9		28		9		28	
10		29		10		29	
11		30		11		30	
12		31		12		31	
13		32		13		32	
14		33		14		33	
15		34		15		34	
16		35		16		35	
17		36		17		36	
18		37		18		37	
19		38		19		38	

APPROVED:

SUBCONTRACTOR \_\_\_\_\_

CONTRACTOR \_\_\_\_\_

**FIGURE 12  
PRE-CLEANING SAMPLE ANALYSIS**

**KSC-SO-S-9  
REV. J**

DELIVERY ORDER NO. \_\_\_\_\_

TRAILER/MSU NO. \_\_\_\_\_

CONTRACT NO. \_\_\_\_\_

TYPE \_\_\_\_\_

DATE \_\_\_\_\_

PARTICLE SIZE (MICRONS)	LIMIT/FT <sup>2</sup>	SERIAL NO.	SERIAL NO.	SERIAL NO.
0 - 99	UNLIMITED			
100 - 250	93			
251 - 300	3			
301 ≤	0			
NON-VOLATILE RESIDUE GRAMS/FT <sup>2</sup>	0.001			
TOTAL FILTERABLE SOLIDS GRAMS/FT <sup>2</sup>	0.001			

REMARKS: 1. CLEANING METHOD NO. 1 SHALL BE USED FOR CLEANING CYLINDERS LINED WITH EPOXY. CLEANING METHOD NO. 2 SHALL BE USED FOR ALL OTHERS.

2. IF PRESAMPLE TFS AND NVR ARE ACCEPTABLE, STEPS 10.6.1 AND 10.6.2 DO NOT NEED TO BE PERFORMED.

SUBCONTRACTOR \_\_\_\_\_

CONTRACTOR \_\_\_\_\_

**FIGURE 13-A  
INSPECTION OF TRAILER CHASSIS**

**KSC-SO-S-9  
REV. J**

CONTRACT NO. \_\_\_\_\_

DELIVERY ORDER NO. \_\_\_\_\_

TRAILER NO. \_\_\_\_\_

DATE	ITEM	ACCEPTABLE	REJECT	CORRECTIVE ACTION
	LIGHTS			
	WIRING			
	CONNECTIONS			
	SPRINGS			
	AXLES			
	WHEEL BEARINGS			
	WHEELS			
	BRAKES			
	AIR SYSTEM			
	TIRES			
	REFLECTORS			
	LANDING GEAR			
	RUNNING GEAR			
	FRAME			
	DOORS, HINGES, LATCHES			
	FIFTH WHEEL & KINGPIN			
	MOUNTING HARDWARE			
	FENDERS			
	COMPARTMENTS			

SUBCONTRACTOR'S RECOMMENDATION FOR REFURBISHMENT:

\_\_\_\_\_

\_\_\_\_\_

\_\_\_\_\_

SUBCONTRACTOR \_\_\_\_\_

CONTRACTOR \_\_\_\_\_

**FIGURE 13-B  
INSPECTION OF MSU**

**KSC-SO-S-9  
REV. J**

CONTRACT NO. \_\_\_\_\_

DELIVERY ORDER NO. \_\_\_\_\_

MSU NO. \_\_\_\_\_

DATE	ITEM	ACCEPTABLE	REJECT	CORRECTIVE ACTION
	FRONT BULKHEAD			
	DOORS & HINGES			
	PANEL			
	COMPARTMENTS			
	REAR BULKHEADS			
	CYLINDERS			

SUBCONTRACTOR'S RECOMMENDATION FOR REFURBISHMENT:  
 \_\_\_\_\_  
 \_\_\_\_\_  
 \_\_\_\_\_

SUBCONTRACTOR \_\_\_\_\_ CONTRACTOR \_\_\_\_\_



**FIGURE 15  
CYLINDER HYDROSTATIC TEST RESULTS**

**KSC-SO-S-9  
REV. J**

**DELIVERY ORDER NO.** \_\_\_\_\_

**CONTRACT NO.** \_\_\_\_\_

**TRAILER/MSU NO.** \_\_\_\_\_

DATE	SERIAL NUMBER	CYLINDER EXPANSION (CC)	PERMANENT EXPANSION (CC)	PERMANENT EXPANSION (%)	ELASTIC EXPANSION (CC)	SUBCONTRACTOR QA	CONTR.

**SUBCONTRACTOR** \_\_\_\_\_

**CONTRACTOR** \_\_\_\_\_

**FIGURE 16**  
**LABORATORY ANALYSIS OF CLEANING SAMPLES**

**KSC-SO-S-9**  
**REV. J**

DELIVERY ORDER NO. \_\_\_\_\_

CONTRACT NO. \_\_\_\_\_

TRAILER/MSU NO. \_\_\_\_\_

DATE	IDENTIFICATION	PARTICULATE POPULATION/FT <sup>2</sup>				NVR G/FT <sup>2</sup> MAX. 0.001	SUBCONTR. QA	CONTR.
		PARTICULATE SIZE [MICRONS (μ)]						
		0 - 99	100 - 250	251 - 300	301 ≤			
		MAXIMUM ALLOWABLE POPULATION/FT <sup>2</sup>						
		★	93	3	0			

REMARKS: \_\_\_\_\_

\_\_\_\_\_

\_\_\_\_\_

\_\_\_\_\_

\_\_\_\_\_

\_\_\_\_\_

★ NO LIMIT; HOWEVER, NO DISCOLORATION OF FILTER PAD IS ALLOWED

**FIGURE 17**  
**TEST RESULTS - MANIFOLD ASSEMBLY**  
(PAGE 1 OF 3)

**KSC-SO-S-9**  
**REV. J**

DELIVERY ORDER NO. \_\_\_\_\_

TRAILER/MSU NO. \_\_\_\_\_

CONTRACT NO. \_\_\_\_\_

SERVICE \_\_\_\_\_

1. TRAILER/MSU DISASSEMBLY DATE \_\_\_\_\_.
2. TRAILER/MSU REASSEMBLY (COMPLETED) DATE \_\_\_\_\_.  
 LEAK CHECKED REASSEMBLED TRAILER/MSU AT \_\_\_\_\_ PSIG.  
 GN<sub>2</sub> DEW POINT ANALYSIS \_\_\_\_\_ °F.
3. MANIFOLD ASSEMBLY PIPING AND TUBING WERE HYDROSTATICALLY TESTED AT ONE AND A HALF TIMES DESIGN PRESSURE OF CYLINDERS OR \_\_\_\_\_ PSIG.
4. HAND VALVES
  - A. VALVE NUMBERS \_\_\_\_\_ THROUGH \_\_\_\_\_ INCLUSIVE.
  - B. HYDROSTATICALLY TESTED AT ONE AND ONE HALF TIMES DESIGN PRESSURE OF CYLINDER OR \_\_\_\_\_ PSIG.
  - C. DISASSEMBLED \_\_\_\_\_.
  - D. NEW SOFT GOODS INSTALLED \_\_\_\_\_.
  - E. CLEANED \_\_\_\_\_.
  - F. NEW BURST DISCS (IF APPLICABLE) \_\_\_\_\_ PRESSURE RANGE \_\_\_\_\_ PSIG.
  - G. REASSEMBLED \_\_\_\_\_ TORQUE VALUES USED \_\_\_\_\_.
  - H. APPLIED \_\_\_\_\_ PSIG AND \_\_\_\_\_ LEAKAGE THROUGH VALVE OR AROUND BONNET. (BOTH DIRECTIONS.)
  - I. CLEANLINESS MAINTAINED.
5. REGULATOR
  - A. DISASSEMBLED \_\_\_\_\_.
  - B. NEW SOFT GOODS \_\_\_\_\_.
  - C. CLEANED \_\_\_\_\_.
  - D. REASSEMBLED \_\_\_\_\_ TORQUE VALUES USED \_\_\_\_\_.
  - E. INLET PRESSURE \_\_\_\_\_ PSIG.
  - F. FUNCTIONAL TEST

	25%	50%	75%	100%
OUTLET PRESSURE PSIG				
RELIEF PRESSURE (IF APPLICABLE)				
RETURN TO SET				

G. CLEANLINESS MAINTAINED \_\_\_\_\_.



6. DOME REGULATOR

- A. DISASSEMBLED \_\_\_\_\_.
- B. NEW SOFT GOODS \_\_\_\_\_.
- C. CLEANED \_\_\_\_\_.
- D. REASSEMBLED \_\_\_\_\_ TORQUE VALUES USED \_\_\_\_\_.
- E. INLET PRESSURE \_\_\_\_\_ PSIG.
- F. FUNCTIONAL TEST

	25%	50%	75%	100%
DOMESTIC PRESSURE PSIG				
OUTLET PRESSURE (IF APPLICABLE)				
RETURN TO SET				

- G. CLEANLINESS MAINTAINED \_\_\_\_\_.

7. RELIEF VALVE

- A. RELIEF VALVE NOS. \_\_\_\_\_ THROUGH \_\_\_\_\_; NO. \_\_\_\_\_ AND NO. \_\_\_\_\_.
- B. DISASSEMBLED \_\_\_\_\_.
- C. NEW SOFT GOODS \_\_\_\_\_.
- D. CLEANED \_\_\_\_\_.
- E. REASSEMBLED \_\_\_\_\_ TORQUE VALUES USED \_\_\_\_\_.
- F. SET PRESSURE \_\_\_\_\_ PSIG <sup>max</sup>/<sub>min</sub> \_\_\_\_\_ PSIG <sup>max</sup>/<sub>min</sub> \_\_\_\_\_ PSIG <sup>max</sup>/<sub>min</sub>.
- G. RESEAT PRESSURE \_\_\_\_\_ PSIG <sup>max</sup>/<sub>min</sub> \_\_\_\_\_ PSIG <sup>max</sup>/<sub>min</sub> \_\_\_\_\_ PSIG <sup>max</sup>/<sub>min</sub>.
- H. CLEANLINESS MAINTAINED \_\_\_\_\_.

8. OUTLET CHECK VALVE

- A. RELIEF VALVE NOS. \_\_\_\_\_.
- B. DISASSEMBLED \_\_\_\_\_.
- C. NEW SOFT GOODS \_\_\_\_\_.
- D. CLEANED \_\_\_\_\_.
- E. REASSEMBLED \_\_\_\_\_ TORQUE VALUES USED \_\_\_\_\_.
- F. SET PRESSURE \_\_\_\_\_ PSIG <sup>max</sup>/<sub>min</sub>.
- G. RESEAT PRESSURE \_\_\_\_\_ PSIG <sup>max</sup>/<sub>min</sub>.
- H. CLEANLINESS MAINTAINED \_\_\_\_\_.

9. INLET CHECK VALVE

- A. CHECK VALVE NO. \_\_\_\_\_
- B. DISASSEMBLED \_\_\_\_\_
- C. NEW SOFT GOODS \_\_\_\_\_
- D. CLEANED \_\_\_\_\_
- E. REASSEMBLED \_\_\_\_\_ TORQUE VALUES USED \_\_\_\_\_
- F. SET PRESSURE \_\_\_\_\_ PSIG <sup>max</sup>/<sub>min</sub>
- G. RESEAT PRESSURE \_\_\_\_\_ PSIG <sup>max</sup>/<sub>min</sub>
- H. CLEANLINESS MAINTAINED \_\_\_\_\_

10. GAGES

		<u>GAGE NO.</u>	<u>GAGE NO.</u>
A. CLEANED	_____	_____	_____
B. REPAIRED	_____	_____	_____
C. FUNCTIONAL TEST:	TEST PRESSURE		
	0/0% OR _____ PSIG	_____	_____
	25/25% OR _____ PSIG	_____	_____
	50/50% OR _____ PSIG	_____	_____
	75/75% OR _____ PSIG	_____	_____
	100/100% OR _____ PSIG	_____	_____

11. NEW MANIFOLD ASSEMBLY BURST DISCS INSTALLED \_\_\_\_\_ PRESSURE RANGE \_\_\_\_\_ PSIG.

12. CLEANING RESULTS ARE ON FORM 16 \_\_\_\_\_

SUBCONTRACTOR \_\_\_\_\_

CONTRACTOR \_\_\_\_\_

**FIGURE 18  
REQUEST FOR INFORMATION (RFI)/FIELD CHANGE NOTICE**

**KSC-SO-S-9  
REV. J**

PROJECT		DATE
SUBCONTRACTOR	SUBCONTRACT NO.	RFI NO.
<b>COMPRESSED GAS TRAILERS/MSUs ARE UNDER CONFIGURATIONAL CONTROL. CHANGES IN CONFIGURED PORTIONS OF THE TRAILER/MSU MUST BE DOCUMENTED.</b>		
DISCREPANCY: (INCLUDE SPECIFICATION SECTION, IF APPLICABLE)		
SUBMITTED BY:	CONCURRENCE (SUBCONTRACT SUPERINTENDENT):	ANSWER REQUIRED BY:
PROPOSED DISPOSITION:		
NAME OF NASA SI-PEC-2 ENGINEER NOTIFIED	DATE	CONFIGURATION MANAGEMENT NOTIFIED BY BOC SUSTAINING ENG. <input type="checkbox"/> YES <input type="checkbox"/> NO
DESIGN ENGINEERING CONCURRENCE	DRAWING UPDATE REQUIRED <input type="checkbox"/> YES <input type="checkbox"/> NO	DRAWING NO.      DATE
OPERATIONS ENGINEER CONCURRENCE	DATE	SUBCONTRACT CHANGE REQUIRED <input type="checkbox"/> YES <input type="checkbox"/> NO APPROVAL (SUBCONTRACT ADMINISTRATOR)
CONSTRUCTION MANAGEMENT ENGINEER	DATE	
QA CONCURRENCE	DATE	RETURN TO ORIGINATOR

**FIGURE 19  
FINAL INSPECTION OF TRAILER/MSU**

**KSC-SO-S-9  
REV. J**

DATE \_\_\_\_\_

DELIVERY ORDER NO. \_\_\_\_\_

CONTRACT NO. \_\_\_\_\_

TRAILER/MSU NO. \_\_\_\_\_

INSPECTION	SUBCONTRACTOR	CONTRACTOR
CONFIGURATION OF TRAILER/MSU VERIFIED		
CYLINDERS PRESSURIZED WITH GN <sub>2</sub>		
TRAILER/MSU FINISH COAT INSPECTION		
TRAILER/MSU SEALING (CAULKING)		
TRAILER TIRES		
TRAILER LICENSE TAG		
TRAILER LIGHTS & REFLECTORS		
TRAILER RUNNING GEAR		
TRAILER LANDING GEAR		
TRAILER BRAKES		
DATA PACKAGE COMPLETE		
INVOICED AND CERTIFIED		
REMARKS:		

**SUBCONTRACTOR SIGNATURE SIGNIFIES THAT CONDITION IS ACCEPTABLE.**

FIGURE 20  
COMPONENT/SOFTGOOD AVAILABILITY

KSC-SO-S-9  
REV. J

THIS SHEET IS PART OF THE DATA PACKAGE FOR: GT- \_\_\_\_\_  
MSU- \_\_\_\_\_

SERVICE MEDIA \_\_\_\_\_

SUBCONTRACTOR HAS BEEN PROVIDED REQUIRED DRAWINGS AND COMPONENT SPECIFICATIONS  
BOC PROPELLANTS OPERATIONS ENGINEER \_\_\_\_\_

SIGNATURE & DATE

WE HAVE RECEIVED THE REQUIRED DOCUMENTATION  
SUBCONTRACTOR MANAGER \_\_\_\_\_

SIGNATURE & DATE

THE FOLLOWING HAS BEEN INVESTIGATED AS TO THE AVAILABILITY OF SOFTGOODS AND REPLACEMENT  
COMPONENTS:

- HANDVALVES MANUFACTURER \_\_\_\_\_ DATE OF INQUIRY \_\_\_\_\_  
REPLACEMENT COMPONENT PART NUMBER \_\_\_\_\_
- REGULATORS MANUFACTURER \_\_\_\_\_ DATE OF INQUIRY \_\_\_\_\_  
REPLACEMENT COMPONENT PART NUMBER \_\_\_\_\_
- RELIEF VALVES MANUFACTURER \_\_\_\_\_ DATE OF INQUIRY \_\_\_\_\_  
REPLACEMENT COMPONENT PART NUMBER \_\_\_\_\_
- CHECK VALVES MANUFACTURER \_\_\_\_\_ DATE OF INQUIRY \_\_\_\_\_  
REPLACEMENT COMPONENT PART NUMBER \_\_\_\_\_
- FILTERS MANUFACTURER \_\_\_\_\_ DATE OF INQUIRY \_\_\_\_\_  
REPLACEMENT COMPONENT PART NUMBER \_\_\_\_\_
- BURST DISCS MANUFACTURER \_\_\_\_\_ DATE OF INQUIRY \_\_\_\_\_  
REPLACEMENT COMPONENT PART NUMBER \_\_\_\_\_

SOFTGOODS REQUIRE BATCH TESTING PER 79K09561 AND NHB 8060.1 YES  NO

BATCH TESTING HAS BEEN INITIATED (IF REQUIRED) YES  NO

SOFTGOODS HAVE BEEN ORDERED AND COMPATIBILITY IS ENSURED

SUBCONTRACTOR \_\_\_\_\_

SIGNATURE & DATE

FIGURE 21  
DATA PACKAGE COVER SHEET  
(PAGE 1 OF 2)

KSC-SO-S-9  
REV. J

GT-\_\_\_\_\_ MSU-\_\_\_\_\_

SUBCONTRACTOR \_\_\_\_\_

DATE RECEIVED \_\_\_\_\_

WE HAVE COMPLIED WITH THE REQUIREMENTS OF KSC-SO-S-9 DURING THE REFURBISHMENT OF THIS TRAILER/MSU.

SUBCONTRACTOR MANAGER \_\_\_\_\_

DATA PACKAGE HAS BEEN REVIEWED AND IT IS IN COMPLIANCE WITH THE REQUIREMENTS OF KSC-SO-S-9. THE PACKAGE IS SUITABLE FOR HISTORICAL DATA. NASA SI-PEC-2 HAS BEEN NOTIFIED THAT A DATA PACKAGE HAS BEEN RECEIVED.

BOC PROPELLANT OPERATIONS ENGINEER \_\_\_\_\_

THERE ARE NO OUTSTANDING CONFIGURATION CHANGES THAT NEED TO BE DOCUMENTED.

BOC PROPELLANT SUSTAINING ENGINEER \_\_\_\_\_

BOC CONFIGURATION MANAGEMENT \_\_\_\_\_

**FIGURE 21**  
**DATA PACKAGE COVER SHEET**  
(PAGE 2 OF 2)

**KSC-SO-S-9**  
**REV. J**

GT- \_\_\_\_\_ MSU- \_\_\_\_\_

**DATA PACKAGE CONTENTS:**

- \_\_\_\_\_ MILLIPORE FILTER PADS CONTAINING THE PRECLEANING SAMPLES.
- \_\_\_\_\_ ORIGINAL AND ONE COPY OF FORMS 9 - 21.
- \_\_\_\_\_ ORIGINAL AND TWO COPIES OF COMPLETED FORM DD-1149.
- \_\_\_\_\_ REDLINE CONFIGURATION DRAWING INDICATING ANY APPROVED CHANGES.
- \_\_\_\_\_ CHEMICAL CERTIFICATIONS FOR ALL CHEMICALS USED.
- \_\_\_\_\_ MATERIALS CERTIFICATIONS FOR MATERIALS REQUIRED TO BE BAIR OR GO<sub>2</sub> COMPATIBLE.
- \_\_\_\_\_ SURFACE PROFILE REPLICA TAPE.
- \_\_\_\_\_ DAILY INSPECTION LOG (FOR SURFACE PREPARATION & PAINTING).
- \_\_\_\_\_ WELDER CERTIFICATION.
- \_\_\_\_\_ COPY OF ANY RFI's/DCN's ISSUED DURING THE REFURBISHMENT OF THE TRAILER/MSU.
- \_\_\_\_\_ TUBE BENDING/FLARING CERTIFICATIONS.
- \_\_\_\_\_ COPY OF CONTRACTOR QUALITY ENGINEERING "Q" POINTS.
- \_\_\_\_\_ REDLINED/AS BUILT CHASSIS DRAWING (WHEN REPLACING CHASSIS)
- \_\_\_\_\_ ONE COPY OF THE SOW.
- \_\_\_\_\_ ADDITIONAL DATA NOT PREVIOUSLY LISTED.

**NOTE:** PLACE A CHECK MARK IN FRONT OF ITEM TO DESIGNATE IT IS CONTAINED IN THE DATA PACKAGE.

**FIGURE 22**  
**TYPICAL STATEMENT OF WORK (SOW)**  
(PAGE 1 OF 2)

**KSC-SO-S-9**  
**REV. J**

---

**STATEMENT OF WORK FOR GT-124**  
**PREPARED By: D. W. SHINN**  
**DATE: OCTOBER 8, 1992**

**1.0 SCOPE**

The Compressed Gas Trailer shall be refurbished according to the requirements of KSC-SO-S-9 and the requirements stated herein. In case of conflicts between this Statement of Work and KSC-SO-S-9, this document shall take precedence. The following documents are applicable to the refurbishment of Type I Douglas Trailers.

**2.0 APPLICABLE DOCUMENTS**

<b>KSC-SO-S-9</b>	<b>Retest and Refurbishment of Compressed Gas Trailers, Standard for</b>
<b>81K01026</b>	<b>Compressed Gas Trailer, Douglas, 2460 psi, Configuration Drawing</b>
<b>79K80170</b>	<b>Gage, Pressure, Component Specification</b>
<b>81K80085</b>	<b>Valve, Globe, Component Specification</b>
<b>81K90085</b>	
<b>81K80205</b>	<b>Valve, Angle, Component Specification</b>
<b>81K90205</b>	
<b>81K80207</b>	<b>Buret Disc Assy, Component Specification</b>
<b>81K90207</b>	

The Subcontractor shall replace/repair the items listed in KSC-SO-S-9 along with the items listed in sections 3.0 and 4.0.

**3.0 REPLACEMENT ITEMS:**

**FRONT FENDERS, BOTH SIDES, REAR SECTION**

**AXLE STABILIZER BUSHINGS**

**AXLE U-BOLTS AND CAP SCREWS**

**FRONT CABINET DOOR DZUS FASTENERS**

**GAUGE HAND VALVE(S)**

**VENT HAND VALVE(S)**

**REAR CABINET DOORS, POP RIVETS IN VENT GRATING**

**REAR FENDER, CURBSIDE**

**AIR TANK BLEED VALVE WITH SPRING LOADED VALVE W/ LANYARD**

---



**FIGURE 22**  
**TYPICAL STATEMENT OF WORK (SOW)**  
(PAGE 2 OF 2)

**KSC-SO-S-9**  
**REV. J**

---

**4.0 REPAIR ITEMS:**

The following items may be replaced by the Subcontractor if it is determined to be more cost effective than repair.

FRONT CABINET BULKHEAD CURBSIDE AND STREET SIDE

REAR CABINET DOORS, STRAIGHTEN AND RE-ALIGN

REAR FENDER, STREET SIDE ANGLE SUPPORT

FRONT TIE-DOWN BRACKET, STREET SIDE, RUSTY

REMOVE - SHACKLES (TIE DOWNS)

REMOVE - DOOR TRAYS AND MISC. HARDWARE IN REAR CABINET

REMOVE - GAUGE HOLDERS IN REAR CABINET

FRONT FENDERS, STREET SIDE AND CURBSIDE

**5.0 COATING APPLICATION**

Primer to use : DIMETCOTE 6N

Tiecoat to use : AMERCOAT 71 OR AMERCOAT 185

Topcoat to use : AMERCOAT WH-1

Coat the chassis per KSC-SO-S-9 section A7.0

Coat the front cabinet per KSC-SO-S-9 section A7.0 (ALUM DOORS A10.0)

Coat the rear cabinet per KSC-SO-S-9 section A7.0 (ALUM DOORS A10.0)

Coat the cylinders per KSC-SO-S-9 section A7.0

**6.0 COMMENTS/INSTRUCTIONS FOR COATING APPLICATION**

COATING SYSTEM NOT VERIFIED

**7.0 GENERAL TRAILER REFURBISHMENT COMMENTS**

THE SUBCONTRACTOR SHALL SUBMIT AN R.F.I. REGARDING THE INSTALLATION OF A CHECK VALVE IN THE PRESSURE MANIFOLD, UPSTREAM OF THE OUTLET CONNECTION. THE CONTRACTOR SHALL RESPOND WITH A SKETCH OR CONFIGURATION DRAWING EO TO DETAIL THE MODIFICATION. THE CHECK VALVE WILL BE GFE FROM THE CONTRACTOR.

---

**FIGURE 23  
DISCREPANCY CHANGE NOTICE (DCN)**

**KSC-SO-S-9  
REV. J**

EQUIPMENT NO.	REQUESTOR (NAME)	DATE	DISC. CHG. NO.	PAGE
<b>COMPRESSED GAS TRAILERS AND MSU's ARE UNDER CONFIGURATION CONTROL. CHANGES IN CONFIGURED SYSTEMS MUST BE DOCUMENTED ON AN RFI.</b>				
DISCREPANCY:				
PROPOSED DISPOSITION:				
ROM:	LABOR \$: _____	MAT'L \$: _____	OTHER \$: _____	TOTAL \$: _____
SIGNATURE - SUBCONTRACTOR			DATE:	
ACKNOWLEDGEMENT - BOC CONTRACT TECHNICAL MANAGER			DATE:	
ACKNOWLEDGEMENT - BOC SYSTEM MAINTENANCE ENGINEER			DATE:	
ACKNOWLEDGEMENT - BOC CONTRACT ADMINISTRATOR			DATE:	

# FIGURE 24 CAULKING/SEALING DETAILS

KSC-SO-S-9  
REV. J

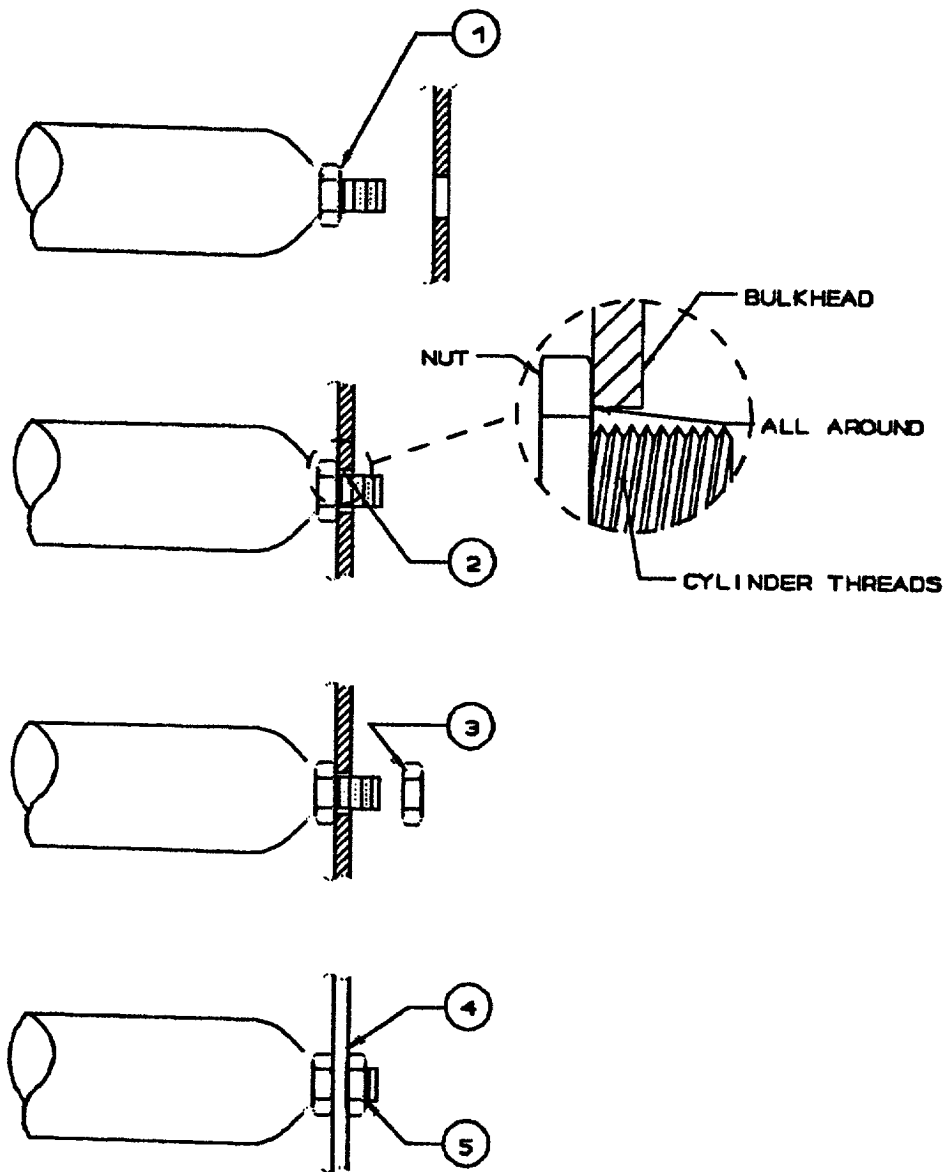

FIGURE 25

DRY FILM THICKNESS MEASUREMENT WORKSHEET																
DATE		REPORT NO.			PROJECT REF. NO.			APPLICABLE SPECIFICATION				PAGE OF				
ITEM/AREA DESCRIPTION	SPOTS	SPOT READINGS			TOTAL	AVG (+3)	% MIN	ITEM/AREA DESCRIPTION	SPOTS	SPOT READINGS			TOTAL	AVG (+3)	% MIN	
		1	2	3						1	2	3				
	A							A								
	B							B								
	C							C								
APPROX SQ. FT.	D							D								
	E							E								
SPECIFIED DFT _____ MILS							TOTAL		SPECIFIED DFT _____ MILS							TOTAL
RANGE ACHIEVED _____ MILS							AVG (+5)		RANGE ACHIEVED _____ MILS							AVG (+5)
REFERENCE REPORT DATED _____ FOR APPLICATION RECORD																
ITEM/AREA DESCRIPTION	SPOTS	SPOT READINGS			TOTAL	AVG (+3)	% MIN	ITEM/AREA DESCRIPTION	SPOTS	SPOT READINGS			TOTAL	AVG (+3)	% MIN	
		1	2	3						1	2	3				
	A							A								
	B							B								
	C							C								
APPROX SQ. FT.	D							D								
	E							E								
SPECIFIED DFT _____ MILS							TOTAL		SPECIFIED DFT _____ MILS							TOTAL
RANGE ACHIEVED _____ MILS							AVG (+5)		RANGE ACHIEVED _____ MILS							AVG (+5)
REFERENCE REPORT DATED _____ FOR APPLICATION RECORD																
ITEM/AREA DESCRIPTION	SPOTS	SPOT READINGS			TOTAL	AVG (+3)	% MIN	ITEM/AREA DESCRIPTION	SPOTS	SPOT READINGS			TOTAL	AVG (+3)	% MIN	
		1	2	3						1	2	3				
	A							A								
	B							B								
	C							C								
APPROX SQ. FT.	D							D								
	E							E								
SPECIFIED DFT _____ MILS							TOTAL		SPECIFIED DFT _____ MILS							TOTAL
RANGE ACHIEVED _____ MILS							AVG (+5)		RANGE ACHIEVED _____ MILS							AVG (+5)
REFERENCE REPORT DATED _____ FOR APPLICATION RECORD																
ITEM/AREA DESCRIPTION	SPOTS	SPOT READINGS			TOTAL	AVG (+3)	% MIN	ITEM/AREA DESCRIPTION	SPOTS	SPOT READINGS			TOTAL	AVG (+3)	% MIN	
		1	2	3						1	2	3				
	A							A								
	B							B								
	C							C								
APPROX SQ. FT.	D							D								
	E							E								
SPECIFIED DFT _____ MILS							TOTAL		SPECIFIED DFT _____ MILS							TOTAL
RANGE ACHIEVED _____ MILS							AVG (+5)		RANGE ACHIEVED _____ MILS							AVG (+5)
REFERENCE REPORT DATED _____ FOR APPLICATION RECORD																
REMARKS																
TOTAL SQUARE FOOTAGE COATED (APPROX)							INSPECTOR'S SIGNATURE _____								DATE _____	

KSC FORM 28-588 (3-91)

FIGURE 26

<b>COATING SYSTEM DAILY INSPECTION REPORT</b>																																								
DATE	REPORT NO.	PROJECT REF. NO.	PAGE OF																																					
PROJECT DESCRIPTION		LOCATION	CONTRACTOR																																					
INSPECTING ORGANIZATION		INSPECTOR	APPLICABLE SPECIFICATION NO.																																					
<b>I. DESCRIPTION OF ITEMS AND/OR AREAS</b>																																								
<b>II. DESCRIPTION OF WORK PERFORMED/REMARKS</b>																																								
<b>III. PRE-WORK SURFACE CONDITION</b>			<b>IV. ENVIRONMENTAL CONDITIONS</b>																																					
<input type="checkbox"/> SUBSTRATE _____ <input type="checkbox"/> GENERAL DESCRIPTION _____ <input type="checkbox"/> PRIMED FOR SUBSEQUENT COATS: REFERENCE REPORT DATED _____ <input type="checkbox"/> PREVIOUSLY PAINTED. DEGREE OF CORROSION _____ <input type="checkbox"/> NEW METAL. DEGREE OF CORROSION _____			<table border="1" style="width:100%; border-collapse: collapse;"> <tr> <th colspan="2" style="text-align: left; padding: 2px;">OBSERVED DEFECTS</th> <th colspan="2" style="text-align: right; padding: 2px;">CORRECTED</th> </tr> <tr> <td style="padding: 2px;">OIL &amp; GREASE</td> <td style="padding: 2px;"><input type="checkbox"/></td> <td style="padding: 2px;"><input type="checkbox"/></td> <td style="padding: 2px;"><input type="checkbox"/></td> </tr> <tr> <td style="padding: 2px;">SHARP EDGES</td> <td style="padding: 2px;"><input type="checkbox"/></td> <td style="padding: 2px;"><input type="checkbox"/></td> <td style="padding: 2px;"><input type="checkbox"/></td> </tr> <tr> <td style="padding: 2px;">WELD SPATTER</td> <td style="padding: 2px;"><input type="checkbox"/></td> <td style="padding: 2px;"><input type="checkbox"/></td> <td style="padding: 2px;"><input type="checkbox"/></td> </tr> <tr> <td style="padding: 2px;">MOISTURE</td> <td style="padding: 2px;"><input type="checkbox"/></td> <td style="padding: 2px;"><input type="checkbox"/></td> <td style="padding: 2px;"><input type="checkbox"/></td> </tr> <tr> <td style="padding: 2px;">LAMINATIONS</td> <td style="padding: 2px;"><input type="checkbox"/></td> <td style="padding: 2px;"><input type="checkbox"/></td> <td style="padding: 2px;"><input type="checkbox"/></td> </tr> <tr> <td style="padding: 2px;">SOLUBLE SALTS</td> <td style="padding: 2px;"><input type="checkbox"/></td> <td style="padding: 2px;"><input type="checkbox"/></td> <td style="padding: 2px;"><input type="checkbox"/></td> </tr> <tr> <td style="padding: 2px;">_____</td> <td style="padding: 2px;"><input type="checkbox"/></td> <td style="padding: 2px;"><input type="checkbox"/></td> <td style="padding: 2px;"><input type="checkbox"/></td> </tr> <tr> <td style="padding: 2px;">_____</td> <td style="padding: 2px;"><input type="checkbox"/></td> <td style="padding: 2px;"><input type="checkbox"/></td> <td style="padding: 2px;"><input type="checkbox"/></td> </tr> </table>		OBSERVED DEFECTS		CORRECTED		OIL & GREASE	<input type="checkbox"/>	<input type="checkbox"/>	<input type="checkbox"/>	SHARP EDGES	<input type="checkbox"/>	<input type="checkbox"/>	<input type="checkbox"/>	WELD SPATTER	<input type="checkbox"/>	<input type="checkbox"/>	<input type="checkbox"/>	MOISTURE	<input type="checkbox"/>	<input type="checkbox"/>	<input type="checkbox"/>	LAMINATIONS	<input type="checkbox"/>	<input type="checkbox"/>	<input type="checkbox"/>	SOLUBLE SALTS	<input type="checkbox"/>	<input type="checkbox"/>	<input type="checkbox"/>	_____	<input type="checkbox"/>	<input type="checkbox"/>	<input type="checkbox"/>	_____	<input type="checkbox"/>	<input type="checkbox"/>	<input type="checkbox"/>
OBSERVED DEFECTS		CORRECTED																																						
OIL & GREASE	<input type="checkbox"/>	<input type="checkbox"/>	<input type="checkbox"/>																																					
SHARP EDGES	<input type="checkbox"/>	<input type="checkbox"/>	<input type="checkbox"/>																																					
WELD SPATTER	<input type="checkbox"/>	<input type="checkbox"/>	<input type="checkbox"/>																																					
MOISTURE	<input type="checkbox"/>	<input type="checkbox"/>	<input type="checkbox"/>																																					
LAMINATIONS	<input type="checkbox"/>	<input type="checkbox"/>	<input type="checkbox"/>																																					
SOLUBLE SALTS	<input type="checkbox"/>	<input type="checkbox"/>	<input type="checkbox"/>																																					
_____	<input type="checkbox"/>	<input type="checkbox"/>	<input type="checkbox"/>																																					
_____	<input type="checkbox"/>	<input type="checkbox"/>	<input type="checkbox"/>																																					
<input type="checkbox"/> SOLVENT CLEAN _____ <input type="checkbox"/> HAND TOOL _____ <input type="checkbox"/> POWER TOOL _____ <input type="checkbox"/> HP WATER WASH _____ <input type="checkbox"/> _____ <input type="checkbox"/> _____			TIME _____ AIR TEMP °F _____ WET BULB TEMP °F _____ RELATIVE HUMIDITY %    %    %    % DEW POINT °F _____ SURFACE TEMP MIN/MAX °F / / / / WIND DIRECTION _____ WIND SPEED (MPH) _____ REMARKS _____																																					
<b>V. SURFACE PREPARATION</b>			<b>VI. PRODUCT/MIXING</b>																																					
<input type="checkbox"/> ABRASIVE BLAST _____ <input type="checkbox"/> ABRASIVE TYPE _____ <input type="checkbox"/> BLAST NOZZLE PRESSURE _____ <input type="checkbox"/> SURFACE PROFILE (AVG) _____ <input type="checkbox"/> DEGREE OF SURFACE CLEANLINESS _____ <input type="checkbox"/> COMPRESSED AIR CLEANLINESS _____			START TIME _____ STOP TIME _____ APPROXIMATE SQ. FT. PREPARED _____ REMARKS _____ PROFILE EFFECT ON TYPE <input type="checkbox"/> 1 <input type="checkbox"/> 2 GAUGE _____ MILS																																					
<table border="1" style="width:100%; border-collapse: collapse;"> <tr> <th style="width: 25%; padding: 2px;">COATING PRODUCT TYPE</th> <th style="width: 25%; padding: 2px;">MANUFACTURER</th> <th style="width: 25%; padding: 2px;">CATALOG NO./NAME</th> <th style="width: 25%; padding: 2px;">COLOR</th> </tr> <tr> <td style="padding: 2px;">COATING BATCH NUMBERS _____</td> <td style="padding: 2px;">THINNING _____</td> <td style="padding: 2px;">CAULKING _____</td> <td style="padding: 2px;">TIME MIXED _____</td> </tr> <tr> <td style="padding: 2px;">(A) _____</td> <td style="padding: 2px;">THINNER _____</td> <td style="padding: 2px;">TYPE _____</td> <td style="padding: 2px;"><input type="checkbox"/> FIRST COAT    KIT SIZE _____</td> </tr> <tr> <td style="padding: 2px;">(B) _____</td> <td style="padding: 2px;">BATCH NO. _____</td> <td style="padding: 2px;">MFG _____</td> <td style="padding: 2px;"><input type="checkbox"/> SECOND COAT    CONTAINER CONDITION _____</td> </tr> <tr> <td style="padding: 2px;">(C) _____</td> <td style="padding: 2px;">QTY ADDED _____</td> <td style="padding: 2px;">PRODUCT NO. _____</td> <td style="padding: 2px;"><input type="checkbox"/> THIRD COAT    PROPERLY STORED? _____</td> </tr> <tr> <td style="padding: 2px;">REMARKS _____</td> <td style="padding: 2px;">% BY VOLUME _____</td> <td style="padding: 2px;">BATCH NO. _____</td> <td style="padding: 2px;"><input type="checkbox"/> _____    MIXING INSTRUMENT _____</td> </tr> <tr> <td colspan="4" style="padding: 2px;">MATERIAL TEMP °F _____</td> </tr> </table>					COATING PRODUCT TYPE	MANUFACTURER	CATALOG NO./NAME	COLOR	COATING BATCH NUMBERS _____	THINNING _____	CAULKING _____	TIME MIXED _____	(A) _____	THINNER _____	TYPE _____	<input type="checkbox"/> FIRST COAT    KIT SIZE _____	(B) _____	BATCH NO. _____	MFG _____	<input type="checkbox"/> SECOND COAT    CONTAINER CONDITION _____	(C) _____	QTY ADDED _____	PRODUCT NO. _____	<input type="checkbox"/> THIRD COAT    PROPERLY STORED? _____	REMARKS _____	% BY VOLUME _____	BATCH NO. _____	<input type="checkbox"/> _____    MIXING INSTRUMENT _____	MATERIAL TEMP °F _____											
COATING PRODUCT TYPE	MANUFACTURER	CATALOG NO./NAME	COLOR																																					
COATING BATCH NUMBERS _____	THINNING _____	CAULKING _____	TIME MIXED _____																																					
(A) _____	THINNER _____	TYPE _____	<input type="checkbox"/> FIRST COAT    KIT SIZE _____																																					
(B) _____	BATCH NO. _____	MFG _____	<input type="checkbox"/> SECOND COAT    CONTAINER CONDITION _____																																					
(C) _____	QTY ADDED _____	PRODUCT NO. _____	<input type="checkbox"/> THIRD COAT    PROPERLY STORED? _____																																					
REMARKS _____	% BY VOLUME _____	BATCH NO. _____	<input type="checkbox"/> _____    MIXING INSTRUMENT _____																																					
MATERIAL TEMP °F _____																																								
<b>VII. COATING APPLICATION</b>			<b>VIII. POST CURE INSPECTION</b>																																					
METHOD OF APPLICATION _____ EQUIPMENT DESCRIPTION _____ ATOMIZING AIR CLEANLINESS _____ BRUSHED STRIPE COAT APPLIED TO HARD TO COAT AREAS? _____ START TIME _____ STOP TIME _____ APPROXIMATE SQ. FT. COATED _____ GALS COATING APPLIED _____ REMARKS _____ WET FILM THICKNESS (AVG) _____ MILS			<input type="checkbox"/> DFT WORKSHEET ATTACHED <table border="1" style="width:100%; border-collapse: collapse;"> <tr> <th style="width: 30%; padding: 2px;">SURFACE EFFECT ON GAUGE</th> <th style="width: 10%; padding: 2px;">GAUGE READING</th> <th style="width: 10%; padding: 2px;">ACTUAL</th> <th style="width: 50%; padding: 2px;">DATE VERIFIED</th> </tr> <tr> <td style="padding: 2px;">TOTAL DFT FROM PREVIOUS COATS (AVG)</td> <td style="padding: 2px;"></td> <td style="padding: 2px;">N/A</td> <td style="padding: 2px;"></td> </tr> <tr> <td style="padding: 2px;">DFT THIS COAT (AVG)</td> <td style="padding: 2px;"></td> <td style="padding: 2px;"></td> <td style="padding: 2px;"></td> </tr> </table> GENERAL APPEARANCE/REMARKS _____		SURFACE EFFECT ON GAUGE	GAUGE READING	ACTUAL	DATE VERIFIED	TOTAL DFT FROM PREVIOUS COATS (AVG)		N/A		DFT THIS COAT (AVG)																											
SURFACE EFFECT ON GAUGE	GAUGE READING	ACTUAL	DATE VERIFIED																																					
TOTAL DFT FROM PREVIOUS COATS (AVG)		N/A																																						
DFT THIS COAT (AVG)																																								
<b>IX. NON-CONFORMANCE ITEMS</b>																																								
DESCRIPTION OF DEFECT	DEFECTIVE ITEM/AREAS	SPECIFICATION REF SECTION	N.C.R. NO	DATE CORRECTED																																				
INSPECTOR'S SIGNATURE _____				DATE _____																																				



# Coating System Non-Conformance Report

Date	NCR No.	Project Ref. No.	Page _____ of _____
Project Description		Location	Contractor
Inspecting Organization		Inspector	Applicable Specification No.

<b>Related Daily Inspection Report(s) (No./Date)</b> _____ _____ _____	<b>Applicable SPEC. Sections</b> <table border="1" style="width:100%; border-collapse: collapse;"> <thead> <tr> <th style="width:33%;">Section</th> <th style="width:33%;">Page</th> <th style="width:33%;">Para</th> </tr> </thead> <tbody> <tr><td> </td><td> </td><td> </td></tr> <tr><td> </td><td> </td><td> </td></tr> <tr><td> </td><td> </td><td> </td></tr> <tr><td> </td><td> </td><td> </td></tr> </tbody> </table>	Section	Page	Para													<input type="checkbox"/> <b>Verbally Advised</b>  Name _____ ON _____ Date _____  <input type="checkbox"/> Red Tag No. _____
Section	Page	Para															

**Affected Item/Areas** \_\_\_\_\_  
 \_\_\_\_\_  
 \_\_\_\_\_

**Description of Non-Conformance** \_\_\_\_\_  
 \_\_\_\_\_  
 \_\_\_\_\_

**Remarks** \_\_\_\_\_  
 \_\_\_\_\_  
 \_\_\_\_\_

<input type="checkbox"/> <b>STOP WORK ORDER</b> You are hereby notified to STOP WORK on this project by (date) _____ unless/until the described Non-Conformance items are eliminated.	<table border="1" style="width:100%; border-collapse: collapse;"> <thead> <tr> <th style="width:50%;">Distribution</th> <th style="width:25%;">DATE DELIVERED</th> <th style="width:25%;">INITIALS</th> </tr> </thead> <tbody> <tr><td> </td><td> </td><td> </td></tr> <tr><td> </td><td> </td><td> </td></tr> </tbody> </table>	Distribution	DATE DELIVERED	INITIALS						
Distribution	DATE DELIVERED	INITIALS								
Inspector's Signature _____	Owner/Agent Authorization _____									
Inspector Signature _____										

**Corrective Action Taken** \_\_\_\_\_  
 \_\_\_\_\_  
 \_\_\_\_\_  
 \_\_\_\_\_

Date Corrective Action Initiated	Date Corrective Action Completed	Contractor Representative Signature
Related Daily Inspection Reports (No./Date)		Inspector Acceptance (Signature/Date)

FIGURE 29

# Coating System Conformance Verification Report

Date		Owner/Agent	Project Ref. No.																																																																																																																							
Project Description			Contractor																																																																																																																							
Inspecting Organization		Inspector	Applicable Specification No.																																																																																																																							
Description of Items/Area																																																																																																																										
<b>Status at Time of Final Inspection</b> <input type="checkbox"/> Shop <input type="checkbox"/> Installed <input type="checkbox"/> On-Site <input type="checkbox"/> Not-Installed <input type="checkbox"/> _____ <input type="checkbox"/> _____ Location _____		<b>Related Daily Inspection Reports</b> No. _____ Dated _____ Through _____ No. _____ Dated _____		<b>Coating Work Performed</b> <input type="checkbox"/> Does <input type="checkbox"/> Does not conform with the project coating specifications																																																																																																																						
<b>Follow-Up Required</b> <input type="checkbox"/> None <input type="checkbox"/> Touch-Up After Handling/Installation <input type="checkbox"/> Final Acceptance <input type="checkbox"/> _____ <input type="checkbox"/> _____		<b>Remarks</b>																																																																																																																								
<b>Non-Conformance Report</b> <table border="1"><thead><tr><th>NCR No.</th><th>Date Corrected</th></tr></thead><tbody><tr><td>_____</td><td>_____</td></tr><tr><td>_____</td><td>_____</td></tr><tr><td>_____</td><td>_____</td></tr><tr><td>_____</td><td>_____</td></tr><tr><td>_____</td><td>_____</td></tr><tr><td>_____</td><td>_____</td></tr><tr><td>_____</td><td>_____</td></tr><tr><td>_____</td><td>_____</td></tr><tr><td>_____</td><td>_____</td></tr><tr><td>_____</td><td>_____</td></tr><tr><td>_____</td><td>_____</td></tr><tr><td>_____</td><td>_____</td></tr><tr><td>_____</td><td>_____</td></tr><tr><td>_____</td><td>_____</td></tr><tr><td>_____</td><td>_____</td></tr><tr><td>_____</td><td>_____</td></tr><tr><td>_____</td><td>_____</td></tr><tr><td>_____</td><td>_____</td></tr><tr><td>_____</td><td>_____</td></tr><tr><td>_____</td><td>_____</td></tr><tr><td>_____</td><td>_____</td></tr><tr><td>_____</td><td>_____</td></tr></tbody></table> <input type="checkbox"/> See Att'd Continuation		NCR No.	Date Corrected	_____	_____	_____	_____	_____	_____	_____	_____	_____	_____	_____	_____	_____	_____	_____	_____	_____	_____	_____	_____	_____	_____	_____	_____	_____	_____	_____	_____	_____	_____	_____	_____	_____	_____	_____	_____	_____	_____	_____	_____	_____	_____	_____	_____	<b>Non-Conformance Items Listed on Daily Reports</b> <table border="1"><thead><tr><th>Related Daily Report No./Date</th><th>Description of Defect</th><th>Date Corrected</th></tr></thead><tbody><tr><td>_____</td><td>_____</td><td>_____</td></tr><tr><td>_____</td><td>_____</td><td>_____</td></tr><tr><td>_____</td><td>_____</td><td>_____</td></tr><tr><td>_____</td><td>_____</td><td>_____</td></tr><tr><td>_____</td><td>_____</td><td>_____</td></tr><tr><td>_____</td><td>_____</td><td>_____</td></tr><tr><td>_____</td><td>_____</td><td>_____</td></tr><tr><td>_____</td><td>_____</td><td>_____</td></tr><tr><td>_____</td><td>_____</td><td>_____</td></tr><tr><td>_____</td><td>_____</td><td>_____</td></tr><tr><td>_____</td><td>_____</td><td>_____</td></tr><tr><td>_____</td><td>_____</td><td>_____</td></tr><tr><td>_____</td><td>_____</td><td>_____</td></tr><tr><td>_____</td><td>_____</td><td>_____</td></tr><tr><td>_____</td><td>_____</td><td>_____</td></tr><tr><td>_____</td><td>_____</td><td>_____</td></tr><tr><td>_____</td><td>_____</td><td>_____</td></tr><tr><td>_____</td><td>_____</td><td>_____</td></tr><tr><td>_____</td><td>_____</td><td>_____</td></tr><tr><td>_____</td><td>_____</td><td>_____</td></tr><tr><td>_____</td><td>_____</td><td>_____</td></tr><tr><td>_____</td><td>_____</td><td>_____</td></tr><tr><td>_____</td><td>_____</td><td>_____</td></tr></tbody></table> <input type="checkbox"/> See Att'd Continuation			Related Daily Report No./Date	Description of Defect	Date Corrected	_____	_____	_____	_____	_____	_____	_____	_____	_____	_____	_____	_____	_____	_____	_____	_____	_____	_____	_____	_____	_____	_____	_____	_____	_____	_____	_____	_____	_____	_____	_____	_____	_____	_____	_____	_____	_____	_____	_____	_____	_____	_____	_____	_____	_____	_____	_____	_____	_____	_____	_____	_____	_____	_____	_____	_____	_____	_____	_____	_____	_____	_____	_____	_____	_____	_____	_____	_____	_____
NCR No.	Date Corrected																																																																																																																									
_____	_____																																																																																																																									
_____	_____																																																																																																																									
_____	_____																																																																																																																									
_____	_____																																																																																																																									
_____	_____																																																																																																																									
_____	_____																																																																																																																									
_____	_____																																																																																																																									
_____	_____																																																																																																																									
_____	_____																																																																																																																									
_____	_____																																																																																																																									
_____	_____																																																																																																																									
_____	_____																																																																																																																									
_____	_____																																																																																																																									
_____	_____																																																																																																																									
_____	_____																																																																																																																									
_____	_____																																																																																																																									
_____	_____																																																																																																																									
_____	_____																																																																																																																									
_____	_____																																																																																																																									
_____	_____																																																																																																																									
_____	_____																																																																																																																									
_____	_____																																																																																																																									
Related Daily Report No./Date	Description of Defect	Date Corrected																																																																																																																								
_____	_____	_____																																																																																																																								
_____	_____	_____																																																																																																																								
_____	_____	_____																																																																																																																								
_____	_____	_____																																																																																																																								
_____	_____	_____																																																																																																																								
_____	_____	_____																																																																																																																								
_____	_____	_____																																																																																																																								
_____	_____	_____																																																																																																																								
_____	_____	_____																																																																																																																								
_____	_____	_____																																																																																																																								
_____	_____	_____																																																																																																																								
_____	_____	_____																																																																																																																								
_____	_____	_____																																																																																																																								
_____	_____	_____																																																																																																																								
_____	_____	_____																																																																																																																								
_____	_____	_____																																																																																																																								
_____	_____	_____																																																																																																																								
_____	_____	_____																																																																																																																								
_____	_____	_____																																																																																																																								
_____	_____	_____																																																																																																																								
_____	_____	_____																																																																																																																								
_____	_____	_____																																																																																																																								
_____	_____	_____																																																																																																																								
Inspector Acceptance (Signature/Date)		Owner/Agent Concurrence																																																																																																																								

KSC F (Rev. 28-6-78) (4-93)



**24.0 APPENDIX H: WORK FLOW DIAGRAM**

# TRAILER/MSU PROCCSSING FLOWCHART

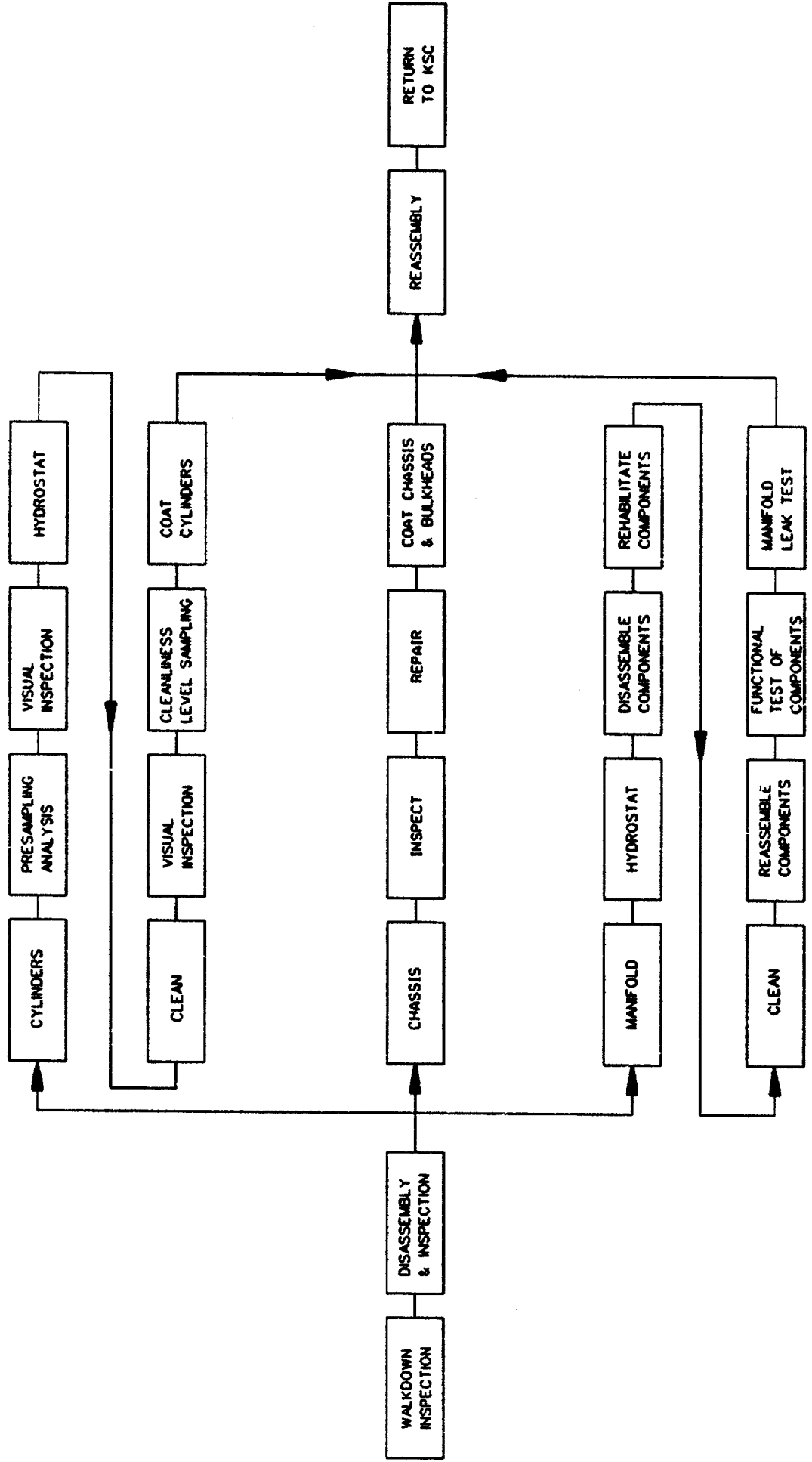

**25.0 APPENDIX J: MISCELLANEOUS DOCUMENTS**

SHIPPING CONTAINER TALLY → 1 2 3 4 5 6 7 8 9 10 11 12 13 14 15 16 17 18 19 20 21 22 23 24 25 26 27 28 29 30 31 32 33 34 35 36 37 38 39 40

REQUISITION AND INVOICE / SHIPPING DOCUMENT

1. FROM: (Include ZIP Code)  
**Equipped By: G&G Florida, Inc.  
 Kennedy Space Center, Fl. 32899**

2. TO: (Include ZIP Code)  
**503 Canaveral Center  
 Shreveport, La. 71299**

3. SHIP TO - MAKE FOR  
**Attn: Bob Amos  
 636-1083**

4. APPROPRIATION SYMBOL AND SUB-HEAD  
**W22657**

5. AUTHORITY OR APPROVAL  
**Approve 5/17/89**

6. REQUISITION DATE  
**5/09/89**

7. DATE MATERIAL REQUIRED

8. PRIORITY

9. VOUCHER NUMBER & DATE  
**89E-1017**

10. SIGNATURE  
**R. Glassey, Property**

11. DATE SHIPPED  
**6/1/89**

12. MODE OF SHIPMENT  
**Vendor Pick-up**

13. BILL OF LADING NUMBER  
**59/408**

14. AIR MOVEMENT DESIGNATOR OR PORT REFERENCE NO.

ITEM NO.	FEDERAL STOCK NUMBER, DESCRIPTION, AND CODING OF MATERIAL AND/OR SERVICES	OBJECT CLASS	EXPENDITURE ACCOUNT (To)	CHARGEABLE ACTIVITY	BUREAU CONTROL ACTIVITY NO.	BUREAU CONTROL NO.	AMOUNT	QUANTITY REQUESTED	UNIT OF ISSUE	SUPPLY ACTION	TYPE COM-TAINER MARK	COM-TAINER MARK	UNIT PRICE	TOTAL COST
1	Compressed Gas Trailer GT-102, Model #N61, S/N 000308, Tag #612550. .....LAST ITEM..... Material Located at Propellants Maint. North Bldg. K7-516, Joe Hammond will contact PEC when unit is ready. CC: P. Budzickiewicz BOC-162 D. Bogle BOC-157 B.L. Dyer BOC-110 W. Sanders BOC-338							1	TR	I				35,000.00

16. TRANSPORTATION VIA MATS OR MATS CHARGEABLE TO

17. SPECIAL HANDLING

ISSUED BY	TOTAL COM-TAINERS	DESCRIPTION	TOTAL WEIGHT	TOTAL CUMULATIVE	DATE	BY	SHEET TOTAL
CHECKED BY							GRAND TOTAL
PACKED BY							RECEIVER'S VOUCHER NO
← TOTAL →							

DD Form 1149, JUN 86 51 52 53 54 55 56 57 58 59 60 61 62 63 64 65 66 67 68 69 70 71 72 73 74 75 76 77 78 79 80 81 82 83 84 85 86 87 88 89 90 91 92 93 94 95 96 97 98 99 100

Previous editions are obsolete.

PURCHASE REQUEST (SUPPLIES, EQUIPMENT OR PROPERTY TURN IN)

ORGANIZATION/SUPPLY CODE ① FE0001		FROM SI-SAT-12 ELLEN HORN 867 3493		SHIP TO ① EG&G SUPPLY WAREHOUSE, RECEIVING BUILDING M6 744		PR 5373 9376		PRIORITY ①	PAGE 1	OF 6
DELIVER TO NAME		DATE	PHONE	BLDG	ROOM	HAND RECEIPT	ACCOUNTING CODE (Fund)	REQUIRED DATE		
APPROVAL AUTH PROP/CJST		DATE	SUGGESTED SOURCES		ACE SUPPLY CO, MERRITT ISLAND, FL 305-453-1070 RADIO SHACK, COURTENAY PARKWAY, MERRITT ISLAND, FL 305-452-2345 WRIGHTLINE OFFICE SUPPLY CO, DAYTON, OHIO 513-543-2690					
APPROVAL AUTH DEPT SEC		DATE	CONTROLLED PROPERTY SIGNATURE		TECHNICAL CONTACT ORGANIZATION					
APPROVAL AUTH BR/DIV		DATE	ORGANIZATION		VERIFICATION FUNCTIONAL BLDG PHONE					
EQUIPMENT MANAGER		DATE	ORGANIZATION		RECURRING <input type="checkbox"/> NONRECURRING <input type="checkbox"/> EXPENDABLE <input type="checkbox"/> NONEXPENDABLE <input type="checkbox"/> ISSUE <input type="checkbox"/> TURN-IN <input type="checkbox"/> NEWS Screened <input type="checkbox"/>					
PROG CONT RESOURCE MGMT		DATE	ORGANIZATION		PURCHASE USE ONLY					
PROPERTY OFFICER		DATE	ORGANIZATION		UNIT COST TOTAL COST					
RELIABIL QUALITY		DATE	ORGANIZATION		UNIT COST TOTAL COST					
NATIONAL STOCK NO. (NSN)		NOMENCLATURE - PART NUMBER (PN) - DRAWING NO. ETC.		UNIT EA	REQ	ISSUE TURN IN	UNIT COST	TOTAL COST	UNIT COST	TOTAL COST
1	7020	IBM COMPUTER, PN 4122F, CONSISTING OF: 1a. SOFTWARE, PN 356 1b. MANUALS, INSTRUCTIONS 1c. PRINTER, PN 364		EA	1	3	7504.00	7504.00	7504.00	7504.00
2	7020	ITEM COMPUTER, MDL 80, PN 342, CONSISTING OF: 2a. Printer, PN 125 2b. SOFTWARE, PN 352		EA	2	3500.00	7000.00	7000.00	3690.00	3690.00
		-----LAST ITEM-----		EA	2	1845.00	3690.00	3690.00	944.00	944.00
				EA	2	472.00	944.00	944.00	21718.00	21718.00
VENDOR'S NAME, CITY & STATE		JUSTIFICATION:		CERTIFICATION OF FUNDS						
PROCUREMENT APPROVAL		ORG.		I certify that funds in the amount of \$ _____ (plus \$100 or 10%, not to exceed \$500) are available to cover items or services listed on this document						
BUYER'S SIGNATURE		ORG.		I certify that the items listed herein have been inspected						
BPA/CC NUMBER (Circle)		DELIVERY DATE		PARTIAL <input type="checkbox"/> FINAL <input type="checkbox"/>						
		BUY DATE		AUTHORIZED GOVT REP (Signature) _____ DATE _____						
				RECEIVED QUANTITIES SHOWN ABOVE						
				STOREKEEPER'S SIGNATURE _____ DATE _____						
				Received Turn-in Quantities Shown Above (Authorized Rep's Signature) _____ DATE _____ COPY _____						

PREPARATION INSTRUCTIONS FOR KSC FORM 7-49

1. Mandatory entry for the Organization Supply Code Number. 17A & 17B For Property & QA Use Only.
  2. Enter Name, Organization, and phone number of Requester. 18. Check appropriate block.
  3. NASA/Contractor-Enter Supply Warehouse, Receiving, Bldg M6-744. 19. Name, Mail Code and Phone Number.
  4. Enter PR (Purchase Requisition) number requesting supplies, equipment or Turn-In which consists of the JULIAN DATE and a number from preassigned block. If the PR number is not available:  
EG&G: Contact Materiel Control Section.  
NASA: Leave blank if no block of PR numbers are assigned.
  5. Enter the appropriate Priority Code (See NASA/BOC Priority Code Instructions, KHB 4000.1B, Part 1, Section 4, Fig 1-4-1 and BOC 83-970-02).
 

	CRITICAL	URGENT	NORMAL
	Work Stoppage	Possible Work Stoppage	
Shuttle/Cargo	02	05	12
Centaur	03	06	13
All other BOC,NASA Programs & Requirements	08	10	15
  6. Enter the Page Number of each page.
  7. Enter Requested Date.
  8. Enter Required Date.  
**NOTE: 9 THROUGH 13 IS DELIVERY POINT.**
  9. Enter Deliver To Name and Organization.
  10. Enter Date.
  11. Enter User's Phone Number.
  12. Enter User's Building Number.
  13. Enter Room Number of User.
  14. HRA Number is required for all capital and sensitive equipment.
  15. NASA: Applicable RMO or Equipment Manager will enter code.  
BOC: Job Number and Department Supply Code.
  16. Enter all required signatures in the approval blocks only.
  17. Enter known vendors, manufacturers, phone number, cities and states or Excess. (Not to be construed as a "Sole Source of Procurement.")
- 
20. Assign a number for each major item -- NOT TO EXCEED 25 items.
  21. National Stock Number (NSN) or Stock Class.
  22. Enter description and salient characteristics -- double space each line item. On the second line, enter the complete description, Mfg. model, part number and list accessories. (SEE ATTACHED EXAMPLE).  
Equipment with an acquisition cost of \$500 or more must be reported to BOC Property Management Branch, NASA Property Branch.  
Equipment is defined as an item that will not be expended, consumed or lose its identity when issued. Personally attractive items, i.e. calculators, cameras, etc. with a cost of less than \$500 must also be reported to the respective Property Management Branch.
  - NOTE: BOC PRs over \$500 must be submitted for approval to Resource Management PRIOR to processing through Cataloging (See Block 16).
  23. Unit of issue. EXAMPLE: Box (BX), Dozen (DZ), Each (EA), etc.
  24. Enter quantity required for each line item.
  25. For Logistics Use Only.
  26. Enter estimated cost for each item and accessories.
  27. Enter extended cost for each item. Below the last item, enter the grand total.
  28. Complete justification for procurement of all items is required. When a Sole Source (Noncompetitive Procurement) is requested, enter "SOLE SOURCE" followed by a complete justification and requester's signature. Priorities must also be justified.
  29. For Procurement Use Only.
  30. For Finance Use Only.
  31. For Supply Use as appropriate.

NOTE: For detailed instructions see KHB 4000.1

