

# POTTING AND MOLDING ELECTRICAL CABLE ASSEMBLY TERMINATIONS, STANDARD FOR



## EAR 99 – NO LICENSE REQUIRED

The information contained in the document is technical in content, but not technical data as defined by the ITAR or the EAR and therefore is **EAR 99 NLR; no export license required.** (General Prohibition Six (Embargo) applies to all items subject to the EAR, i.e. items on the CCL and within EAR 99 – NLR. **You may not make an export or re-export contrary to the provisions of part 746 (Embargos and Other Special Controls) of the EAR and 22 CFR part 126.1 of the ITAR.)** EDDS #8573

March 3, 2017

## ENGINEERING DIRECTORATE

National Aeronautics and  
Space Administration

John F. Kennedy Space Center





METRIC/INCH-POUND

**KSC-STD-132**  
**Revision D, Change 3**  
**March 3, 2017**

**POTTING AND MOLDING  
ELECTRICAL CABLE ASSEMBLY TERMINATIONS,  
STANDARD FOR**

Approved by:



Patrick A. Simpkins, D.B.A.  
Director, Engineering

**March 3, 2017**

**JOHN F. KENNEDY SPACE CENTER, NASA**

**RECORD OF REVISIONS/CHANGES**

<b>REV LTR</b>	<b>CHG NO.</b>	<b>DESCRIPTION</b>	<b>DATE</b>
		Basic issue.	November 22, 1965
A		General revision.	September 7, 1972
B		General revision.	March 22, 1982
C		General revision.	June 12, 1997
D		General revision.	October 24, 2008
	D-1	Updated references and information on curing. Added illustration of overall shield termination (Figure 8). Added guidance on fabricating molds (Appendix B).	February 18, 2015
	D-2	<ol style="list-style-type: none"> <li>1. Removed MSFC-SPEC-222 and KSC-SPEC-E-0029 references.</li> <li>2. Added potting compound name and source to 4.1.1.b.</li> <li>3. Added molding and potting compound name and source to 4.1.2.b.</li> <li>4. Updated information on primers in 4.1.2.c and 5.2.3.1.</li> <li>5. Updated information on storage life in 4.1.3.1.</li> <li>6. Updated information on curing in 5.4.3. and 5.5.3.1.</li> </ol>	May 8, 2015
	D-3	Updated temperature and humidity conditions in 5.1.3.	March 3, 2017

## CONTENTS

1.	SCOPE .....	1
2.	APPLICABLE DOCUMENTS .....	1
2.1	Government Specifications .....	1
2.2	Government Standards .....	2
2.3	Government Drawings .....	2
2.4	Order of Preference .....	3
3.	DEFINITIONS .....	3
4.	GENERAL REQUIREMENTS .....	4
4.1	Materials .....	4
4.1.1	Epoxy .....	4
4.1.2	Elastomeric .....	5
4.1.3	Storage Life of Materials .....	6
4.1.3.1	Compounds and Activators .....	6
4.1.3.2	Primers .....	6
4.1.3.3	Containers .....	6
4.2	Configuration and Dimensions .....	6
4.3	Equipment .....	7
4.3.1	Vacuum Chamber .....	7
4.3.2	Mixing Containers .....	7
4.3.3	Air-Pressurization Equipment .....	7
4.3.4	Brushes .....	7
4.3.5	Weighing Equipment .....	7
4.3.6	Holding Rack .....	7
4.3.7	Injection Gun .....	8
4.3.8	Cable Molds .....	8
4.3.9	Thermometer .....	8
4.3.10	Abrasive Paper .....	8
4.3.11	Metal Spatula .....	8
4.3.12	Hot Plate .....	8
4.3.13	Curing Apparatus .....	8
5.	DETAILED REQUIREMENTS .....	9
5.1	Facilities .....	9
5.1.1	Molding and Potting Area .....	9
5.1.2	Ventilating .....	9
5.1.3	Environmental Conditions .....	9
5.1.4	Cleanliness .....	9
5.1.5	Health and Safety Precautions .....	10
5.1.6	Inspection .....	11

5.1.7	Personnel.....	11
5.2	Preparation for Potting and Molding .....	12
5.2.1	Preparation of Cable Assemblies .....	12
5.2.1.1	Adhesion .....	12
5.2.1.1.1	Pretest.....	12
5.2.1.1.2	Cleaning .....	12
5.2.1.2	Potting or Molding Over Epoxy .....	13
5.2.2	Preparation of Connectors.....	13
5.2.2.1	Protection Caps .....	13
5.2.2.2	Mating Connectors.....	13
5.2.2.3	Abrading .....	13
5.2.2.4	Priming.....	13
5.2.2.5	Assembly.....	14
5.2.3	Preparation of Cable .....	15
5.2.3.1	Primer.....	15
5.2.3.2	Wicking.....	15
5.2.3.3	Preparation of Neoprene Sheath .....	15
5.2.3.4	Preparation of PVC Sheath .....	16
5.2.3.5	Preparation of CPE Sheath.....	16
5.2.4	Potting Setup.....	17
5.2.5	Mold Preparation .....	17
5.2.6	Molding Setup.....	18
5.3	Preparation of Compounds .....	19
5.3.1	Epoxy Potting Compounds .....	19
5.3.2	Preparation of Elastomeric Compounds .....	20
5.3.2.1	Liquid.....	20
5.3.2.2	Thawing of Premixed, Frozen Cartridges.....	21
5.4	Potting Instructions .....	21
5.4.1	Inspection.....	21
5.4.2	Injection .....	22
5.4.3	Curing .....	22
5.4.4	Inspection After Curing .....	23
5.4.4.1	Connectors .....	23
5.4.4.2	Potting.....	23
5.4.5	Repair.....	23
5.5	Molding Instructions.....	23
5.5.1	Inspection.....	23
5.5.2	Injection .....	24
5.5.3	Curing .....	24
5.5.3.1	Curing Schedule.....	24
5.5.3.2	Molded Assembly.....	24
5.5.4	Inspection After Curing .....	24
5.5.4.1	Inspection Test.....	24
5.5.4.2	Transparency.....	25

5.5.4.3	Adhesion .....	25
5.5.4.4	Connectors .....	25
5.6	Repair and Rework .....	26
5.6.1	Repairable Defects .....	26
5.6.2	Rework Procedure.....	26
5.6.2.1	Minor Cavity.....	26
5.6.2.2	Major Cavities.....	26
5.6.3	Inspection.....	27
5.7	Reports .....	27
6.	NOTES.....	27
6.1	Intended Use .....	27
APPENDIX A.	ILLUSTRATIONS .....	29
APPENDIX B.	GUIDELINE FOR FABRICATING MOLDS USED WITH ELASTOMERIC COMPOUNDS TO MOLD ELECTRICAL CONNECTORS AND CABLE SHEATHS .....	41

## FIGURES

Figure 1.	Definition of Potting and Molding Terms .....	30
Figure 2.	MIL-DTL-26482 Connectors (Sheet 1 of 2).....	31
Figure 3.	Shield/Shield Adapter .....	33
Figure 4.	SAE AS 50151 Connectors (Sheet 1 of 2).....	34
Figure 5.	MIL-DTL-22992 Connectors (Sheet 1 of 3).....	36
Figure 6.	Banana Plug (Configuration 1) .....	39
Figure 7.	Banana Plug (Configuration 2) .....	39
Figure 8.	360° Overall Shield Termination Using a 120E0600001 Mold Adapter .....	40
Figure 9.	Typical Pattern (also called “Billet”).....	41
Figure 10.	Typical Mold Box with Bottom Insert Resting on Top .....	42
Figure 11.	Completed Mold Halves with Completed Cable Assembly End.....	43
Figure 12.	Typical Cable Assembly Showing One End Terminated .....	43
Figure 13.	Drip Table/Rack and Tilted Mold Boxes for Releasing Entrained Air .....	48

This page intentionally left blank.



## ABBREVIATIONS, ACRONYMS, AND SYMBOLS

°C	degree Celsius
°F	degree Fahrenheit
APPROX	approximately
CL	centerline
CPE	chlorinated polyethylene
conn	connector
dim	dimension
FSCM	Federal supply code for manufacturers
ft	foot
in	inch
KSC	John F. Kennedy Space Center
m	meter
MAX	maximum
MEK	methyl-ethyl-ketone
MIL	military
MIN	minimum
mm	millimeter ( $1 \times 10^{-3}$ m)
MSDS	Material Safety Data Sheet
MSFC	George C. Marshall Space Flight Center
MTG	mounting
NASA	National Aeronautics and Space Administration
no.	number
psi	pound per square inch
PVC	polyvinyl chloride
R	radius
RECP	receptacle
REF	reference
REQD	required
RFI	radio frequency interference

KSC-STD-132  
Revision D, Change 1

SPEC	specification
STD	standard
TYP	typical



MIL-DTL-22992	Connector, Plugs and Receptacles, Electrical, Waterproof, Quick Disconnect, Heavy Duty Type, General Specification for
SAE-AMS-DTL-23053	Insulation Sleeving, Electrical, Heat Shrinkable, General Specification for
MIL-DTL-26482	Connector, Electrical (Circular, Miniature, Quick Disconnect, Environment, Resisting), Receptacle and Plugs, General Specification for
MIL-DTL-38999	Connectors, Electrical, Circular, Miniature, High Density, Quick Disconnect (Bayonet, Threaded, and Breech Coupling), Environmental, Resistant, Removable Crimp and Hermetic Solder Contacts, General Specification for

## 2.2 Government Standards

### Military

MIL-STD-171	Finishing of Metal and Wood Surfaces
-------------	--------------------------------------

## 2.3 Government Drawings

### John F. Kennedy Space Center (KSC), NASA

79K14177	Instructions for Potting and Molding Connector Assemblies
120E0600001	Adapter Connector Molding 360° Shield Termination
120E3100003	Electrical Cable Fabrication Requirements

### George C. Marshall Space Flight Center (MSFC), NASA

MSFC-SPEC-40M38277	Connectors, Electrical, Circular, Miniature High Density, Environment Resisting, Specification for
MSFC-SPEC-40M38298	Connector, Electrical, Special Miniature High Density, Circular, Environment Resisting, 200 Deg. C, Specification for
MSFC-SPEC-40M39569	Connectors, Electrical, Miniature High Density, Circular, Environment Resisting, Specification for

75M13302

Connector, Inspection, Specification

Copies of specifications, standards, drawings, and publications required by contractors in connection with the application of this procedure should be obtained from the procuring activity or as directed by the Contracting Officer.

## 2.4 Order of Preference

In the event of conflict between the documents referenced herein and the contents of this document, the contents of this document shall supersede except where otherwise noted. The applicable NASA contract or purchase/procurement order shall take precedence over the contents of this document in the event of conflicting requirements. Nothing in this document supersedes applicable laws and regulations unless a specific exemption has been obtained. The Contracting Officer or other authorized Government official shall be notified of any such conflict in documentation.

## 3. DEFINITIONS

For the purpose of this standard, the following definitions shall apply.

- a. **abrade:** to remove gloss or roughen surface using an abrasive such as sandpaper.
- b. **chlorinated polyethylene (CPE):** a rugged thermoplastic polymer with high ultraviolet (UV), chemical, tear, and ignition resistance. CPE is also an electrical insulator.
- c. **elastomeric:** adjective for a rubberlike synthetic polymer, such as silicone rubber and polyurethane.
- d. **epoxy:** a durable, corrosion-resistant resin used in coatings.
- e. **mix:** to completely blend two or more materials or compounds into one uniform homogenous mass.
- f. **molding:** a process for creating a physical form to protect a cable termination from hazards in the operating environment, as well as to provide strain relief.
- g. **neoprene:** a synthetic rubber produced by the polymerization of chloroprene; it is highly resistant to oil, heat, light, and oxidation.
- h. **polyvinyl chloride (PVC):** any of a family of polymers derived from vinyl chloride. They have many uses in various forms, as in rigid plastic pipes and filmy food wrappers.
- i. **polyethylene:** any of several thermoplastic resins made by the polymerization of ethylene; used in making translucent, lightweight, and tough plastics, fibers, etc.

- j. **potting:** a process for creating a physical form to protect a cable connector from hazards in the operating environment, to help insulate bare wire terminations in the connector from each another.
- k. **primer:** a precoating material used to facilitate adhesion of the final coat.
- l. **sheath:** a protective cable jacket.
- m. **wicking:** the action of drawing a liquid or molten material through capillary action.

#### 4. GENERAL REQUIREMENTS

##### 4.1 Materials

The following materials, substitutions, or deviations, as approved by the cognizant design activity, shall be used.

#### NOTE

If shrinkable boots are used, all solder-type or exposed connections shall be potted with epoxy, but crimp connections protected by grommets shall not be potted. Where molding with polyurethane, crimp connections protected by grommets shall not be prepotted with epoxy; and on solder or exposed connections, the prepotting may be omitted if contact dimensions and alignment conforming to 75M13302 can be maintained during molding.

##### 4.1.1 Epoxy

- a. **Mold Release:** The following, or approved equal, mold-release compounds shall be used:

<u>Material</u>	<u>Source</u>
225 Mold Release	Valspar Corporation
MS-122 Fluorocarbon	Miller Stephensen Chemical Company
Krytox AR	E. I. DuPont DeNemours and Company

- b. **Potting Materials:** The following, or approved equal, potting compound shall be used:

<u>Material</u>	<u>Source</u>
STYCAST Epoxy 2651	Emerson & Cuming

- c. **Primers:** Primers shall be of the type recommended by the manufacturer of the material.
- d. **Solvent Cleaners:** Solvents used for cleaning purposes shall conform to the requirements of ASTM D 740 and ASTM D 4080, as applicable.

#### 4.1.2 Elastomeric

- a. **Methyl-Ethyl-Ketone (MEK):** The MEK solvent cleaner shall conform to ASTM D 740.

- b. **Molding and Potting Compounds:** The following, or approved equal, potting and molding compound shall be used:

<u>Material</u>	<u>Source</u>
PR-1535 Compound	PRC-DeSoto / PPG Aerospace

- c. **Mold Release:** The following, or approved equal, mold-release compounds shall be used:

<u>Material</u>	<u>Source</u>
225 Mold Release	Valspar Corporation

- d. **Primers:** Primers, when required, shall be of the type recommended by the manufacturer of the material.

- e. **Sealant:** When required, the following repair and sealant material, or an approved acetic-acid-free equivalent, shall be used:

<u>Material</u>	<u>Source</u>
3145 RTV Adhesive/Sealant, acetic-acid-free	Dow Corning Corporation

- f. **Tape:** When required, the following tape, or an approved equivalent, shall be used to build up the dam above the connector for prepotting:

<u>Material</u>	<u>Source</u>
Tape, electrical, plastic, polytetraflouroethylene	CHR Industries

#### **4.1.3 Storage Life of Materials**

##### **4.1.3.1 Compounds and Activators**

Storage life requirements shall conform to the manufacturer's specification.

##### **4.1.3.2 Primers**

The storage life of primers may vary because of differences in composition and shall be in accordance with the individual manufacturer's recommendations.

##### **4.1.3.3 Containers**

All containers shall be labeled as to contents, before and after mixing, and shall show the shelf life expiration date.

#### **NOTE**

Expiration date of materials may be extended for 6 months when they have been stored in a reasonably controlled atmosphere. Before qualifying the material for use, however, a button must be processed from the batch and tested for transparency and Shore A hardness according to 5.4.4.2 or repeat the criteria from 5.4.4.2. The batch is qualified for immediate use if it passes this test.

#### **4.2 Configuration and Dimensions**

Unless otherwise specified in engineering drawings, recommended configurations and dimensions shall be in accordance with the illustrations of Appendix A.



### **4.3 Equipment**

The following equipment, substitutions, or deviations, as approved by the cognizant design activity, shall be used.

#### **4.3.1 Vacuum Chamber**

An evacuation system consisting of a pump and a vacuum chamber capable of evacuation to a maximum absolute pressure of 3.4 kilopascals (kPa) (0.5 pound per square inch [psi]) shall be used to minimize entrapment of air in the molding and potting materials.

#### **NOTE**

It is recommended that an integral mixer be used with the vacuum chamber to accommodate materials with a short pot life.

#### **4.3.2 Mixing Containers**

Mixing containers shall be of a nonporous material such as metal, glass, or plastic.

#### **4.3.3 Air-Pressurization Equipment**

Air-pressurization equipment shall be capable of delivering filtered air having a maximum relative humidity of 5 percent at a minimum gage pressure of 34.5 kPa (5 psi), and maximum gage pressure of 620 kPa (90 psi), with sufficient capacity and pressure control to permit operation anywhere within this range.

#### **4.3.4 Brushes**

Brushes shall have nonmetallic bristles. All brushes (new and used) must be cleaned to remove all dirt and grease from the bristle and stored in a clean container until used.

#### **4.3.5 Weighing Equipment**

Weighing equipment shall include a gram balance and a pound balance. The gram balance shall have a 250-gram weighing capacity and shall be accurate to 1.0 gram. The pound balance shall have a 30-pound weighing capacity and shall be accurate to 0.1 pound.

#### **4.3.6 Holding Rack**

A holding rack fitted with holding clamps shall be constructed to hold the cable components rigid and in proper alignment.

#### **4.3.7 Injection Gun**

A manual-, semiautomatic-, or automatic-powered injection gun, Semco Application System, Model 250-A, PN 250125, 12 ounces with handle, (or approved equal) shall be used for injecting the potting compound into the connectors. When using potting compounds specified in this standard, disposable polyethylene nozzles, plungers, and liners are required for the injection gun. The gun capacity and nozzle size shall depend on the quality and type of connectors being potted or molded. Extra care shall be taken to provide the air gun with adequate isolation between the pressurized air and compound to avoid aeration of the mixture.

#### **4.3.8 Cable Molds**

Cable molds shall be easy to assemble, impervious to temperature change, strong and solid in construction, and easy to remove after the molding material has set. Appendix B contains a Guideline for Fabricating Molds Used with Elastomeric Compounds to Mold Electrical Connectors and Cable Sheaths.

#### **4.3.9 Thermometer**

The thermometer shall be an immersion type, ThermoFisher item #110C230FW-THERM LG-20/110C ME DS, or approved equivalent capable of measuring temperatures between -18 degrees Celsius (°C) and +110 °C (0 degree Fahrenheit [°F] and 230 °F).

#### **4.3.10 Abrasive Paper**

The abrasive paper shall be sanding sheets, no. 60 grit, or an approved equivalent.

#### **4.3.11 Metal Spatula**

The spatula shall be a Dexter-Russell traditional baker's spatula, ID 1730, PN S24912, 30.48-centimeter (cm) (12-inch [in]) stainless-steel blade, wooden handle, or an approved equal.

#### **4.3.12 Hot Plate**

The hot plate shall be a Barnstead International Thermolyne type 2200, model HPA2245MQ, or approved equivalent adjustable up to 400 °C (752 °F).

#### **4.3.13 Curing Apparatus**

The molding and potting area shall be equipped with an approved curing apparatus. The curing apparatus may be an air-circulating oven, infrared equipment, heater strips, or rods. The curing apparatus shall maintain a curing temperature as recommended by the manufacturers' curing temperature requirement within  $\pm 10$  °C ( $\pm 18$  °F) and shall provide a means of preventing hot spots during the curing process.

## **5. DETAILED REQUIREMENTS**

### **5.1 Facilities**

#### **5.1.1 Molding and Potting Area**

The dimensions of an acceptable molding and potting area shall be governed by the volume of workload. The area shall be of sufficient size to permit proper processing of cables. The area shall contain sufficient equipment and supplies to prevent the need for an overlap of operations.

#### **5.1.2 Ventilating**

The molding and potting facility shall be provided with adequate ventilation equipment to exhaust inside air to the outside and introduce sufficient fresh air in the air-conditioning system (see 5.1.3) to accommodate the volume of compounds, solvents, and primers being used per hour. Force-fed, positive-pressure ventilation is necessary where vapors are generated. Pressure inside the potting and molding facility shall be maintained at a pressure 250 kPa to 500 kPa (1 in to 2 in) of water higher than the ambient pressure outside the facility. Vapors and foreign matter shall be exhausted away from, down, and to the outside to avoid inhalation by the operator. The responsible safety agency shall be consulted to determine proper ventilation in ratio to the quantity of material being used.

#### **5.1.3 Environmental Conditions**

The temperature and humidity of the molding and potting facility shall be in conformance with the materials manufacturer's specification for handling and storage. Cure times may be adjusted according to the facility's temperature and humidity. Automatic equipment shall be installed to maintain these conditions. These conditions shall be maintained throughout all areas where mixing or other handling of potting or molding materials occurs or where these materials pass after being opened or relieved of their protective packaging. Workroom lighting should provide 1,075 lux (100 foot-candles) normal, 807 lux (75 foot-candles) minimum, at 760 millimeters (mm) (30 in) above the floor.

#### **5.1.4 Cleanliness**

The potting and molding facility shall be isolated from such contaminants as dust, metallic particles, water, oil, and grease. Bench tops shall be protected from spillage by disposable coverings, and floors shall be cleaned frequently. Cleaning agents used within the facility shall be as specified in 4.1.1.d, and the cleaning process shall be as specified in 5.2.1.1.2.

### 5.1.5 Health and Safety Precautions

When carelessly handled, the chemicals used for molding and potting may cause severe physiological reactions. The chemicals involved are safe when properly handled by trained personnel and when the following precautions are carefully observed:

- a. Avoid ingestion and inhalation of vapors.
- b. Avoid contact of solvents, primers, and compounds with the skin. Special care shall be taken to prevent contact with open breaks on the skin. Skin areas that do become exposed shall be cleaned with an approved cleaner and then with a nonabrasive soap and clean water. Cleansed jars, bottles, tools, or containers shall be individually used by personnel.
- c. Eyes or mucous membrane accidentally contaminated shall be flushed with water and receive medical attention immediately.
- d. Water deluge or flushing sink and eyewash fountain are recommended in juxtaposition to operations involving toxic skin-contaminate and inhalant materials.
- e. Protective clothing shall be changed regularly and, when soiled by potting and molding materials, shall be laundered prior to reuse.
- f. No smoking or flames shall be allowed within a room where compounds, primers, and solvents are being used. NO SMOKING and NO FOOD, BEVERAGES, OR TOBACCO ALLOWED IN THIS AREA signs shall be displayed in conspicuous places. Before smoking or eating outside the facility, personnel shall thoroughly clean exposed skin areas.
- g. An emergency shower or eyewash fountain combination is recommended immediately outside the facility room.
- h. Exits should be unobstructed from any point or area. Panic hardware shall be provided inside of exit doors.
- i. Solvents, potting and molding compounds, and other flammable materials shall be stored only in ventilated metal cabinets or containers. Appropriate fire

extinguishers shall be provided at 9 meter (m) (30 foot [ft]) intervals throughout the facility.

**NOTE**

Supervisors shall conduct periodic inspections of personnel for physiological reactions such as itching rashes, blisters, cracks, defatted areas, and any dermatitis symptoms. Personnel exhibiting any physiological reaction shall be removed from contact with plastic and rubber chemicals until approved for continuance by the applicable medical office.

- j. In addition to Hazardous Commodity Training, operations personnel should review relevant Material Safety Data Sheets (MSDSs) (via the KSC internal homepage) on an as-needed basis to become familiar with chemical hazards.

**5.1.6 Inspection**

Facilities will be subjected to inspection for compliance with the requirements of this procedure by an authorized procuring-activity representative.

**5.1.7 Personnel**

Training and certification of personnel shall be as follows:

- a. The contractor shall provide operator and inspection training in the use of equipment and material employed including familiarization with the NASA specifications and procedures to be used in the work. Personnel shall be certified by their company as inspectors or operators.
- b. The contractor shall maintain appropriate training records, including the qualifying samples, for each individual trained. The contractor shall also submit an outline of a training program to the contracting officer or designee for review.
- c. The KSC quality surveillance representative or delegated representative will review the outline for compliance with item a. above and will recommend approval or disapproval to the contracting officer.
- d. The KSC quality surveillance representative or the delegated representative may require any individual to demonstrate proficiency in any area in which the representative has reason to question the quality of work being performed.

## **5.2 Preparation for Potting and Molding**

### **5.2.1 Preparation of Cable Assemblies**

Prior to potting or molding, the cable assemblies shall pass an inspection for materials, workmanship, electrical continuity, short circuits, and isolation as specified by KSC-E-165. In all cases of shielding, bonding, and grounding, the applicable specification and design requirements for electrical configuration shall govern. All potting applications shall be coordinated with and shall conform to the basic electrical requirements for both shielded and unshielded cables.

In preparation of cable assemblies, the following items shall apply, as applicable.

#### **5.2.1.1 Adhesion**

##### **5.2.1.1.1 Pretest**

Pretest (see 5.2.3 and 5.2.3.1) all conductor jacket and sheath material to assure that proper adherence with the polyurethane molding or potting compounds can be achieved.

#### **NOTE**

When any of the insulation, jacket, or sheath material will not adhere properly, neoprene heat-shrinkable tubing conforming to SAE-AMS-DTL-23053/1 may be used as a base material, upon approval of the Contracting Officer, where the polyurethane would be in contact with the jacket or sheath.

##### **5.2.1.1.2 Cleaning**

To ensure proper adhesion of the potting compound to all components of the connector, the inner body of the connector, wires, boot, and all other materials that will contact the compounds must be clean and free of any trace of grease, oil, wax, alodyne, anodizing, hardcoat, iridite, or other contaminants. Any contaminated surface shall be cleaned by using a small stiff-bristled brush and MEK, trichloroethylene, or other approved solvent.

#### **CAUTIONS**

1. Do not expose wire insulation to the cleaning solvent beyond the time required for adequate cleaning.
2. MEK shall not be stored in or used from an open container. Only containers approved by the responsible safety agency shall be used.

### **5.2.1.2 Potting or Molding Over Epoxy**

When potting or molding over epoxy, abrade, break sharp edges, clean, and prime the epoxy surface outside of the conductor bundle (see 5.2.2.3 and 5.2.2.4).

## **5.2.2 Preparation of Connectors**

### **5.2.2.1 Protection Caps**

Protection caps shall be used at all times, including shipment, except during processes requiring mating connectors.

### **5.2.2.2 Mating Connectors**

Mating connectors are recommended for use when potting or molding connectors with resilient inserts. If mating connectors are not used, the fabricator must ensure that the contacts will stay in alignment and positions conforming to 75M13302. After mating connectors, back off coupling nut sufficiently to decompress insert materials. Salvaged connectors may be used for mating if pins, sockets, or other mating parts are not damaged.

### **5.2.2.3 Abrading**

Mask or otherwise protect conductors and finish of connectors and adapters in areas not specified to be abraded during the abrasion operation. Roughen (abrade) the rear surfaces of connectors that will contact potting or molding materials, using sandpaper or other approved materials to remove slick surfaces. Carefully remove all grit from assembly. Clean all connector threads and coupling nuts with approved solvent to remove all grease, lubricants, and foreign matter. Abrade rear threads of connector and threads of metal potting-molding adapter (where used) with sandpaper or other approved material so that the smooth surface is removed. Do not abrade connector-front mating threads, mating threads of coupling nut, or any surfaces that do not contact potting or molding materials except connector-adapter interfaces. Abrade and prime flat butt surfaces of connectors, where applicable, to ensure adhesion of polyurethane. This process is required for jam-nut connectors and shall apply for similar-type connectors.

### **5.2.2.4 Priming**

On surfaces that will contact potting or molding compound, check for cleanliness, prime with primer supplied by manufacturer of the potting compound to be used, and apply primer in accordance with the manufacturer's instructions. Check rear connection threads and mating-thread areas of adapter for cleanliness; prime with thread-seize primer; and coat with thread-seize compound (Loctite® 609 or equivalent).

### 5.2.2.5 Assembly

Perform the following steps, as applicable:

- a. Where backshell adapters are used, assemble adapter to connector and tighten. Adapters that have no stops shall be tightened until stopped by the end of threads or by binding against flange or boss of connector. Adapters tightened against coupling nuts shall be backed off until coupling nuts are free. Adapters tightened against stops shall have torque applied to the values shown in 120E3100003.

In any case where binding of coupling nuts occurs, torque requirements shall be ignored and adapters shall be backed off until coupling nuts are free. After tightening and applying torque, if adapters have setscrews, tighten into rear threads of connectors. For no. 40 shell-size, heavy-duty connectors, except the new locking type, adapters shall have 4.8 mm (3/16 in) holes drilled through the adapter and the rear connector shell on opposite sides approximately midway of thread interface (Figure A-1 in Appendix A). Take care that the drill is sleeved or otherwise prevented from reaching closer than 2.4 mm (3/32 in) to contacts. Similar metal high-shear, press-fit pins shall be driven and peened so that the pins protrude no closer than 2.4 mm (3/32 in) to a wire or contact.

The driven surfaces of pins shall be flush with adapter outer surfaces. When design calls for overall shield to be connected through the connector, the resistance from the shield through the backshell to the connector shall be less than 100 milliohms.

- b. Where coupling nuts obstruct setscrews or lockpins, coupling nuts shall have one 9.5 mm (3/8 inch) hole drilled through to allow access to screws or pins. Trimming may be necessary to allow entry into a plug hull.
- c. Break exposed sharp edges.
- d. Protect all bared surfaces (setscrews, press-fit pins, holes, etc.) that will be exposed after molding in accordance with MIL-STD-171, finishes 4.10 and 7.3.3. Paint one coat of alkyd enamel. Color shall be similar to connector color.



### **5.2.3 Preparation of Cable**

Proper preparation of cable assemblies depends on the applicable molding or potting compound and primer for the sheath material to be used. To determine whether the sheath material is neoprene, polyvinyl chloride (PVC), or chlorinated polyethylene (CPE), touch a hot soldering iron to a scrap portion of the sheath material. If the sheath is PVC, it will melt and string out. If it is neoprene, the immediate area touched will crack and harden. If it is polyethylene it will melt but not string out.

#### **5.2.3.1 Primer**

There are many types and formulations of neoprene, PVC, and CPE. The use of a primer may be necessary for some of these. Primers shall be of the type recommended by the manufacturer of the material. For CPE test production samples, see 5.2.3.5.

#### **5.2.3.2 Wicking**

To prevent wicking from occurring during cable molding or potting operations using elastomeric compounds where cable jacket (sheath) material is used, seal the cable jacket (sheath) terminations with an elastomeric dielectric sealant (see 4.1.2). The seal shall be made at the jacket (sheath) termination and sealant flow shall be directed around and through all conductors. The sealant shall not exceed 6.4 mm (1/4 in) above termination into the jacket (sheath). The diameter of the seal shall not exceed the cable diameter, including the cable jacket (sheath), and the overall length shall be 19.0 mm (3/4 in) maximum. The sealant shall be processed in accordance with the manufacturer's instructions.

#### **5.2.3.3 Preparation of Neoprene Sheath**

Neoprene sheath cables shall be prepared as follows:

- a. Use MEK to remove all grease, oil, wax, and other contaminants from the area to be covered by the molding or potting compound.
- b. The sheath shall be abraded 3.2 mm (1/8 in)  $\pm$  1.5 mm (1/16 in) above the area to be covered with the molding compound. Trimming may be necessary to allow entry into some backshells.
- c. Clean the abraded area with a nonmetallic bristled brush.
- d. Wipe the abraded area with a clean cloth dampened with MEK, changing the wiping area of the cloth as it becomes soiled. Wipe the cable dry with a clean cloth or dry with a jet of clean, dry air. A disposable wiper may be used in lieu of the cloth.

- e. If a primer is required, prime the abraded sheath area with the correct primer for the approved compound. The primer shall be applied 1.5 mm (1/16 in)  $\pm$  0.8 mm (1/32 in) above the area to be covered with the molding or potting compound. Allow to dry as instructed by the manufacturer.

#### **5.2.3.4 Preparation of PVC Sheath**

PVC sheath cables shall be prepared as follows:

- a. Brush or wipe the sheath 3.2 mm (1/8 in)  $\pm$  1.5 mm (1/16 in) above the area to be covered with the molding and potting compound with uncontaminated MEK until the surface becomes tacky.
- b. If a primer is required, prime the tacky area with the correct primer for the approved compound. The primer shall be applied 1.5 mm (1/16 in)  $\pm$  0.8 mm (1/32 in) above the prepared surface to be covered with the molding and potting compound. Allow to dry as instructed by the manufacturer.

#### **5.2.3.5 Preparation of CPE Sheath**

Before potting and molding production cables, sample cables shall be made and tested as follows:

- a. Prepare sample cable assembly.
  - (1) Apply manufacturer's recommended primer according to manufacturer's instructions.
  - (2) Mold in accordance with this standard.
  - (3) After curing and when cable assembly is at room temperature, the cable shall be flexed and tested for adhesion of the molding material to the cable sheath, in accordance with this standard.
- b. If satisfactory adhesion is not obtained, prepare a second sample cable assembly.
  - (1) Apply a length of neoprene or PVC shrink tubing (SAE-AMS-DTL-23053/1 or /2) over the end of the conductor insulation and cable sheath. Tubing shall extend along the cable sheath approximately 38 mm (1 1/2 in) above the molded portion.
  - (2) Mold requirements shall be in accordance with this standard, as applicable.

- (3) After curing and when cable assembly is at room temperature, the cable shall be flexed and tested for adhesion of the molding material to the cable sheath, in accordance with this standard.
- c. Production cables shall be made using the method providing the proper adhesion.

#### 5.2.4 Potting Setup

Potting setup shall be as follows and shall meet the requirements in 120E3100003:

- a. Assemble the mating connector (see 5.2.2.2) to ensure proper contact alignment during potting. The mating connector shall remain in place until sufficient curing time has elapsed.
- b. Clamp the connector in an upright, level, and secure position to prevent any movement of the components. The wire or cable shall be clamped in a vertical position to avoid any strain on the terminal joints.
- c. The wire bundle shall be centered with respect to the connector and potting boot. Bundling shall not cause conductors to impose lateral strain on terminals. Unless otherwise specified, lateral clearance to surface of potting boot shall be 1.5 mm (1/16 in) minimum for all internal parts and end of sheath.

#### 5.2.5 Mold Preparation

Molds shall be prepared as follows and shall meet the requirements in 120E3100003:

- a. Examine and clean all surfaces and vent ports prior to each use.
- b. Using a brush, clean cloth, or aerosol spray, apply approved mold release to all surfaces of the mold and dry in an oven at  $65\text{ }^{\circ}\text{C} \pm 5\text{ }^{\circ}\text{C}$  ( $149\text{ }^{\circ}\text{F} \pm 9\text{ }^{\circ}\text{F}$ ). Do not leave marks on the cavity surfaces. Polish as necessary to obtain a blemish-free surface.

#### **CAUTION**

If electronic devices are inserted into the molding, be aware of specified high-temperature limit for the devices.

#### **NOTE**

If a mold is being used for the first time, the molding release application and drying procedure in step b. above shall be performed twice.

## 5.2.6 Molding Setup

The mold shall be assembled as follows:

### NOTE

Prior to potting or assembly into a mold, electrical connectors shall be inspected for coupling-nut binding. The coupling nut must rotate as freely as required for proper connector engagement.

- a. Examine the cable assembly and determine that preparation procedures for neoprene, PVC, or CPE, as applicable, are complete as outlined in 5.2.3.
- b. Examine the assembly for freedom from contamination and foreign particles.
- c. Unless otherwise specified, lateral clearance to the surface of the mold shall be 1.5 mm (1/16 in) minimum from all internal parts and from the end of the cable sheath.
- d. When inserting the cable sheath into the mold, the sheath should be pressed as far as possible toward the connector to afford slack in conductors. Shield rings should be checked to ascertain that they are within  $\pm 10$  degrees perpendicular to the axis of the cable.
- e. Before assembly of mold halves, all requirements of configurations and dimensions should be fully checked against Appendix A and the design drawings as specified. Where configuration and dimensional requirements are hampered, consult cognizant design activity before molding.
- f. Assemble the two half-sections of the mold around the cable assembly.
- g. Before tightening the clamping screws, examine the assembly for correct alignment and positioning of the cable and connector.
- h. Tighten the clamping screws sufficiently to prevent leakage of the compound.
- i. Clamp the assembled mold and cable in a vertical, level, and secure position with the cable connector down. The cable shall be vertically clamped above the mold to maintain alignment.
- j. The mold shall be clamped to restrict movement while compound is injected.

### 5.3 Preparation of Compounds

#### 5.3.1 Epoxy Potting Compounds

Verify that the two-part material, resin and activator shelf life has not expired. Use the following steps in preparing the compound for application:

- a. Examine the contents of both parts for solidification.
- b. If either of the parts has thickened, solidified, or crystallized, heat the part to the manufacturer's recommended temperature. When heating, a thermometer shall be used to determine the actual material temperature. Stirring is essential during heating to assure uniformity and to hasten the melting procedure. Allow both parts to cool in room-ambient temperature at 21 °C to 24 °C (70 °F to 75 °F) before mixing. Do not artificially cool the material.
- c. Place both parts (in the proper proportional ratios) in a clean, dry, nonporous container having a capacity of at least four times the volume of the combined parts. Blend the parts thoroughly by mechanical agitation or by stirring with a clean metal spatula. Avoid fast stirring that may entrap excessive air and reduce application life.
- d. Place the container in a vacuum chamber and reduce the pressure to a maximum absolute pressure of 3.4 kPa (0.5 psi). Maintain this pressure until foaming subsides, but not more than 20 minutes.
- e. Transfer the mixed compound from the mixing container to the injection-gun cartridge by carefully and slowly pouring the compound down the inside of the cartridge, using care not to entrap air, until the desired level in the cartridge is reached. Put the plastic plunger in place and insert the cartridge into the gun.

#### **NOTE**

Do not degas the compound by use of a centrifuge.

## 5.3.2 Preparation of Elastomeric Compounds

### 5.3.2.1 Liquid

The liquid compound shall be two-part units, consisting of base resin and activator, and shall be prepared as follows:

- a. Verify that the material shelf life has not expired.

#### **CAUTION**

Use premeasured kits as supplied by the manufacturer. Do not use broken or partially used kits.

- b. Examine the contents of the base resin and activator for solidification.
- c. If either of the parts has thickened, solidified, or crystallized, heat the part to the manufacturer's recommended temperature. When heating, a thermometer shall be used to determine the actual material temperature. Stirring is essential during heating to assure uniformity and to hasten the melting procedure. Allow both parts to cool in room ambient temperature at 21 °C to 24 °C (70 °F to 75 °F) before mixing. Do not artificially cool the material.
- d. Place the base resin and activator in a clean, dry nonporous container having a capacity of at least six times the volume of the combined parts. Blend the parts thoroughly by mechanical agitation or by stirring with a clean metal spatula. Avoid fast stirring that may entrap excessive air and reduce application life.
- e. Place the container in a vacuum chamber and reduce the pressure to a maximum absolute pressure of 3.4 kPa (0.5 psi). Maintain this pressure until foaming subsides, but not more than 20 minutes.

#### **NOTE**

Do not degas the compound by use of a centrifuge.

- f. Transfer the degassed compound into the injection-gun cartridge by flowing the compound down the inside of the cartridge, using care not to entrap air.
- g. Put the plastic plunger in the cartridge next to the molding and potting material. Exercise care not to entrap air while inserting the plunger.

### 5.3.2.2 Thawing of Premixed, Frozen Cartridges

It is recommended that the thawing time and temperature of the frozen cartridges be closely controlled to obtain sufficient application life. An increase in either thawing time or temperature will reduce application life, and a decrease in either thawing time or thawing temperature will result in an incomplete thaw. The results are the responsibility of the molding facility. The following steps are recommended for thawing premixed, frozen cartridges:

- a. When stored at  $-4\text{ }^{\circ}\text{C}$  to  $-7\text{ }^{\circ}\text{C}$  ( $-40\text{ }^{\circ}\text{F}$  to  $-45\text{ }^{\circ}\text{F}$ ), remove the cartridge from storage and thaw for 30 minutes  $\pm$  1 minute at  $49\text{ }^{\circ}\text{C} \pm 5\text{ }^{\circ}\text{C}$  ( $120\text{ }^{\circ}\text{F} \pm 9\text{ }^{\circ}\text{F}$ ). When stored at  $-26\text{ }^{\circ}\text{C}$  to  $-28\text{ }^{\circ}\text{C}$  ( $-78\text{ }^{\circ}\text{F}$  to  $-3\text{ }^{\circ}\text{F}$ ), remove the cartridge from storage and thaw for 40 minutes  $\pm$  1 minute at  $49\text{ }^{\circ}\text{C} \pm 5\text{ }^{\circ}\text{C}$  ( $120\text{ }^{\circ}\text{F} \pm 9\text{ }^{\circ}\text{F}$ ).

#### **NOTE**

A heating block or controlled heat lamps may be used for thawing frozen cartridges. Other thawing methods may be used upon approval by the procuring activity.

- b. During the thawing process, the cartridge shall be maintained in an upright position, nozzle-end down with cap plug in place, to prevent air from entering and becoming trapped within the compound.
- c. Completely thaw and check the plunger to make sure that no air is entrapped.
- d. When once thawed, premixed frozen cartridges shall not be refrozen. The cartridges shall not be used after application life has expired.

## 5.4 Potting Instructions

Epoxy or elastomeric compound shall be used for potting, as specified by the contracting officer. The following suggested potting techniques vary from shop to shop because of equipment, facilities, or experience of personnel.

### 5.4.1 Inspection

Examine cable assembly and determine that preparation procedures, as applicable, are complete and that assembly is free of contamination and foreign particles. Provide a small sample of the potting compound for later Shore hardness testing. The sample shall be cured in the same environment as the connector(s) being potted.

### 5.4.2 Injection

- a. Ensure that a cartridge of prepared compound is ready for use with the injection gun.
- b. When an air-powered injection gun is to be used, attach the injection gun to the air supply (see 4.3.3 and 4.3.7) using the applicable hose connection. Attach the correct-size gun nozzle suitable for the potting job and adjust air pressure for a slow, even flow of compound [approximately 69 kPa to 103 kPa (10 psi to 15 psi) (gage)].
- c. Test the injection gun for a free and even flow of compound from the nozzle.
- d. Carefully insert the nozzle tip near the bottom of the connector for flow of compound around terminals (see alternate step e., below). Set the compound flow evenly by keeping the nozzle tip at the swell level. Avoid air entrapment during the flow operation.
- e. When necessary, drill a 6.4 mm (1/4 in) access hole in the boot 6.4 mm (1/4 in) above the back edge of the connector and insert nozzle tip. Tape hole when filling is complete.
- f. If the compound rises unevenly, reposition the nozzle to allow level distribution. When repositioning the nozzle, the flow of compound should be stopped. Lifting the nozzle while the compound is flowing will cause folding and voids in the fill.
- g. Continue injection of the compound until the boot is full or predetermined level is attained. Allow the compound to settle for 5 minutes. This lets any entrapped air escape. When the compound settles, replenish to the required convex level. Do not allow the compound to enter the bonding holes on the molding adapter.
- h. Cover exposed connections with compound.
- i. If no injection gun is available, introduce the compound into the prepared connector by carefully hand-pouring the compound down one side of the connector in such a manner as to allow the compound to flow between the wires and contacts, entrapping a minimum amount of air. Fill the connector to the predetermined level, allow to set for 5 minutes, then fill to the required convex level.

### 5.4.3 Curing

Curing schedules shall be selected from those recommended by the manufacturer. Cure conditions (time and temperature) may vary based on application requirements, curing equipment, oven loading and actual oven temperatures.



## **5.4.4 Inspection After Curing**

### **5.4.4.1 Connectors**

After curing, inspect pins for length and condition according to 75M13302.

### **5.4.4.2 Potting**

The potted cable shall be inspected for hardness, general appearance, and quality of workmanship. The surfaces of the potted area shall be free from voids, blisters, tackiness, soft spots, cracks, lumps, or any defect indicative of low quality or poor workmanship. The hardness shall be determined by three readings of a Shore Instrument and Manufacturing Company durometer, or approved equivalent, using D scale for epoxy or A scale for elastomeric compound. The hardness of the cured material shall conform to the approved products list hardness rating for each applicable listed product.

### **CAUTION**

Inspection personnel shall use care in handling assemblies potted with epoxy resins. The rigid, sharp edges of the cured resins in contact with the cable sheath may cut, mar, or mutilate the sheath material if the cable is forcefully handled

## **5.4.5 Repair**

Rework or repair of individual defects shall be at the discretion of the procuring activity. Repairable or reworkable defects shall be limited to those capable of being repaired or reworked without affecting serviceability or leaving undesirable latent defects. After repair or rework, the assembly shall be inspected to determine conformance to 5.4.4.

## **5.5 Molding Instructions**

The following suggested molding techniques may vary from shop to shop because of equipment, facilities, or experience of personnel. Refer to 79K14177 for more explicit instructions.

### **5.5.1 Inspection**

Prior to molding, examine the setup and determine that preparation, in accordance with 5.2.6, has been made and is in order. Provide a small sample of the molding compound for later Shore hardness testing. The sample shall be cured in the same environment as the connector(s) being molded.

## **5.5.2 Injection**

- a. The injection gun should have a cartridge of prepared compound inserted and ready for use.
- b. Attach the injection gun to the air supply (see 4.3.7) using the applicable hose connection. Attach the correct size gun nozzle suitable for the molding job and adjust air pressure for slow, even flow of compound (approximately 69 kPa to 103 kPa [10 psi to 15 psi (gage)]).
- c. Test the injection gun for free and even flow of compound from the nozzle.
- d. Place the nozzle of the loaded cartridge into the injection port or mold, maintaining the required pressure. Force the molding compounds slowly into the mold until the compound emerges from the vent holes.
- e. Slowly withdraw the gun nozzle from the injection port and maintain the required pressure on the gun to allow the injection port to be filled with compound. Plug the injection port and allow the compound to settle in the mold.
- f. Allow 15 minutes to 20 minutes for settling, then inject additional compound into the mold until the compound is flowing from the vents. Slowly withdraw the gun nozzle from the injection port, maintaining the required pressure on the gun to allow the injection port to be filled with compound.
- g. Plug the injection port on the side of the mold.

## **5.5.3 Curing**

### **5.5.3.1 Curing Schedule**

Curing schedules shall be selected as recommended by the manufacturer. Cure conditions (time and temperature) may vary based on application requirements, curing equipment, oven loading and actual oven temperatures.

### **5.5.3.2 Molded Assembly**

The molded assembly shall be submitted for inspection only after the assembly has been fully cured and cooled to room temperature.

## **5.5.4 Inspection After Curing**

### **5.5.4.1 Inspection Test**

The molded cable shall be inspected for hardness, general appearance, and quality of workmanship. The hardness shall be determined by three readings using a Shore Instrument and

Manufacturing Company scale durometer, or an approved equal. The hardness of the cured compound shall conform to the approved products list hardness rating for each applicable listed product. The molded or potted surfaces shall be free of surface bubbles, blisters, tackiness, gas pockets, and other defects.

**NOTE**

Some rejected assemblies may be used as test fixtures or emergency spares or may otherwise be acceptable to the United States Government. Other rejected assemblies may possibly be reworked or used for mating purposes; therefore, potted or molded assemblies that have been disqualified or rejected shall not be destroyed until the cognizant design activity has been notified and discrepancies have been discussed with an inspection representative.

**5.5.4.2 Transparency**

When drawings specify clear or transparent molding, some coloration or cloudiness is allowable. Degree of transparency shall be such that after curing, shield rings, conductors, and other internal details shall be visible under ordinary light approximately 430 lux (40 foot-candles) to the unaided eye. Bubbles from trapped voids shall be permissible if not more than 3.2 mm (1/8 in) in diameter and not closer than 1.6 mm (1/16 in) to conductor terminations or mold outer surface. There shall be no more than five visible bubbles as described above, per cubic inch, in any one mold.

**5.5.4.3 Adhesion**

After full cure and after the assembly has cooled to room temperature, the cable shall be flexed five times at the tapered molded portion to determine whether the material is securely bonded to the cable. In no instance shall undue force be applied in order to determine adhesion. A blunt probe made of wood or plastic shall be used to test the adhesion of the molding or potting compound the electrical connector. Care shall be taken to avoid damage to the assembly during inspection. Separation of the material from the cable or connector shall be cause for rejection.

**5.5.4.4 Connectors**

After curing, inspect pins for length and condition according to 75M13302.

## **5.6 Repair and Rework**

### **5.6.1 Repairable Defects**

Repairable defects shall consist of those defects capable of repair without affecting serviceability or without leaving undesirable latent effects as determined by the procuring activity. After repair, the assembly shall again be inspected to determine conformance to 5.5.4.1 and 5.5.4.4.

### **5.6.2 Rework Procedure**

#### **5.6.2.1 Minor Cavity**

In situations where a minor cavity defect is present on a molded surface, the following rework procedure is permissible:

- a. Determine that the rework surface is clean.
- b. Remove contaminants by wiping with MEK.
- c. Prepare approved patch compound in accordance with the manufacturer's instructions and fill the cavity with mixed compound.
- d. Position a sheet of polyethylene film, or other proper mold, over the filled cavity and tape securely in place using heat-resistant, pressure-sensitive tape or mold-tightening screws.
- e. Cure according to the manufacturer's instructions.
- f. Remove tape and polyethylene film, or the mold.

#### **5.6.2.2 Major Cavities**

In situations where major cavity defects are present on the molded surface, the following rework procedure is permissible:

#### **NOTE**

Where the cavity defects are present only in the taper portion of the mold, confine the rework procedure to this taper portion of the mold only.

- a. Mask the entire outside of the electrical connector with four or more tape wraps. Mask cable sheath immediately adjacent to the termination of the taper portion of the cable molding with four or more tape wraps.

- b. Use a high-speed rotary tool, equipped with a cutter bit to remove a maximum of 2.54 mm (0.100 in)  $\pm$  0.064 mm (0.0025 in) from the entire surface or from the taper portion only of the cable molding.

**CAUTION**

Extreme care must be exercised by the operator to avoid nicking or in any manner touching the cutter to the electrical connector or cable sheath.

- c. Clean the area to be repaired with a nonmetallic bristled brush or apply a jet of clean, dry air 620 kPa (90 psi) (gage) maximum to the area.
- d. Using a mold identical to the mold with which the original molding was accomplished, remold in accordance with 5.5.2.
- e. Curing shall be completed in accordance with 5.5.3.

**5.6.3 Inspection**

All rework shall be inspected as outlined in 5.5.4.

**5.7 Reports**

Reports shall be as required by the procuring activity.

**6. NOTES**

**6.1 Intended Use**

This standard is intended to be used in the establishment of uniform engineering practices and methods and to ensure the inclusion of essential requirements in the fabrication of electrical terminations for cables used in instrumentation and control systems of facilities, systems, and equipment used to support the operations of test, checkout, servicing, and launch of space vehicles and payloads at KSC.

NOTICE. The Government drawings, specifications, and/or data are prepared for the official use by, or on behalf of, the United States Government. The Government neither warrants these Government drawings, specifications, or other data, nor assumes any responsibility or obligation, for their use for purposes other than the Government project for which they were prepared and/or provided by the Government, or any activity directly related thereto. The fact that the Government may have formulated, furnished, or in any way supplied the said drawings, specifications, or other data is not to be regarded, by implication or otherwise, as licensing in any manner the holder or any other person or corporation nor conveying the right or permission to manufacture, use, or sell any patented invention that may relate thereto.

KSC-STD-132  
Revision D, Change 1

Custodian:

NASA – John F. Kennedy Space Center  
Kennedy Space Center, Florida 32899

Preparing Activity:

John F. Kennedy Space Center  
Engineering Directorate  
Electrical Division

**APPENDIX A. ILLUSTRATIONS**

The following illustrations\* are included in this appendix:

<b>Figure</b>	<b>Title</b>	<b>Page</b>
Figure 1.	Definition of Potting and Molding Terms .....	30
Figure 2.	MIL-DTL-26482 Connectors (Sheet 1 of 2).....	31
Figure 3.	Shield/Shield Adapter .....	33
Figure 4.	SAE AS 50151 Connectors (Sheet 1 of 2).....	34
Figure 5.	MIL-DTL-22992 Connectors (Sheet 1 of 3).....	36
Figure 6.	Banana Plug (Configuration 1) .....	39
Figure 7.	Banana Plug (Configuration 2) .....	39
Figure 8.	360° Overall Shield Termination Using a 120E0600001 Mold Adapter .....	40

\*These illustrations show standard configuration dimensions for cable assembly terminations of SAE AS 50151, MIL-DTL-22992, MIL-DTL-26482, and banana plugs. MIL-DTL-38999, MSFC-SPEC-40M38277, MSFC-SPEC-40M38298, and MSFC-SPEC-40M39569 connectors shall be molded similar to the MIL-DTL-26482 connectors. These illustrations do not take into account the insertion of electronic devices into cable molding terminations or show 360-degree shield terminations. Overall shields shall be terminated to each connector backshell 360 degrees at both ends of the cable. Figure 8 illustrates 360 degree overall shield termination using a 120E0600001 mold adapter. Individual design sheets may be more detailed than the illustrations.

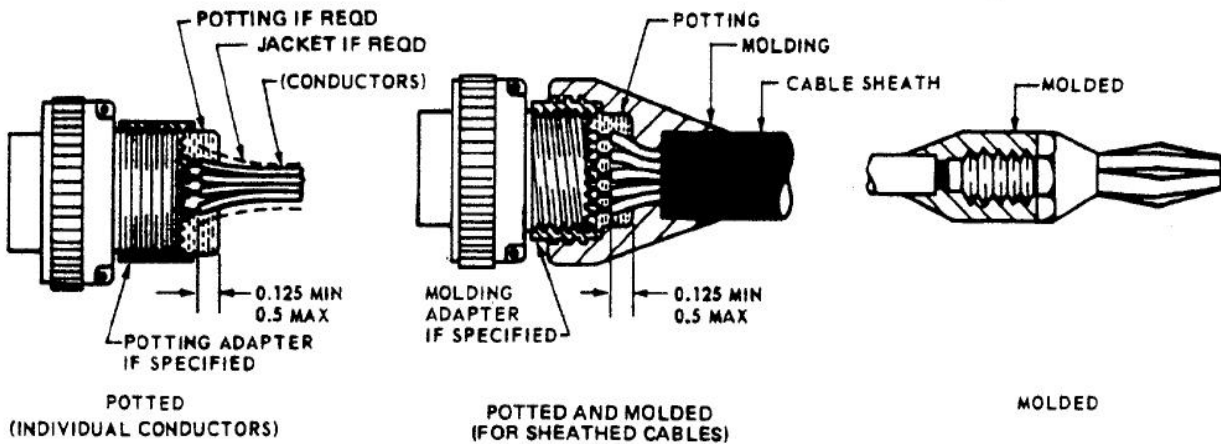
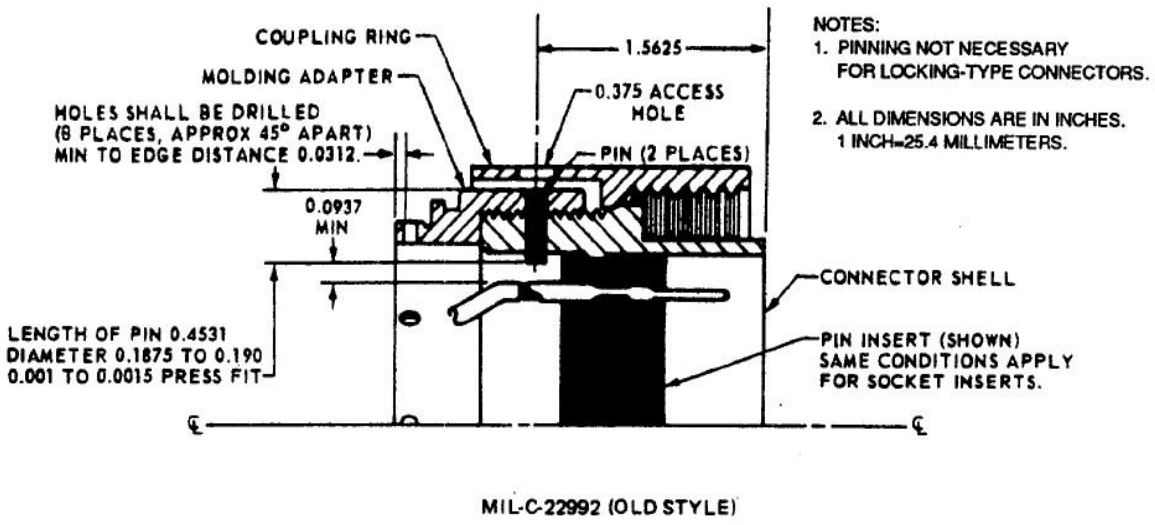

IF REQUIRED BY THE DESIGN DRAWINGS, POTTING WITH EPOXY SHALL BE USED ONLY OVER EXPOSED CONDUCTOR TERMINATIONS.

Figure 1. Definition of Potting and Molding Terms



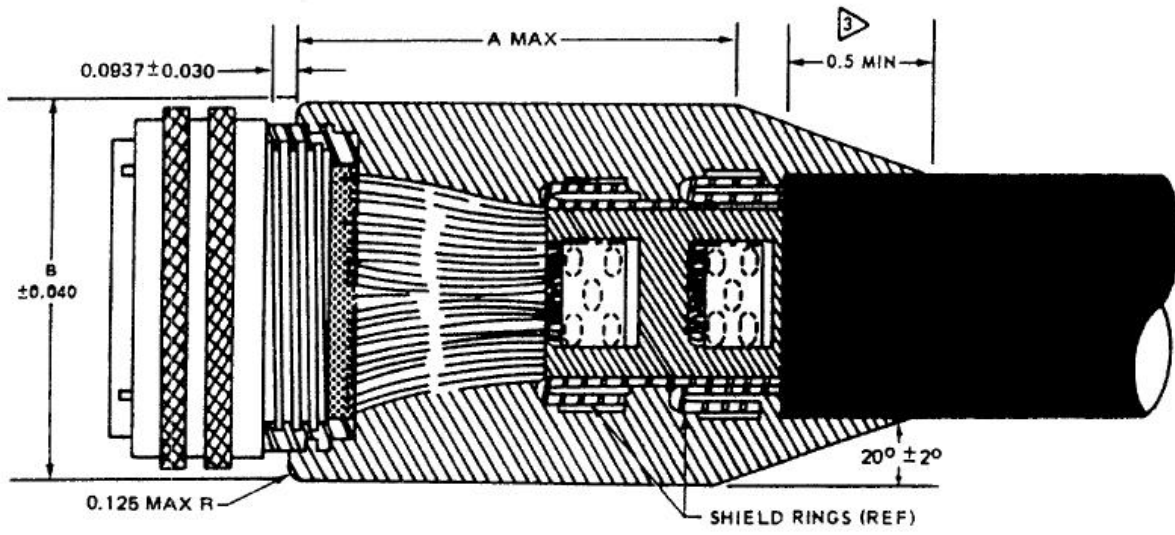

MIL-C-26482 CABLE PLUG, DOUBLE-SHIELDED CABLE

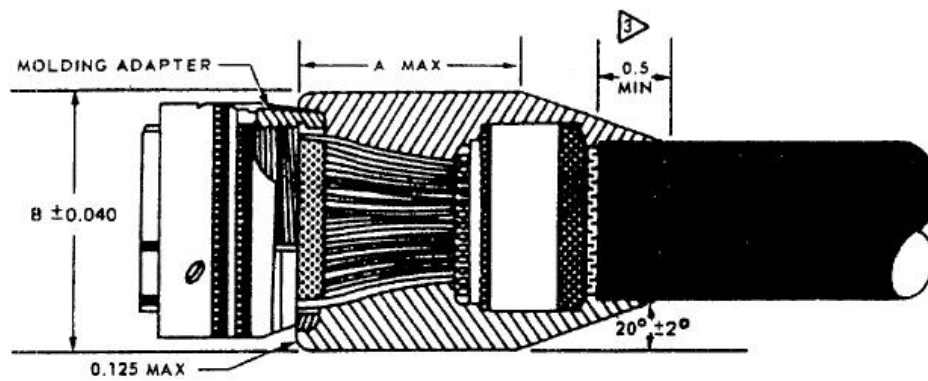

MIL-C-26482 PLUG, SINGLE-SHIELDED CABLE

NOTES:

1. ALL DIMENSIONS ARE IN INCHES. 1 INCH=25.4 MILLIMETERS.
2. SEE SHEET 2 FOR DIMENSION TABLE.
3. FOR BULK CABLE LESS THAN 0.60 DIAMETER USED WITH SHELL SIZE 10SL, 14, AND 14S, MINIMUM INSERTION IS 0.375.
4. OMIT EPOXY POTTING IF CONNECTOR IS CRIMP TYPE (SERIES 2).

Figure 2. MIL-DTL-26482 Connectors (Sheet 1 of 2)

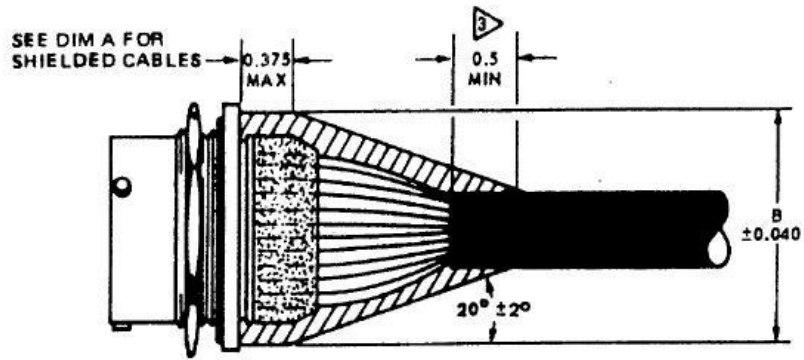

MIL-C-26482, SERIES 1, JAM NUT RECEPTACLE TYPE  
 SERIES 2 JAM NUT CONNECTORS HAVE BACKTHREADS.

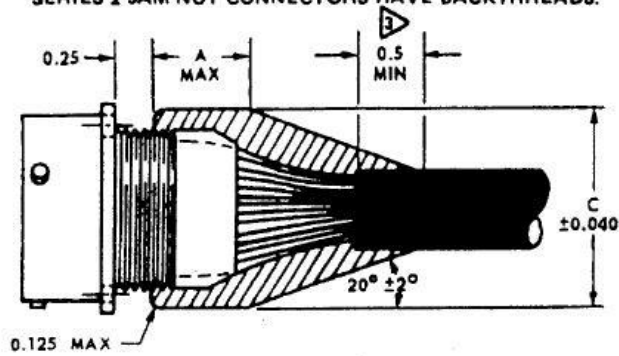

MIL-C-26482 FLANGE RECEPTACLE

(MOLD ONLY CONNECTORS WITH SHEATHED CABLES UNLESS OTHERWISE SPECIFIED)

MIL-C-26482 BOX-MOUNTING-TYPE RECEPTACLE (NOT THREADED)

SHELL SIZES		6	8	10	12	14	16	18	20	22	24
UNSHIELDED	A DIM	1.000	1.000	1.000	1.000	1.000	1.000	1.000	1.000	1.000	1.000
	B DIM	.750	.875	1.000	1.125	1.250	1.375	1.500	1.625	1.750	1.875
	C DIM	.500	.625	.750	.875	1.000	1.125	1.250	1.375	1.500	1.625
SINGLE SHIELDED	A DIM	1.500	1.500	1.500	1.500	1.500	1.625	1.750	2.000	2.250	2.500
	B DIM	SAME SIZE AS FOR UNSHIELDED CABLES									
	C DIM	SAME SIZE AS FOR UNSHIELDED CABLES									
DOUBLE SHIELDED	A DIM	1.500	1.625	1.750	1.875	2.000	2.125	2.250	2.500	2.750	3.000
	B DIM	SAME SIZE AS FOR UNSHIELDED CABLES									
	C DIM	SAME SIZE AS FOR UNSHIELDED CABLES									

NOTE: ALL DIMENSIONS ARE IN INCHES. 1 INCH=25.4 MILLIMETERS.

Figure 2. MIL-DTL-26482 Connectors (Sheet 2 of 2)

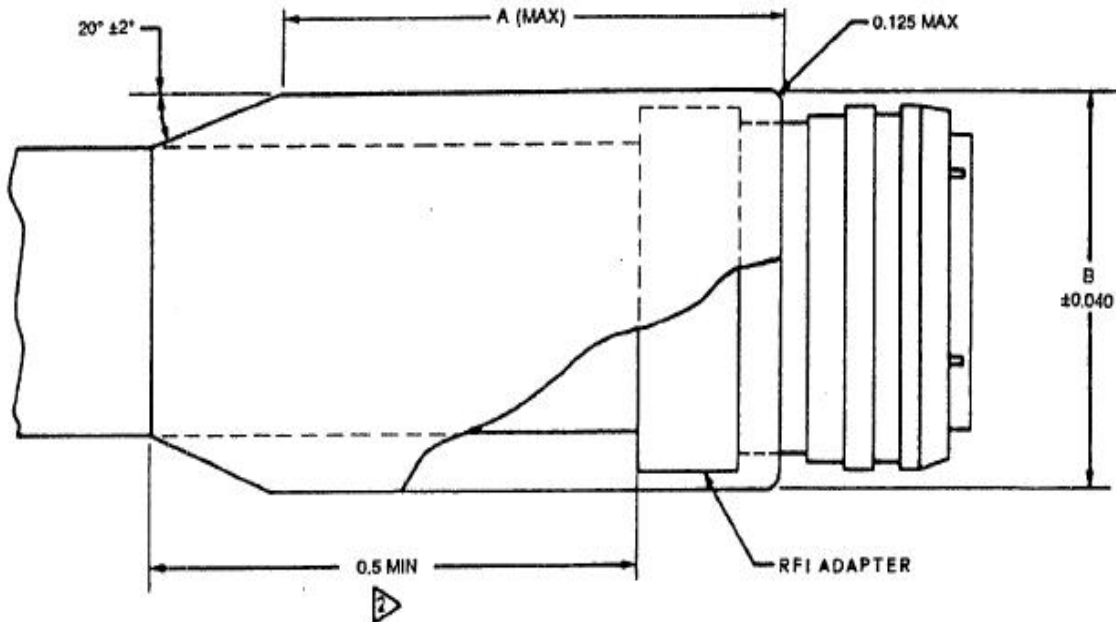

CONN SHELL SIZE	DIMENSIONS	
	A	B
8	1.40	1.000
12	1.40	1.375
14	1.50	1.375
24	2.50	1.750

**NOTES:**

1. ALL DIMENSIONS ARE IN INCHES. 1 INCH=25.4 MILLIMETERS.
2. FOR BULK CABLE LESS THAN 0.60 DIAMETER USED WITH SHELL SIZE 10SL, 14, AND 14S, MINIMUM INSERTION IS 0.375.

**Figure 3. Shield/Adapter**

Refer to 120E0600001, tables 3 to 7 for mold adapter dimensioning details.

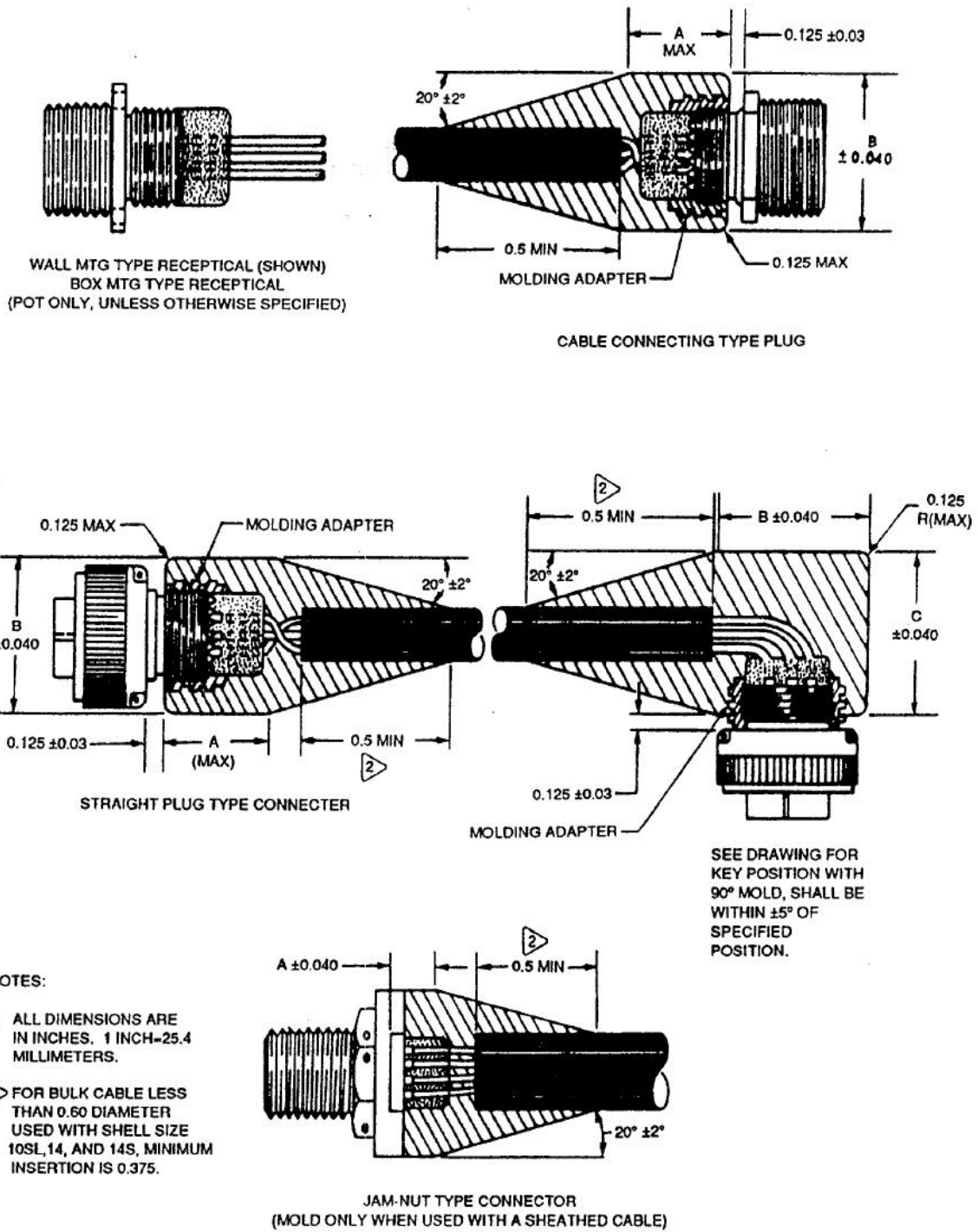
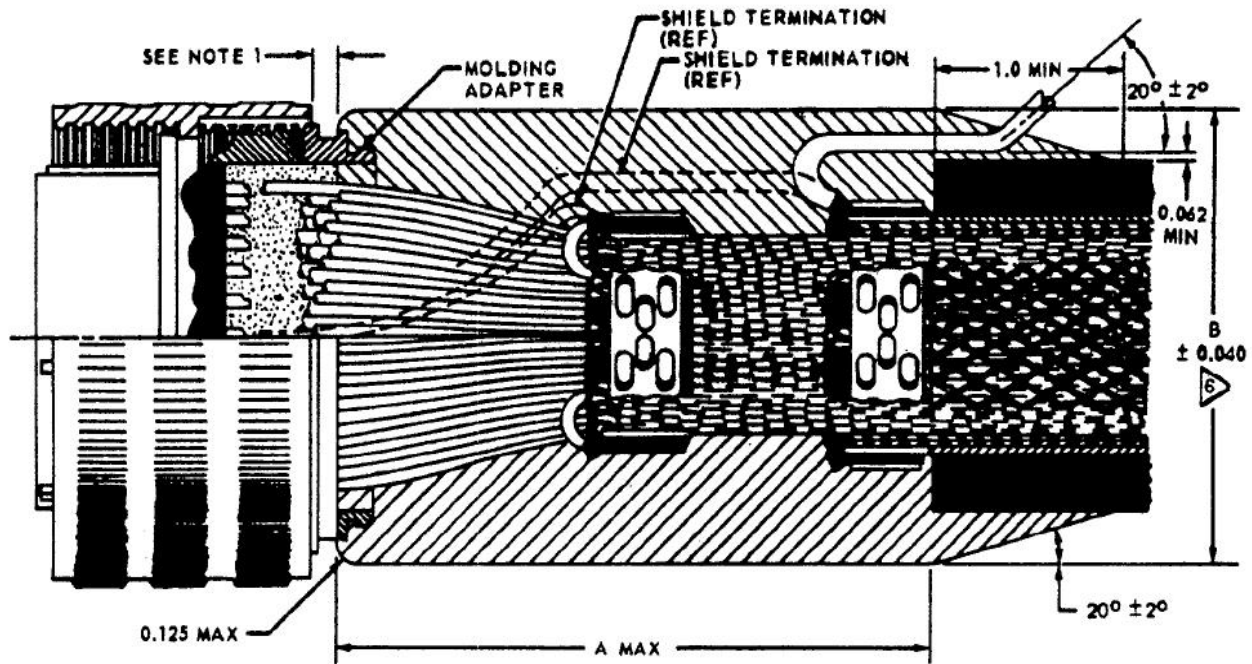

Figure 4. SAE AS 50151 Connectors (Sheet 1 of 2)

Shell Size	A Dimension (Unshielded)	A Dimension (Shielded)	B Dimension (Any)	C Dimension (Any)
10SL	0.625	1.000	1.125	1.125
12S	0.625	1.000	1.187	1.187
14S	0.625	1.000	1.312	1.312
16S	0.625	1.000	1.437	1.437
18	1.125	1.250	1.562	1.562
20	1.250	1.375	1.750	1.750
22	1.250	1.500	1.812	1.812
24	1.375	1.625	2.000	2.000
28	1.500	1.875	2.250	2.250
32	1.500	2.000	2.500	2.500
36	1.500	2.250	2.750	2.750

NOTE: ALL DIMENSIONS ARE IN INCHES. 1 INCH = 25.4 MILLIMETERS.

Figure 4. SAE AS 50151 Connectors (Sheet 2 of 2)



SERVICE CLASS P OR R

NOTES:

1. WHEN MOLDING HEAVY-DUTY FLANGE MOUNT RECEPTACLE, ETC. CONNECTORS (WHERE REQUIRED), NO MOLDING SLEEVE IS REQUIRED; BUT THIS DIMENSION MUST BE HELD TO 0.1875 INCH MINIMUM.
  2. LOCATIONS OF SHIELD RINGS ARE APPROXIMATE AND SHOW ONLY A TYPICAL CASE.
  3. JAM NUT RECEPTACLES WITH NO THREADS ON THE REAR OF THE CONNECTOR SHALL BE MOLDED SIMILAR TO THE MIL-C-5015 CONNECTORS.
  4. ALL DIMENSIONS ARE IN INCHES. 1 INCH=25.4 MILLIMETERS.
- 5 TORQUE COUPLING NUT AND SHIELD NUT TO REQUIREMENTS OF 5.2.2.5 BEFORE POTTING AND MOLDING, ENSURE LOCKING TEETH ARE ENGAGED TO PREVENT ROTATION.
- 6 THE MOLDING SLEEVE FOR THE NEXT LARGER SHELL SIZE MAY BE USED WHEN THE PROPER SIZE IS NOT AVAILABLE.

Figure 5. MIL-DTL-22992 Connectors (Sheet 1 of 3)

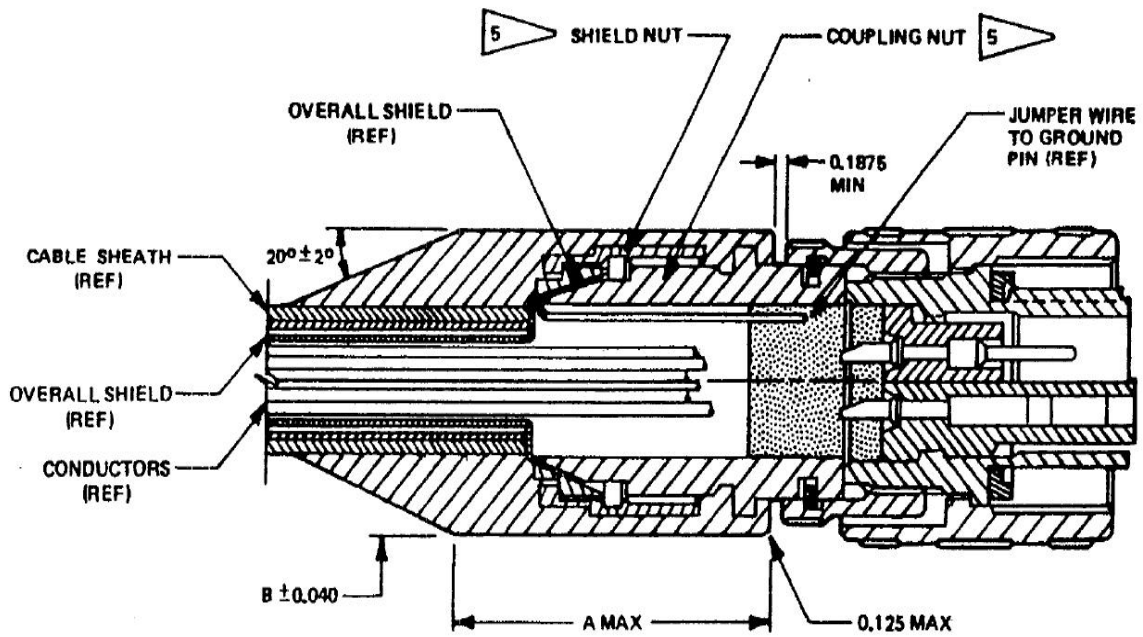

NOTE:  
ALL DIMENSIONS ARE IN INCHES.  
1 INCH = 25.4 MILLIMETERS.

SERVICE CLASS L  
360° SHIELD TERMINATION

Figure 5. MIL-DTL-22992 Connectors (Sheet 2 of 3)

Service Class P or R				
Shell Size	A Dimension Unshielded	A Dimension 1 Shield Rings	A Dimension 2 Shield Rings	B Dimension
10	1.000	2.000	2.500	1.250
12	1.000	2.000	2.500	1.250
13	1.000	2.000	2.500	1.250
14	1.000	2.000	2.500	1.250
15	1.000	2.000	2.500	1.500
16	1.000	2.000	2.500	1.500
17	1.000	2.000	2.500	1.500
18	1.250	2.000	2.500	1.500
20	1.250	2.500	3.000	1.750
22	1.500	2.500	3.000	2.000
24	1.500	2.500	3.000	2.250
28	1.750	3.000	3.500	2.375
32	2.000	3.000	3.500	2.500
36	2.000	3.000	3.500	2.750
40	2.000	3.500	4.000	3.000
44	2.000	3.500	4.000	3.250
Service Class L				
Shell Size	A Dimension Unshielded	A Dimension Shielded	B Dimension	
22	--	3.00	1.860	
24	--	3.00	2.250	
40	--	4.00	3.250	

NOTE: ALL DIMENSIONS ARE IN INCHES. 1 INCH = 25.4 MILLIMETERS.

Figure 5. MIL-DTL-22992 Connectors (Sheet 3 of 3)



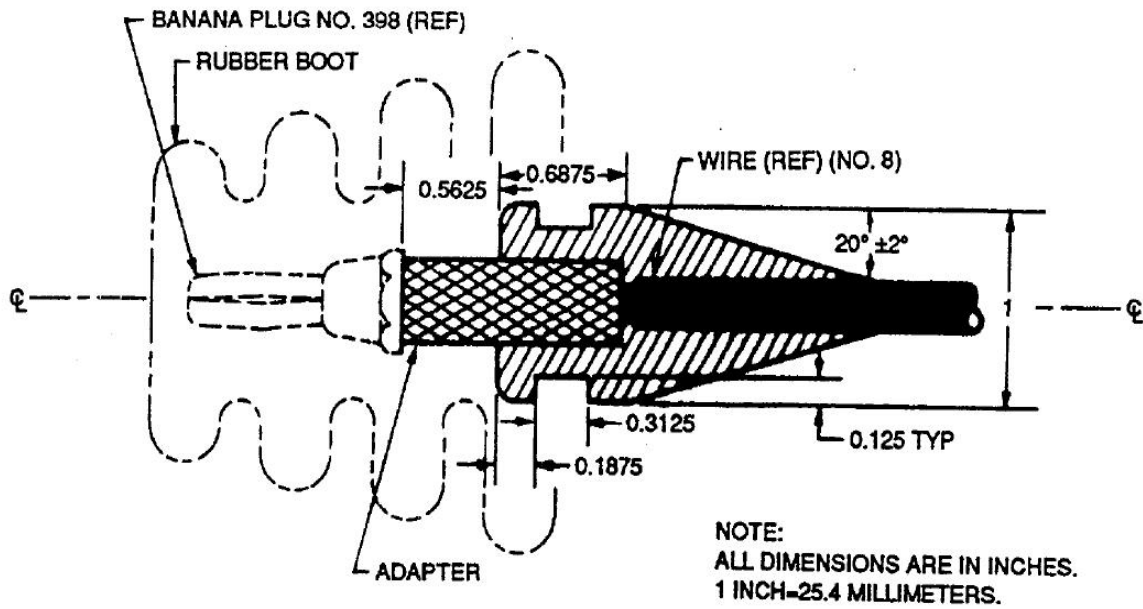
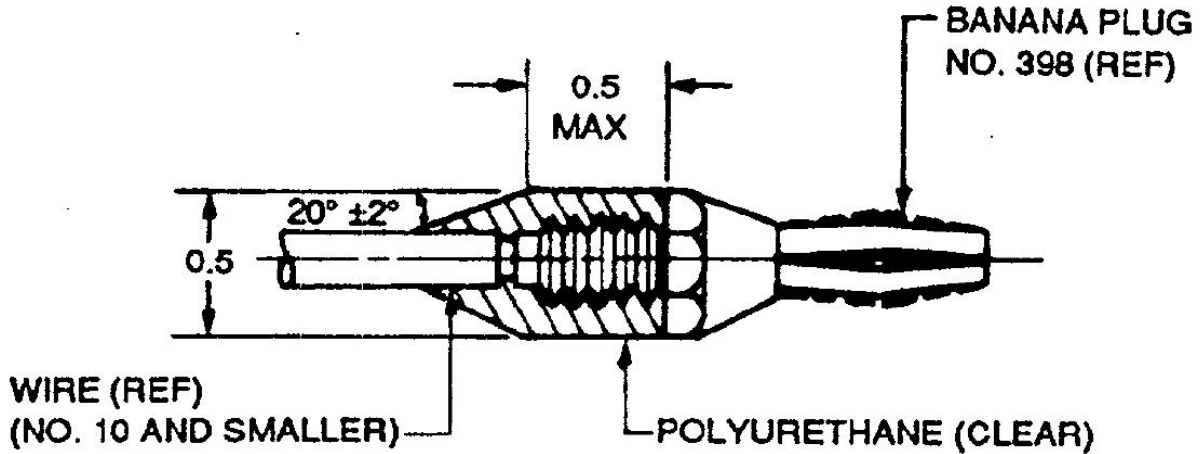
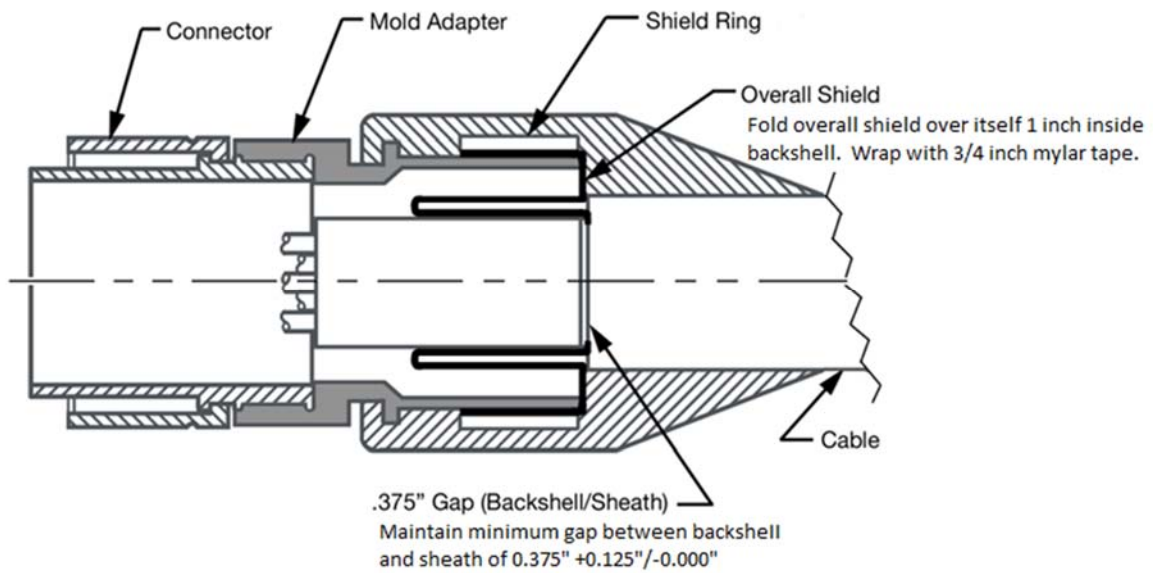

Figure 6. Banana Plug (Configuration 1)



NOTE:  
ALL DIMENSIONS ARE IN INCHES.  
1 INCH=25.4 MILLIMETERS.

Figure 7. Banana Plug (Configuration 2)



**Figure 8. 360° Overall Shield Termination Using a 120E0600001 Mold Adapter**

## APPENDIX B. GUIDELINE FOR FABRICATING MOLDS USED WITH ELASTOMERIC COMPOUNDS TO MOLD ELECTRICAL CONNECTORS AND CABLE SHEATHS

### B.1 Introduction

This guideline provides information to aid electrical cable fabricators to meet the requirements of KSC-STD-132. These guidelines include information on making patterns (also known as “billets”); mold boxes in which patterns are placed for casting molding compound in order to make mold halves; and machining, assembling, and preparing molds to the cable assembly. Although requirements are stated in the main text of KSC-STD-132, some text is repeated here for reference and clarity. This guideline covers both the shop and field processes for potting and molding (prepotting and overmolding) KSC electrical cable assemblies.

### B.2 Reference Documents

- a. 120E0600001, Adapter Connector Molding 360° Shield Termination, provides dimensions for patterns, molds, and marking.
- b. 120E3100003, Electrical Fabrication Requirements, provides an overall reference to other related requirements.

### B.3 Definitions

For the purpose of this document, the following definitions shall apply.

**pattern (also called “billet”):** a physical representation of a completed cable mold that has been split into equal halves. Each half is attached to the inside of a mold box’s side for alignment and to cast the mold. See Figure 9.



Figure 9. Typical Pattern (also called “Billet”)

**mold box:** a container used to cast a mold half. Two mold boxes are required to cast the mold pattern, or one mold box could be used twice to provide the complete pattern. See Figure 10.

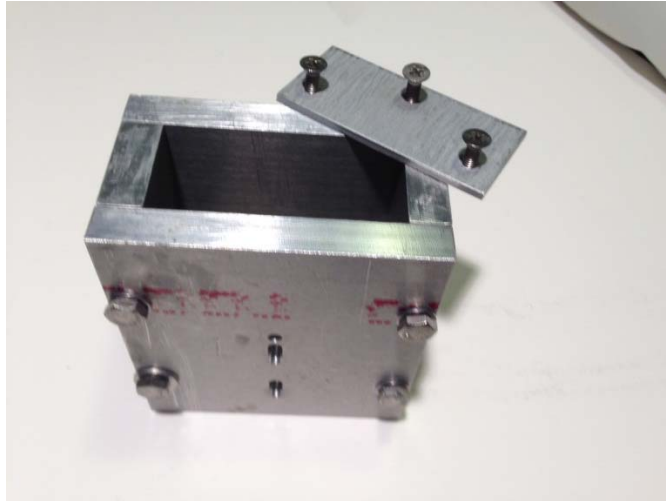

**Figure 10. Typical Mold Box with Bottom Insert Resting on Top**

**mold:** the hollow epoxy-based container used to give shape to a two-part mix of liquid elastomeric compound cast into a mold box. See Figure 11.



**Figure 11. Completed Mold Halves with Completed Cable Assembly End**

**molded cable assembly:** the overmolded encapsulation of a connector backshell to a cable sheath for a cable assembly. See Figure 12.



**Figure 12. Typical Cable Assembly Showing One End Terminated**

#### **B.4 General Guidelines**

- a. Pattern dimensions should be consistent with connector molding ring adapter sizes and cable sheath diameters to prevent leakage of the polyurethane molding compound. Patterns are best made using aluminum 6061-T6 polished on the mold facing surfaces to at least a 25 microfinish; however, a smaller microfinish is preferable to ensure a glossy end product. Patterns can be made from bar stock, turned in a lathe to the correct size, and precisely parted using an electrical discharge machining (EDM) resulting in no more than 0.254 mm (0.010 in) out-of-round when the halves are mated. The use of the EDM process is recommended. The patterns can also be made from two aluminum blocks joined together with flat surfaces and the block's ends tack-welded then machined in a lathe to meet the correct size.
- b. Mold boxes should be made using aluminum 6061-T6 stock plates that are 0.375 in to 0.500 in thick. The inside dimensions of the mold box should accommodate an adequate thickness of the Magnolia epoxy to provide strength and sufficient mass to maintain proper heat distribution when curing the polyurethane compound. Alignment of the mold halves is important to ensure the polyurethane cable mold is symmetrical. A mold release is needed in the mold's cavity to prevent a pattern from sticking to the epoxy mold.
- c. Mold details include alignment of the mold halves to drill the clamping bolt holes using an internal plastic alignment "shop aid" to match the position of each mold half when mated to accurately drill the bolt holes. An alternate alignment method is to mate and match the pattern halves, rotating them from the casting position and placing them back into the mold's cavity, and then to close and clamp the mold and drill the holes. There should be at least two bolt holes on each side of the mold to provide clamping and proper sealing to prevent any polyurethane compound leakage. Alignment pins could be considered for ensuring acceptable alignment; however, maintaining close tolerance of the bolt hole's internal diameter and the bolt's outer diameter can achieve proper alignment. Once the mold halves have been bolted together, fill holes and vent holes can be added to the mold. Holes are needed for accessing the mold cavity to fill and vent the epoxy mold.
- d. Machining the mold is necessary for providing precision holes for clamping the mold halves together, providing a hole to insert liquid polyurethane into the mold cavity, venting the cavity as it is being filled, determining the cavity is completely filled, and releasing any bubbles that may have developed while filling. Drilling a proper size hole in the aluminum plate is necessary for assembling the mold to the molding ring adapter. A proper-size hole is also necessary on the rear of the mold for clamping the cable sheath.

## **B.5 Detailed Guidelines**

### **B.5.1 Pattern Details**

- a. Dimensions for the patterns can be found in 120E0600001.
- b. The connector end of the pattern should have a slight radius, approximately 1.5875 mm (1/16 in) into 3.175 mm (1/8 in), where the pattern interfaces with the aluminum end plate inside the mold box. This interface should never be 90 degrees because right angles tend to attract and capture bubbles in the mold compound while the mold cavity is being filled with the mold compound Magnolia epoxy. Note the 20-degree taper of the pattern that provides strain relief between the connector and the cable.
- c. The pattern's cable sheath end should measure 6.35 mm (1/4 in) diameter and extend beyond the top of the Magnolia epoxy mold. This provides a 6.35 mm (1/4 in) hole in the mold in order to provide a center for the correct-size hole in the mold for clamping the cable sheath.
- d. The outside diameter of the finished molded assembly should be approximately 3.175 mm (1/8 in) larger in diameter than the diameter of the molding ring adapter's largest diameter. See Figure 9.
- e. The pattern should be turned to size from a round aluminum 6061-T6 bar stock of a size nearest the final outside diameter of the pattern and cut precisely in half using an EDM that removes no more than 0.254 mm (0.010 in) of material during the cut. This should be the least expensive method for fabricating the patterns.
- f. The finished side that will contact the mold should be polished to achieve at least a 25 microinch surface, preferably less for an almost mirror finish.
- g. The flat or underneath side surface should be permanently marked to identify its use for making other molds. This flat side should have two holes along the center of the long axis to mount the pattern inside the mold box.
- h. The holes should be drilled and tapped for 1/4-20 in machine screws approximately 25.39 mm (1.0 in) apart on the center of the long axis to mount patterns inside the mold box. These holes should match the holes located in the mold box.
- i. The finished mold halves should be stored together and wrapped in a soft material to prevent any damage or scratches to the pattern's surfaces.
- j. Patterns should be marked to identify their use, be protected in storage, and be capable of multiuse applications.

- k. Multiuse means “many times,” as well as for use with different-diameter cable sheaths.
- l. The pattern should be coated with paste wax, such as Meguiar’s Cleaner Paste Wax (part number A1214) or equivalent, to prevent the pattern from sticking to the Magnolia epoxy in the mold box.

**NOTE**

Valspar 225 mold release is used on cable molds only before being filled with polyurethane molding compound to prevent the finished molded cable from sticking to the Magnolia epoxy mold.

- m. A drawing/sketch should be made to document each pattern’s dimensions.

**B.5.2 Mold Boxes Details**

- a. Mold boxes should be made using aluminum 6061-T6 stock plates that are 0.375 in to 0.500 in thick.
- b. The inside dimensions of the mold box should allow a minimum thickness of 15.875 mm (5/8 in) from the inside of the mold cavity to the outer sides of the mold.
- c. For each mold, two mold boxes should be drilled alike for attaching the patterns inside the mold box so that the resultant mold will be aligned.
- d. Magnolia epoxy (part number 1012) should be used to cast the molds.
- e. The inside of the mold box should be coated with paste wax, such as Meguiar’s Cleaner Paste Wax (part number A1214) or equivalent, to prevent the pattern from sticking to the Magnolia epoxy in the mold box.
- f. Dimensions for fabricating mold boxes have not been formally documented. These dimensions can be determined by the pattern size.
- g. The material presently used to fabricate the mold boxes is 1/2 in-thick aluminum 6061-T6. A 3/8 in-thick plate could be substituted, but no less thickness should be considered because the mold box needs metal mass in order to be strong and to conduct heat evenly to the Magnolia epoxy during the curing time in the oven.
- h. The mold boxes should be marked to identify their application for use with different molds. See 120E0600001, sheets 2 through 5, which specify the mold sizes in the last column to the right. Mold boxes will need an aluminum plate placed in the bottom for insertion to the bottom of the epoxy mold. See Figure 10.



### **B.5.3 Mold Details**

- a. A 1/8 in aluminum 6061-T6 plate, sized to fit snugly inside the mold box is placed at the bottom and secured with fasteners that will be cast into the bottom of the mold material. This plate strengthens the forward part of the mold to prevent the epoxy from breaking where it meets the molding ring adapter groove. See Figure 10.
- b. The pattern halves should be bolted snug-tight inside the mold boxes.
- c. Machining may begin once the mold half is cast, cured, and returned to room temperature, and the mold halves are aligned, mated, and temporarily clamped.
- d. Before machining, a drawing/sketch should be made for each type of mold assembly and kept as a record during fabrication.
- e. Bolt holes for clamping should be drilled precisely to ensure proper alignment. When using 3/8 in bolts for clamping, the bolt holes should be drilled no larger than 0.385 in to ensure a compliant alignment.
- f. There should be at least two bolt holes on each side of the mold. Once the bolt holes are drilled, four bolts should be used to clamp the two mold halves together.
- g. After the mold halves are bolted together, the hole for mating the aluminum plate to the molding ring adapter can be drilled, as specified in 120E0600001, Column M, sheets 2 through 5.
- h. After measuring the cable sheath diameter, the hole for clamping the cable sheath can be drilled in the rear of the mold.
- i. A fill hole is drilled to accommodate a 1/4-20 inch plug. It is located close to the bottom of the mold to ensure that the compound rises from the bottom to the top in the mold cavity. See Figure 11.
- j. After these holes have been drilled, the mold is opened and each half can be machined to provide two vent holes at the top of the cavity mold.
- k. The vent hole should be approximately 4.7625 mm (3/16 in) wide by 3.175 mm (1/8 in) deep, making the total size of 4.7625 mm (3/16 in) by 6.35 mm (1/4 in) deep when reassembled. Note the typical finished cable assembly shown in Figure 12.
- l. Before being used, the Magnolia epoxy mold halves are dipped in Valspar 225 mold release and placed in a rack to drip-dry. See Figure 13.



**Figure 13. Drip Table/Rack and Tilted Mold Boxes for Releasing Entrained Air**

- m. Before the mold is closed, the cable assembly's configuration is visually checked to verify that the cable assembly fabrication requirements of 120E3100003 have been met.

# STANDARDIZATION DOCUMENT IMPROVEMENT PROPOSAL

## INSTRUCTIONS

1. The preparing activity must complete blocks 1, 2, 3, and 8. In block 1, both the document number and revision letter should be given.
2. The submitter of this form must complete blocks 4, 5, 6, and 7.
3. The preparing activity must provide a reply within 30 days from receipt of the form.

NOTE: This form may not be used to request copies of documents, nor to request waivers or clarification of requirements on current contracts. Comments submitted on this form do not constitute or imply authorization to waive any portion of the referenced document or to amend contractual requirements.

### **I RECOMMEND A CHANGE:**

1. DOCUMENT NUMBER

KSC-STD-132, Revision D, Change 3

2. DOCUMENT DATE

March 3, 2017

3. DOCUMENT TITLE

**Potting and Molding Electrical Cable Assembly Terminations, Standard for**

4. NATURE OF CHANGE *(Identify paragraph number and include proposed rewrite, if possible. Attach extra sheets as needed.)*

5. REASON FOR RECOMMENDATION

### **6. SUBMITTER**

a. NAME *(Last, First, Middle Initial)*

b. ORGANIZATION

c. ADDRESS *(Include Zip Code)*

d. TELEPHONE *(Include Area Code)*

7. DATE SUBMITTED

### **8. PREPARING ACTIVITY**

a. NAME *(Last, First, Middle Initial)*

Denson, Erik C.

b. ORGANIZATION

Engineering Directorate, Electrical Division

c. ADDRESS *(Include zip code)*

Kennedy Space Center, FL 32899