

**KSC-STD-E-0022, Change 2**

**February 5, 2019**

Supersedes  
KSC-STD-E-0022, Change 1  
August 15, 2016

**BONDING, GROUNDING, SHIELDING,  
ELECTROMAGNETIC INTERFERENCE, LIGHTNING  
AND TRANSIENT PROTECTION, DESIGN  
REQUIREMENTS FOR GROUND SYSTEMS**



**ENGINEERING DIRECTORATE**

---

National Aeronautics and  
Space Administration

**John F. Kennedy Space Center**

KSC FORM 16-12 (REV. 6/95) PREVIOUS EDITIONS ARE OBSOLETE (CG 11/95)

KDP-F-5407 BASIC





**KSC-STD-E-0022, Change 2**

**February 5, 2019**

Supersedes  
KSC-STD-E-0022, Change 1  
August 15, 2016

**BONDING, GROUNDING, SHIELDING,  
ELECTROMAGNETIC INTERFERENCE, LIGHTNING  
AND TRANSIENT PROTECTION, DESIGN  
REQUIREMENTS FOR GROUND SYSTEMS**

Approved by:



---

Shawn M. Quinn  
Director, Engineering

**JOHN F. KENNEDY SPACE CENTER, NASA**

**RECORD OF REVISIONS/CHANGES**

<b>REV LTR</b>	<b>CHG NO.</b>	<b>DESCRIPTION</b>	<b>DATE</b>
		Basic issue.	April 11, 2013
	1	Updated Signature page, added Record of Revisions page, updated TOC to reflect Change 1, deleted GSFC from the Acronym List, added NFPA 79 to 2.2 and 5.1.3, deleted GSFC Code 560 from 2.2 and 5.9, added 4.6.a and 4.6.b, deleted “components” from 5.1.4.a, updated 5.1.6.b, added new 5.1.6.c and renumbered existing list, added tailoring and commercial standards language to 5.3.2, updated Note 1 to Table 2, added graph to Note 6 to Table 2, added Note 13 to Table 2, updated 5.6.4.a, added new 5.6.4.b and renumbered existing list, and updated Figure 6 caption.	August 15, 2016
	2	Updated signature page, Record of Revision, and TOC to reflect Change 2. Added EMCMP and FCC to Acronyms list. Added EMI testing requirements to 1.1. Tailoring (1.2) was expanded to cover EMC resting requirements and characterization tests. Added 1.3 on electromagnetic compatibility management plan. Added KDP-P-2713 to 2.1, applicable governmental documents list. Added definition for “Facility Ground” to 3. Deleted bonding requirements for GS in 5.1.1. In 5.1.6, changed milliohms maximum to 100 from 2.5. Removed milliohm specification from 5.1.7. Added detail to 5.1.7.c on bonding to mounting structure. Added information on DC resistance to 5.2.3.b. Added this standard to reference in 5.2.3. Added 5.3.d and NASA Technical Authority on tailored test plans and testing parameters. On Table 2, updated information under Note 1 on tailoring characterization tests and variances. In 5.6.4.d changed milliohms maximum to 100 from 2.5, and in 5.6.4.e changed from 30 milliohm to 1 ohm. In 5.7.1, changed milliohms from 25 to 1. In 5.7.1.b and 5.7.3.a specified from “minimum 360-degree” to “360-degree.” Added Appendices B and C.	February 5, 2019

## CONTENTS

1.	SCOPE .....	1
1.1	Applicability .....	1
1.2	Tailoring.....	2
1.3	Electromagnetic Compatibility Management Plan .....	2
2.	APPLICABLE DOCUMENTS .....	2
2.1	Governmental.....	2
2.2	Nongovernmental.....	4
2.3	Order of Precedence.....	5
3.	DEFINITIONS.....	6
4.	GENERAL REQUIREMENTS .....	6
4.1	Bonding.....	6
4.2	Grounding .....	6
4.3	Shielding .....	7
4.4	EMI Protection.....	7
4.5	Lightning Protection .....	7
4.6	Electrostatic Discharge (ESD) Protection.....	7
4.7	Transient Surge Protection.....	7
4.8	Fabrication Requirements .....	7
4.9	Installation and Assembly Requirements.....	7
4.10	Ground Systems Interfaces with Flight Systems .....	7
4.11	Code Requirements.....	8
5.	DETAILED REQUIREMENTS.....	8
5.1	Bonding.....	8
5.1.1	Bonding Classes.....	8
5.1.2	Bonding of GS Noncurrent-Carrying Conductive Materials .....	9
5.1.3	Code Requirements .....	10
5.1.4	GS Bonding Effectiveness .....	10
5.1.5	Material Interfaces .....	10
5.1.6	GS Mechanical Subsystems Components.....	10
5.1.7	GS Electrical and Electronic Equipment Panels, Chassis, and Enclosures .....	11
5.1.8	Portable and Mobile GS Electrical/Mechanical Service Carts .....	11
5.2	Grounding of GS Equipment .....	12
5.2.1	Code Requirements.....	12
5.2.2	Types of Grounds (Provided by the Center Operations Facility Designs) .....	12
5.2.3	GS Grounding Effectiveness.....	12
5.2.4	GS Grounding Interfaces with Facility Grounding.....	12
5.2.5	Certified Ground Plates.....	13
5.2.6	Use of Single-Point GS Grounds .....	13

5.2.7	Use of Multipoint GS Grounds .....	14
5.2.8	Ground Special Power (GSP) Grounding .....	15
5.3	Electromagnetic Interference (EMI) .....	17
5.3.1	EMI Testing .....	17
5.3.2	Primary Qualification Test Requirements .....	17
5.3.3	Alternate Qualification Test Requirements .....	21
5.4	GS Testing .....	22
5.5	Shielding .....	22
5.5.1	Code Requirements .....	22
5.5.2	Types of Wire, Harnesses, and Cable Shielding .....	23
5.5.3	GS Shielding Effectiveness of Electrical Enclosures .....	23
5.5.4	Routing and Separation of Signals .....	24
5.5.5	Equipment Rack, Panel and Enclosure Shielding .....	24
5.5.6	Power Cable Shielding .....	25
5.5.7	Instrumentation and Control Cable Shielding .....	25
5.5.8	Operational Communication Cable Shielding .....	25
5.6	GS Lightning Protection .....	25
5.6.1	Code Requirements .....	25
5.6.2	GS Shielded by Lightning Protection Systems .....	26
5.6.3	GS Not Shielded by a Lightning Protection System .....	26
5.6.4	Piping, Tubing, and Ducts (Considered here to be GS) .....	26
5.7	ML (Considered to be GS) .....	28
5.7.1	MLT Access and Service Arms .....	28
5.7.2	MLT GS Enclosures .....	28
5.7.3	MLT Electrical Cables .....	28
5.8	Lightning Detection and Measurement Instrumentation .....	28
5.9	Electrostatic Discharge (ESD) Protection .....	29
5.10	Transient Voltage and Surge Suppression .....	29
5.10.1	Power Line Filtering .....	30
5.10.2	Communication Line Filtering .....	30
5.10.3	Electrically Inductive Component Transient and Surge Suppression .....	30
APPENDIX A.	DISPLAY PLACARDS EXAMPLE .....	32
APPENDIX B.	KSC-STD-E-0022 ELECTROMAGNETIC COMPATIBILITY TAILORING REQUEST FORM (KSC FORM 50-386) .....	33
APPENDIX C.	ELECTROMAGNETIC COMPATIBILITY MANAGEMENT PLAN OUTLINE .....	35

## FIGURES

Figure 1. Single-Point Grounds General-Purpose Ground Method.....	13
Figure 2. Single-Point GS Grounds Typical Single-Point Ground Network for a Control System Housed in a Single Enclosure .....	14
Figure 3. Multipoint GS Grounds .....	15
Figure 4. GSP Grounding for DC Buses in Vehicle .....	16
Figure 5. GSP Grounding for DC Buses in GS .....	16
Figure 6. Typical Methods of Providing Electrical Continuity across Mechanical Joints with Different Conductive Material, such as Aluminum to Steel.....	27

## TABLES

Table 1. Electrical Bond Classes .....	8
Table 2. MIL-STD-461 Tests for GS Certification .....	18

## ABBREVIATIONS, ACRONYMS, AND SYMBOLS

AC	alternating current
ANSI	American National Standards Institute
AWG	American wire gauge
CE	conducted emissions
CFR	Code of Federal Regulations
COTS	Commercial off the shelf
CS	conducted susceptibility
dB	decibel
DC	direct current
EM	electromagnetic
EMC	electromagnetic compatibility
EMCMP	electromagnetic compatibility management plan
EMI	electromagnetic interference
EMITP	Electromagnetic Interference Test Plan
ESD	electrostatic discharge
EUT	equipment under test
FAA	Federal Aviation Administration
FCC	Federal Communications Commission
FS	facility systems
GHz	gigahertz
GS	ground systems
GSE	ground support equipment
GSP	ground special power
GSS	ground support systems
HBM	human body model
IBM	International Business Machines
ICD	interface control document
JEDC	Joint Electron Devices Engineering Council (now the JEDEC Solid State Technology Association)



KNET	Kennedy network
KSC	John F. Kennedy Space Center
LDE	lead discipline engineer
MHz	megahertz
ML	Mobile Launcher
MLP	Mobile Launcher Platform
MLT	Mobile Launcher Tower
MPPF	Multi-Payload Processing Facility
NASA	National Aeronautics and Space Administration
NFPA	National Fire Protection Association
O&C	Operations and Control Building
OEM	original equipment manufacturer
OPR	office of primary responsibility
OPRD	office of primary responsibility designee
RE	radiated emissions
RF	radio frequency
RFI	radio frequency interference
RS	radiated susceptibility
STD	standard
STP	shielded twisted pair
UTP	unshielded twisted pair
V/m	volts/meter
VAB	Vehicle Assembly Building



## **BONDING, GROUNDING, SHIELDING, ELECTROMAGNETIC INTERFERENCE, LIGHTNING AND TRANSIENT PROTECTION, DESIGN REQUIREMENTS FOR GROUND SYSTEMS**

### **1. SCOPE**

This standard provides design and testing requirements for bonding, grounding, shielding, electromagnetic interference (EMI), lightning protection, electrostatic discharge (ESD) protection, transient protection, and surge suppression for electrical and electronic ground systems (GS) to be used at the Kennedy Space Center (KSC). It governs both fixed and portable GS consisting of ground support equipment (GSE), ground support systems (GSS), and operational communications systems that are used in processing, launch, landing, and retrieval sites. This GS standard further defines requirements in KSC-DE-512-SM, Facility Systems, Ground Support Systems and Ground Support Equipment General Design Requirements,

KSC-E-165, Electrical Ground Support Equipment Fabrication, Specification for, KSC-E-166, Installation and Assembly, Electrical Ground Support Equipment (GSE), Specification for, and KSC-GP-864, Vol. IIA, Electrical Ground Support Equipment Cable Handbook, This standard is used in conjunction with the KSC facility standard KSC-STD-E-0012, Facility Grounding and Lightning Protection, Standard for, which provides requirements for facility grounding, bonding and lightning designs. These facility systems provide connections and paths to earth ground for GS through certified ground plates that provide low-impedance paths to the local counterpoise grounds.

Commercial, military, and other government standards are cited where they provide acceptable design requirements for ground systems used at KSC. Where these standards lack sufficient design requirements and testing for KSC ground systems, KSC-developed requirements are provided and the source(s) identified at the end of the requirement statement. Guidance statements that follow the stated requirements are italicized.

This standard, together with KSC-STD-E-0012, creates a comprehensive set of requirements for protecting KSC ground systems from expected electrical disturbances.

#### **1.1 Applicability**

This standard specifies engineering requirements for electrical/electronic ground systems developed for and employed at KSC for NASA programs and projects. This standard, or applicable sections, may be cited in contracts and program documents as a technical requirement or as a reference for engineering guidance. This standard is not intended to apply to institutional and administrative electrical/electronic systems such as telephones and area paging in general purpose use. EMI testing requirements do not apply to standard test equipment and support equipment such as digital multi-meters, oscilloscopes, analyzers, data acquisition equipment, laptops and tablets that meet industry electromagnetic (EMC) or Federal Communication Commission (FCC) regulations (FCC Part 18, FCC Part 15 Subpart A or European Standard EN

55024). Testing should be performed if the radio frequency (RF) environment may cause adverse effects on the equipment that may affect GS, flight hardware, test configuration or test data integrity. This standard does apply when institutional and administrative systems, standard test equipment and support equipment are located within racks and enclosures containing GS.

## **1.2 Tailoring**

Individual provisions of this standard should be and are intended to be tailored (i.e., modified or deleted) to meet specific program and project needs. EMI emission and susceptibility effects to the equipment under test, other GS and flight hardware as well as location, RF environment, and operations should be evaluated to determine appropriate EMC testing requirements. As part of the tailoring process, tests may be deemed as “characterization” tests to determine equipment susceptibility and emissions characteristics. Characterization tests typically do not have pass/fail criteria and do not require a waiver for test exceedances. These tests provide data for analysis and planned operational restrictions. The NASA Technical Authority for electrical and electronic design has the authority to approve tailored tests plans, requirements and specific test parameters to meet the requirements of KSC-STD-E-0022. Request for tailoring of EMC testing requirements shall be documented and approved using KSC Form 50-386, see Appendix B. The tailoring should reflect that the equipment will operate at full performance in its operational environment and will not present interference to other GSE or flight hardware. All tailoring shall be evaluated for use by the appropriate technical authority and the office of primary responsibility designee (OPRD) for this document. See the lead discipline engineers list for KSC specifications and standards in KSC-PLN-5400\_LDE-LIST.

## **1.3 Electromagnetic Compatibility Management Plan**

An electromagnetic compatibility management plan (EMCMP) should be developed for GSE as part of the formulation stage and included as an engineering product in the design review process. See Appendix C for suggested EMCMP content.

## **2. APPLICABLE DOCUMENTS**

The following documents form a part of this document to the extent specified herein. When this document is used for procurement, including solicitations, or is added to an existing contract, the specific revision levels, amendments, and approval dates of documents shall be specified in an attachment to the solicitation/statement of work/contract.

### **2.1 Governmental**

#### Department of Defense

MIL-HDBK-263

Electrostatic Discharge Control Handbook

MIL-STD-1686	Electrostatic Discharge Control Program for Protection of Electrical and Electronic Parts, Assemblies and Equipment (Excluding Electrically Initiated Explosive Devices)
MIL-HDBK-1857	Grounding, Bonding and Shielding Design Practices
MIL-HDBK-419A	Grounding, Bonding, and Shielding for Electronic Equipments and Facilities
MIL-STD-1524	Table of Differential Pressure in Relation to Calibrated Airspeed
MIL-STD-188-124	Grounding, Bonding and Shielding
MIL-STD-461	Requirements for the Control of Electromagnetic Interference Characteristics of Subsystems and Equipment
MIL-STD-464	Electromagnetic Environmental Effects Requirements for Systems
MIL-STD-889	Dissimilar Metals

Federal Aviation Administration (FAA)

FAA-G-2100	Electronic Equipment, General Requirements
FAA-STD-019	Lightning and Surge Protection, Grounding, Bonding and Shielding Requirements for Facilities and Electronic Equipment
FAA-STD-020	Transient Protection, Grounding, Bonding and Shielding Requirements for Electronic Equipment

National Aeronautics and Space Administration (NASA)

NASA-STD-4003	Electrical Bonding for NASA Launch Vehicles, Spacecraft, Payloads and Flight Equipment
NASA-STD-5005	Standard for the Design and Fabrication of Ground Support Equipment
NASA-STD-8739.4	Crimping, Interconnection Cables, Harnesses, and Wiring
PD-ED-1206	Power Line Filters

PD-ED-1213	Electrical Shielding of Power, Signal, and Control Cables
PD-ED-1214	Electrical Grounding Practices for Aerospace Hardware
PD-ED-1225	Conducted and Radiated Emission Design Requirements
PD-ED-1231	Design Considerations for Lightning Strike Survivability

John F. Kennedy Space Center (KSC)

KDP-P-2713	Design Review Process
KSC-DE-512-SM	Facility Systems, Ground Support Systems and Ground Support Equipment General Design Requirements
KSC-GP-864, Vol. IIA	Electrical Ground Support Equipment Cable Handbook
KSC-PLN-5400	Technical Authority and Technical Excellence Implementation Plan
KSC-SPEC-E-0002	Modular Electrical Enclosures, Racks, Consoles, and Accessories, Specification for
KSC-STD-E-0012	Facility Grounding and Lightning Protection, Standard for
KSC-E-165	Electrical Ground Support Equipment Fabrication, Specification for
KSC-E-166	Installation and Assembly, Electrical Ground Support Equipment (GSE), Specification for

(Copies of specifications, standards, drawings, and publications required by suppliers in connection with specified procurement functions should be obtained from the procuring activity or as directed by the Contracting Officer.)

**2.2 Nongovernmental**

American National Standards Institute

ANSI/ESD S20.20	For the Development of an Electrostatic Discharge Control Program for Protection of Electrical and Electronic Parts, Assemblies and Equipment (Excluding Electrically Initiated Explosive Devices)
-----------------	--

Electrostatic Discharge Association/Joint Electron Device Engineering Council  
(ESDA/JEDEC)

JS-0001-2012                      ESDA/JEDEC Joint Standard for Electrostatic Discharge  
Sensitivity Testing – Human Body Model (HBM) –  
Component Level

European Standard (EN)

EN 55024                              Information technology equipment – Immunity  
characteristics – Limits and methods of measurement.

Federal Communications Commission (FCC)

FCC Part 15 Subpart A              FCC Rules and Regulations

FCC Part 18                            FCC Rules and Regulations

National Fire Protection Association (NFPA)

NFPA 70                                National Electrical Code (NEC)

NFPA 77                                Recommended Practices on Static Electricity

NFPA 79                                Electrical Standard for Industrial Machinery

NFPA 780                              Standard for the Installation of Lightning Protection Systems

### **2.3            Order of Precedence**

This Standard establishes requirements and guidance for development of GS. Where this document is adopted or imposed by contract on a program or project, the technical requirements of this document take precedence over technical requirements cited in other documents. This Standard does not supersede nor waive established Agency requirements found in other documentation or Code of Federal Regulations (CFR). Conflicts between this Standard and other requirements documents shall be resolved by the office of prime responsibility designee (OPRD).

### 3. DEFINITIONS

Bonded: an electrical connection between an electrically conductive object and a component of a lightning protection system that is intended to significantly reduce potential differences created by lightning currents.

Facility Ground: The electrically conductive network, including all structures, ground plates and grounding cables bonded to the earth grounding counterpoise

Grounded: connected/connecting to ground or to a conductive body that extends the ground connection.

Ground Support Equipment (GSE): nonflight equipment, systems, or devices specifically designed and developed for a direct physical or functional interface with flight hardware.

*Rationale: Equipment used during the manufacturing of flight hardware is not considered to be GSE. Each program defines when manufacturing ends and processing of the flight hardware begins. If manufacturing equipment is to be used after flight hardware processing begins, it must be designed to meet GSE requirements. GSE does not include tools that are designed for general use and not specifically for use on flight hardware.*

Ground Support System (GSS): equipment or infrastructure (portable or fixed) that provides functional or physical support to GSE. It does not directly interface with flight hardware, although it may supply commodities, power, or data that eventually reaches the flight hardware after being conditioned or controlled by GSE.

*Rationale: Design standards for GSS may be similar to or, at the discretion of the program/project, identical to the design standards for GSE. Protective features designed into the GSE prevent failures from propagating to flight hardware.*

Ground Systems (GS): GSE, GSS, and facility GSS

### 4. GENERAL REQUIREMENTS

#### 4.1 Bonding

Bonding of noncurrent-carrying conductive materials shall provide electrical fault current paths to electrical grounding systems such as ground rods and equipotential ground planes.

#### 4.2 Grounding

Grounding of active current carrying conductors, such a ground special power returns and flight power returns shall be in accordance with the circuit design requirements and be consistent with program/project interface control document (ICD) requirements.



### **4.3 Shielding**

Shielding for electrical racks/enclosures and cables such as data bus, power bus, and low voltage/current shall be provided where sensitive electrical circuits may be subjected to EMI.

### **4.4 EMI Protection**

EMI protection shall be provided for GS to ensure immunity of electrical/electronic circuitry from potential sources of radio frequency (RF) and other electromagnetic fields of interference.

### **4.5 Lightning Protection**

Lightning protection for GS shall be provided where facility lightning protection systems are not adequate or available.

### **4.6 Electrostatic Discharge (ESD) Protection**

Electrostatic discharge (ESD) protection for GS shall be a managed program for minimizing the generation of static electricity as well as protecting electrical circuits from damage due to discharge of voltages from electrostatic sources.

- a. All ESD-sensitive components and assemblies shall be handled using practices in accordance with ESD S20.20, MIL-STD-1686, and MIL-HDBK-263. *Insulator materials should not be used near ESD-sensitive components or assemblies.*
- b. ESD control plans shall be developed in accordance with ANSI/ESD S20.20, or an approved equivalent

### **4.7 Transient Surge Protection**

Transient surge protection for ground systems shall be provided in electrical circuits and power buses where components can be damaged and rendered nonfunctional as determined by the designer.

### **4.8 Fabrication Requirements**

Fabrication requirements for electrical GS shall be in accordance with KSC-E-165.

### **4.9 Installation and Assembly Requirements**

Installation and assembly requirements for electrical GS shall be in accordance with KSC-E-166.

### **4.10 Ground Systems Interfaces with Flight Systems**

Ground systems that directly interface with flight hardware shall be in accordance with NASA-STD-4003 interface requirements.

#### 4.11 Code Requirements

Grounding and bonding of GS shall be in accordance with NFPA 70, in addition to other standards cited within this document for GS designs.

*NFPA 70 is the controlling document for design and implementation safety features and controls for electrical components and systems to ensure safety of personnel from electrical/electronic hazards.*

### 5. DETAILED REQUIREMENTS

#### 5.1 Bonding

Conductive materials not designed as part of the electrical current path (e.g., metallic enclosures, ducting, etc.) shall be bonded to provide low-impedance electrical paths leading to earth ground items for the:

- a. Protection of equipment and personnel from the hazards of lightning discharges.
- b. Establishment of fault current return paths.
- c. Establishment of homogeneous and stable paths for electrical currents.
- d. Minimization of voltages on enclosures and housings.
- e. Protection of personnel from shock hazards.
- f. Prevention of static charge accumulation.

*Reference – MIL-STD-188-124*

##### 5.1.1 Bonding Classes

Table 1 provides a summary of electrical bonding classes. Requirements are based upon the application and purpose of the bond.

**Table 1. Electrical Bond Classes**

	POWER RETURN	SHOCK HAZARD	RADIO FREQUENCY	LIGHTNING	ELECTROSTATIC CHARGE
BOND CLASS	CLASS C	CLASS H	CLASS R	CLASS L	CLASS S
PURPOSE OF BOND	Reduces power and voltage losses. Applies to equipment and structure, which are required to return intentional current through structure.	Protects against fire or shock to personnel. Applies to equipment and structure that may be required to carry fault current in case of a short to case or structure.	Protects equipment from RF emissions. Applies to equipment that could generate, retransmit, or be susceptible to RF. Includes antenna mounts and cable shield connections. Covers wide frequency range.	Protects equipment from lightning effects. Applies to equipment or structure that would carry current resulting from a lightning strike.	Protects against electrostatic discharge. Applies to any item subject to electrostatic charging.

	POWER RETURN	SHOCK HAZARD	RADIO FREQUENCY	LIGHTNING	ELECTROSTATIC CHARGE
BOND CLASS	CLASS C	CLASS H	CLASS R	CLASS L	CLASS S
<b>BOND REQMT.</b>	Requires low-impedance and low-voltage across joints to assure adequate power to the user. Jumpers and straps acceptable.	Requires low-impedance and low-voltage across joints to prevent shock hazard or fire due to short. Jumpers and straps acceptable.	Requires low-RF impedance at high-frequency. Direct contact preferred. No jumpers. Short, wide strap may be used as last resort.	Requires low-impedance at moderate frequency. Bonding components are required to withstand high current without arcing. Straps and jumpers are required to withstand high magnetic forces.	Allows moderate impedance. Jumpers and straps acceptable.
<b>DC BOND RESISTANCE REQMT.</b>	Bonding resistance requirement depends on current.	Bonding resistance requirement, 0.1 ohm or less. Special requirements when near flammable vapors.	Bonding resistance requirement, 2.5 milliohms or less. Low-inductance required.	Bonding resistance requirement depends on current. 500 volts or less across any joint. Low-inductance required.	Typical bonding resistance requirement, 1.0 ohm or less.
<b>FREQ. REQMT.</b>	Low	Low	High	High	Low
<b>CURRENT REQMT.</b>	High	High	Low	High	Low
Low-frequency bonds allow use of straps and jumpers. High-frequency bonds require low-inductance paths. Short straps are sometimes acceptable. High-current bonds require large cross sectional areas. Low-current bonds allow use of small contact areas.					

Low-frequency bonds allow use of straps and jumpers. High-frequency bonds require low-inductance paths. Short straps are sometimes acceptable. High-current bonds require large cross sectional areas. Low-current bonds allow use of small contact areas.

*Reference – NASA-STD-4003*

### 5.1.2 Bonding of GS Noncurrent-Carrying Conductive Materials

Bonding of GS noncurrent-carrying conductive materials shall be accomplished in accordance with one of the following methods:

- a. Bolted with galvanic compatible fasteners
- b. Welded or brazed providing a permanent bond
- c. Brazed or exothermic welds are to be used for bonding steel to copper
- d. Flexible cable or braid are of AWG #6 equivalent conductors or larger

*Soft solder may be used to improve conductivity for joints already secured with mechanical fasteners. Soft solder should never be used to provide mechanical restraint. Flexible conductive braid should be used across shock mounts to the mounting surfaces.*

*Reference – FAA-STD-019, MIL-STD-1524, and MIL-HDBK-1857*

### **5.1.3 Code Requirements**

To ensure safety of personnel from electrical/electronic hazards, NFPA 70 requirements for bonding shall be reviewed and employed in addition to other standards for GS designs.

*NFPA 70 is the controlling document for design and implementation safety features and controls for electrical components and systems. NFPA 79 is supplementary for industrial machinery.*

### **5.1.4 GS Bonding Effectiveness**

- a. All bonds shall have a DC resistance of 2.5 milliohms or less when tested between the bonded joints using a 4-terminal milliohm meter.
- b. The DC resistance across joints or seams, such as finger stock or EMI gaskets, in metallic members to provide electromagnetic shielding shall be 2.5 milliohms or less using a 4-terminal milliohm meter.

Where high-frequency or high-speed signals are used, bonds should also consider techniques for minimizing AC impedance.

*Reference – FAA-STD-019*

### **5.1.5 Material Interfaces**

- a. Prior to bonding, all material surfaces shall be thoroughly prepared to remove all contaminants such as dirt, paint, oxides, nonconductive films, or other foreign matter to expose base metal to permit maximum conductivity.
- b. Prepared surfaces shall be joined within 30 minutes to avoid recontamination.
- c. After bonding, the material surfaces shall be protected from corrosion by methods specified in the design documentation consistent with the surrounding material.
- d. Where dissimilar metals are to be bonded, the selection of materials shall be evaluated for potential galvanic activity and minimized by the use of proper materials.

*Reference – MIL-HDBK-419 and MIL-STD-188-124*

### **5.1.6 GS Mechanical Subsystems Components**

- a. Moveable joints, such as hinges and bearings, shall have an electrical bonding strap of at least AWG #6 flexible copper wire placed across the joints to provide a low-impedance (100 milliohms maximum) path for fault currents to be conducted around the moveable joint.

- b. Mechanical joints are not acceptable conductive electrical paths where oxides may develop in time such that the mechanical joint will no longer be a satisfactory conductive electrical path.
- c. Mechanical joints are acceptable where the joints are bolted and of similar material with no required bonding clip.
- d. Conductive tubing, piping, and ductwork shall have a continuous electrical path to earth ground.
- e. Nonconductive tubing, piping, and ductwork shall be treated to prevent static charges from building due to flow dynamics from the media. Conductive covering or a copper wire wrapped around the outside should be considered in the design to dissipate static charges that develop. All conductive coverings and wires must be grounded at each end, as a minimum.

*Reference – FAA-STD-019 and MIL-HDBK-1857*

#### **5.1.7 GS Electrical and Electronic Equipment Panels, Chassis, and Enclosures**

Electrical equipment racks, panels, and enclosures shall be bonded to each other and connected to a certified facility ground.

- a. Panels shall be bonded to the chassis.
- b. Chassis mounted on slides to the enclosure shall have a flexible bonding strap equivalent to an AWG #6 flexible copper wire or larger to provide a ground path for the panel and chassis to the enclosure and permit full opening and closing of the chassis.
- c. Enclosures shall be bonded to a mounting structure to provide a low impedance path to earth ground.
- d. Cable trays not installed in a facility, but installed as part of GS assemblies shall be in accordance with KSC-STD-E-0012 and KSC-E-166.

*Reference – MIL-HDBK-419 and MIL-STD-188-124*

#### **5.1.8 Portable and Mobile GS Electrical/Mechanical Service Carts**

All noncurrent-carrying metal parts of portable and mobile GS shall be grounded to a facility ground. Tethered bond straps are acceptable when portable GS is used for temporary services.

*Reference – NEC paragraph 250.190, NASA-STD-4003, and KSC-STD-E-0012*

## **5.2 Grounding of GS Equipment**

GS electrical and electronic equipment shall be properly grounded in accordance with applicable codes to protect equipment and personnel from hazards generated by fault conditions, induced voltages, lightning, and static electricity.

*Reference – NFPA 70*

### **5.2.1 Code Requirements**

To ensure safety of personnel from electrical/electronic hazards, NFPA 70 requirements for grounding shall be reviewed and employed in addition to other standards for GS designs.

*NFPA 70 is the controlling document for design and implementation safety features and controls for electrical components and systems.*

### **5.2.2 Types of Grounds (Provided by the Center Operations Facility Designs)**

*Facility grounding systems will be provided in accordance with KSC-STD-E-0012. There will be certified grounding plates placed at specified positions to which GS grounding conductors can be attached. A common single-point ground system tying both instrumentation and power grounds together on grounding plates is in effect for grounding GSS and GSE.*

GS connections to the appropriate facility grounding system shall be in accordance with the circuit design and its grounding requirements.

*Reference – PD-ED-1214*

### **5.2.3 GS Grounding Effectiveness**

- a. Grounding effectiveness shall be verified by test.
- b. Ground systems shall be connected to a certified facility grounding plate or structure via a low-impedance electrical path. The DC resistance across each bonded joint in the path shall not exceed 2.5 milliohms. The total DC resistance measured from electrical equipment enclosures to facility ground including all bonding joints, straps and intermediate bus bars shall not exceed 50 milliohms.
- c. Ground plate impedance measurement to earth ground shall be 10 ohms or less.

*Reference – This Standard and KSC-STD-E-0012*

### **5.2.4 GS Grounding Interfaces with Facility Grounding**

GS grounding shall be designed to connect to ground plates provided by facility designs based upon GS requirements for type, location, circuit frequencies and impedance.

*Reference – KSC-STD-E-0012*

### 5.2.5 Certified Ground Plates

- a. Certified facility grounds are certified ground plates and conductors to facility ground and will be designed and installed in accordance with KSC-STD-E-0012.
- b. Mobile launcher (ML) grounds are certified ground plates, structure, conductors, and connections from the ML to facility ground and shall be designed and provided by the OPR in accordance with KSC-STD-E-0012.

*Reference – This Standard*

### 5.2.6 Use of Single-Point GS Grounds

- a. Signal circuits with frequencies below 2 MHz with interfaces external to the GS equipment shall be balanced and isolated from the chassis.
- b. All power and signal returns and references shall exit equipment on individual connector pins or wires. Components such as transducers using power or shields as returns are excepted from this requirement.
- c. Shield connections shall be continuous and bonded to connector shells that are, or will be, grounded when mated.

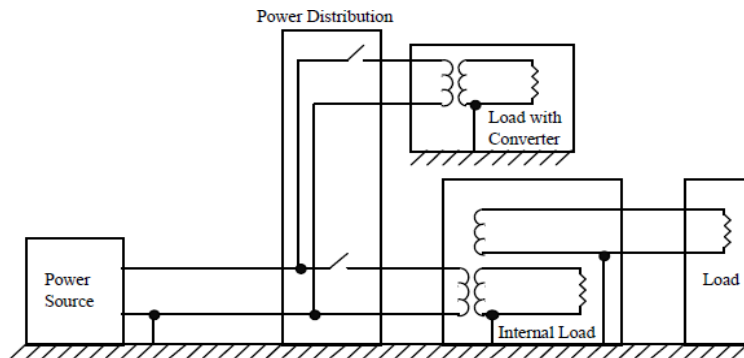

For Notional Purposes Only

**Figure 1. Single-Point Grounds General-Purpose Ground Method**

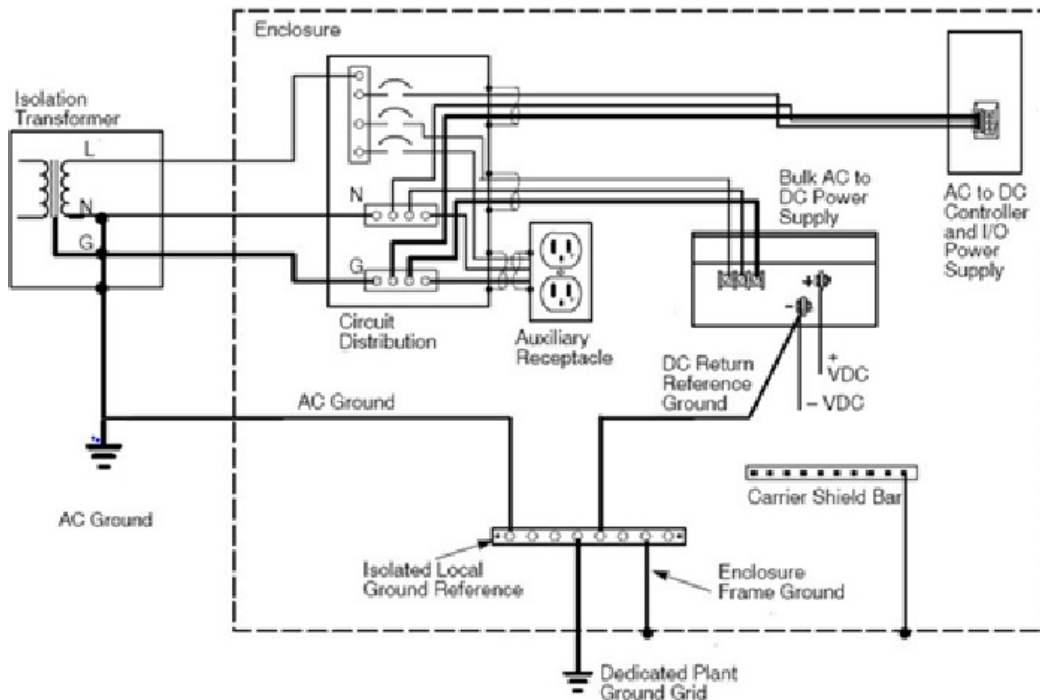

**Figure 2. Single-Point GS Grounds Typical Single-Point Ground Network for a Control System Housed in a Single Enclosure**

*Reference – PD-ED-1214*

### 5.2.7 Use of Multipoint GS Grounds

- a. Single-ended circuits with frequencies above 2 MHz shall use cable with connectors having 360-degree shields terminated at each and bonded to the bulkhead mating surface.
- b. All overall cable shields terminating in connectors shall be connected to a connector backshell that provides 360-degree shielding of the conductors.
- c. All connectors shall be bonded to the mating panel or enclosure to provide electrical continuity across the interface and to the grounding circuit.
- d. Single-ended circuits utilizing coaxial cable with shields that are isolated from ground shall require triaxial cable with overall shield terminated 360 degrees at each end and bonded to the mating surface.

Another grounding alternative is multipoint grounding. As shown in Figure 3, each item of equipment or subsystem is bonded as directly as possible to a common low-impedance ground.



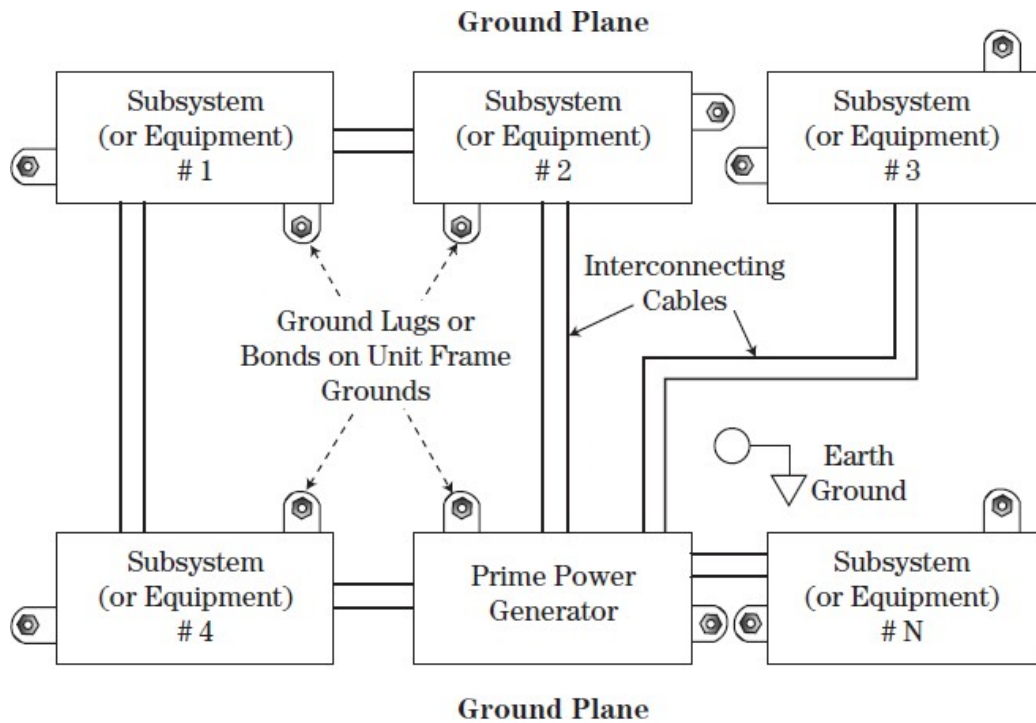

**Figure 3. Multipoint GS Grounds**

*Reference – PD-ED-1214*

### **5.2.8 Ground Special Power (GSP) Grounding**

- a. The input AC power neutral wire for GSP supplies shall be connected to the facility power ground system at the power source for the circuit supplying the GSP.
- b. The GSP enclosures shall be connected to facility ground at the enclosure
- c. The return wires (-D) of the DC GSP supplies sourcing flight power systems shall be connected as specified by Flight-to-Ground Interface Control Documents (ICD). See Figure 4.
- d. The return wires (-D) of the DC GSP supplies sourcing ground systems shall be connected together, isolated and grounded at a single point near the sources. See Figure 5.

*Reference – NFPA 70 and imposed program ICDs*

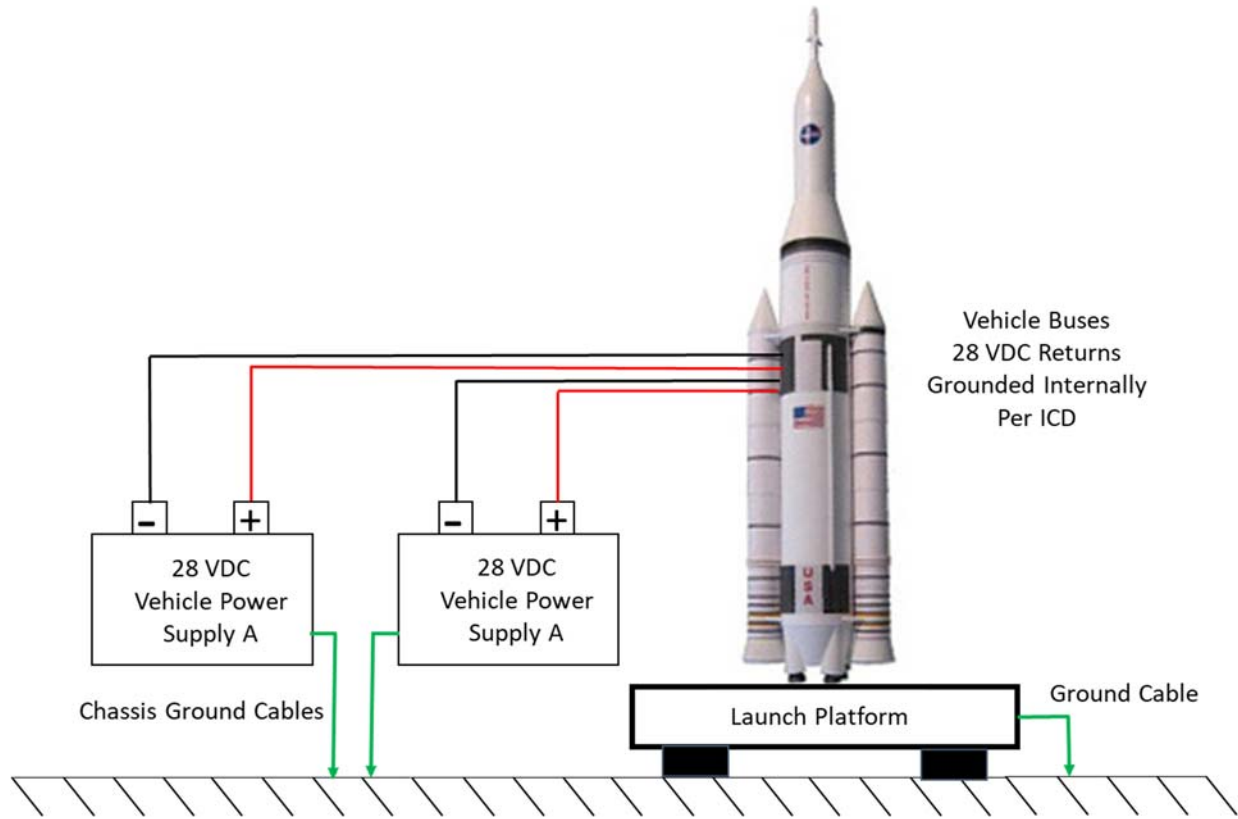

Figure 4. GSP Grounding for DC Buses in Vehicle

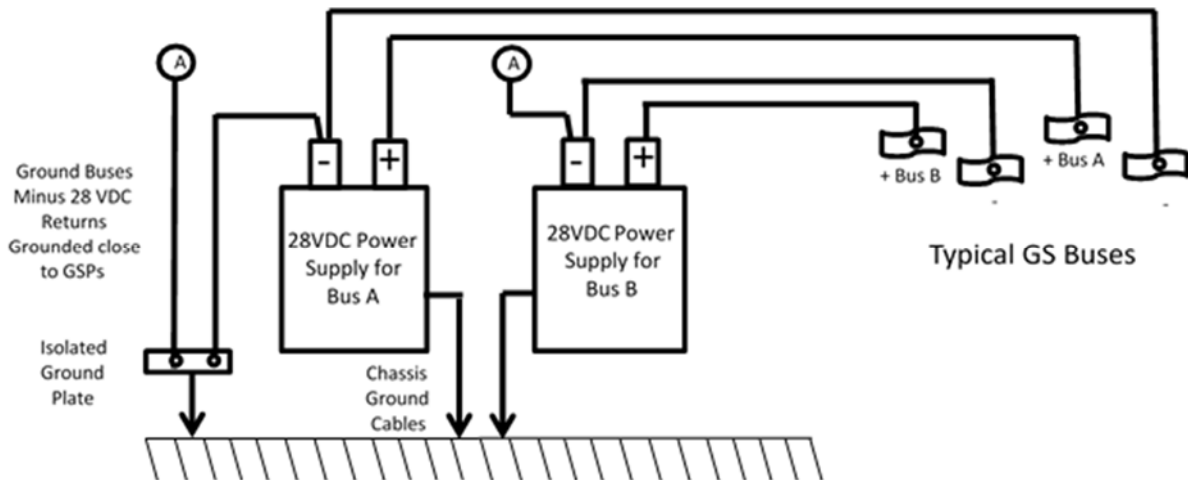

Figure 5. GSP Grounding for DC Buses in GS

### 5.3 Electromagnetic Interference (EMI)

- a. Ground systems shall be electromagnetically compatible within themselves such that system operational performance requirements are met. Compliance shall be verified by system-level test, analysis, or a combination thereof.
- b. Systems, subsystems, and equipment shall be capable of providing full performance in conjunction with other subsystems and equipment that are required to operate concurrently. Compliance shall be verified by system-level test, analysis, or a combination thereof.
- c. Electrical and electronic ground systems shall be designed to perform when exposed to a minimum level of 20 volts per meter (V/m) in the frequency range from 30 Hz to 18 GHz in accordance with the electromagnetic compatibility requirements in MIL-STD-461, Requirements for the Control of Electromagnetic Interference Characteristics of Subsystems and Equipment.
- d. If the testing in accordance with MIL-STD-461 is performed at a distance other than 1.0 meter or has other tailoring, the GSE shall be placarded with the test distance and a warning, "No electronic equipment within XX meters" and the tailoring shall be documented using KSC form 50-386.

*The NASA Technical Authority for electrical and electronic design has the authority to approve tailored tests plans, requirements and specific test parameters to meet the requirements of KSC-STD-E-0022. Request for tailoring of EMC testing requirements shall be documented and approved using KSC Form 50-386, see Appendix B.*

*Program requirements or the local EMI environment for a specific application may require a level higher than 20 V/m. The application of MIL-STD-461 to GS should be based on an evaluation of the potential for flight hardware interaction and any existing commercial standards to which the hardware is already certified. General facility systems are not required to adhere to this section.*

#### 5.3.1 EMI Testing

EMI testing shall be conducted on all ground systems having electrical/electronic circuits and equipment that have not been previously tested and certified.

*This EMI testing will provide the required certification for compliance with the applicable test requirements of MIL-STD 461.*

#### 5.3.2 Primary Qualification Test Requirements

Electrical/electronic ground systems shall meet the qualification test requirements of individual, and/or tailored MIL-STD-461 tests as listed in Table 2, inspected to meet the intent of

MIL-STD-461 in conjunction with EMC test and/or analysis based on the operational electromagnetic environment.

*Table 2 is a suggested EMC certification testing plan; therefore tailoring can be applied to the designer's degree of protection provided in the area of the system platform.*

**Table 2. MIL-STD-461 Tests for GS Certification**

Equipment Category	MIL-STD-461 Applicable Tests <sup>6</sup>												
	CE102 <sup>13</sup>	CE106	CS101 <sup>8</sup>	CS103 <sup>3</sup>	CS104 <sup>3</sup>	CS105 <sup>3</sup>	CS106 <sup>10,11,12</sup>	CS114 <sup>11</sup>	CS115 <sup>9,11</sup>	CS116 <sup>10,11</sup>	RE102 <sup>4,6</sup>	RE103	RS103 <sup>5,6</sup>
GSE <sup>1</sup> ; uses facility or GSP power; fixed installation or portable usage inside or outside flight system physical processing area <sup>2</sup>	✓		✓				✓	7✓	✓	✓	✓		✓
GSE <sup>1</sup> ; uses standalone battery power; portable usage inside or outside flight System physical processing area <sup>2</sup>											✓		✓
RF GSE <sup>1</sup> ;(antenna ports)	✓	3✓	✓	3✓	3✓	3✓	✓	7✓	✓	✓	✓	3✓	✓
GSS <sup>1</sup> ; uses facility or GSP power; electrical interface with GSE (other than GSP power)	✓		✓				✓	7✓	✓	✓	✓		✓
GSS; standalone battery power; radio system handheld transceivers		3✓		3✓	3✓	3✓					✓	3✓	✓
GSS; uses facility or GSP power; fixed installation; Radio System, base, adapted mobile, and handheld/charger stacks in operational areas.	✓	3✓	✓	3✓	3✓	3✓	✓	7✓	✓	✓	✓	3✓	✓

*Notes for Table 2:*

*1. May be direct electrical interface, indirect electrical interface passively-through another system cabling (e.g., GS umbilical system), or through radiated emissions, radiated susceptibility, conductive emissions, or conductive susceptibility by close proximity of electrical hardware. CE102 for GSE directly connected to facility power can be tailored to a characterization test to determine if ripple added to facility power is an issue for other GSS/GSE systems tied to the same facility circuit. Variances will be documented within the test report. Facility GSS systems are not required to meet MIL-STD-461 unless contracted to electrically interface with GSE Flight systems.*

*2. Within enclosed processing bays in GS element facilities; or on Mobile Launcher exterior platforms, decks, or umbilical structures; or on any GS conveyance for flight systems; with spacecraft or vehicle present in all cases within internal enclosure.*

3. For devices with non-detachable antennas, use RE103, otherwise CE106. For devices that have removable antennas also perform CS103, CS104, and CS105 (if required by the system).

4. Use the U.S. Air Force RE102 limits for all GSE and ground support system (GSS) as protection provided in the area of the platform.

5. Use the element- and location-specific radio frequency (RF) environmental definitions herein as RS103 limits; necessary margins are built into the definitions.

6. When MIL-STD-461 specifies multiple military-branch-specific test levels for specific tests other than RE102 and RS103, use values specified for the U.S. Air Force. Specific tailoring can be approved by the OPRD of this document.

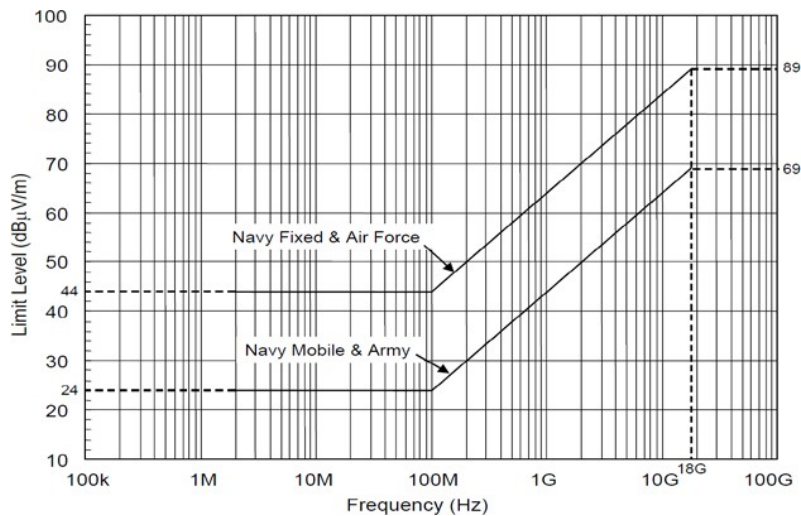

7. CS114 curve amplitude can be tailored based on the degree of protection provided interconnecting cabling will be located. Curve 4 is suggested for items meeting the 50V/m requirement and Curve 3 for all other systems in need to meet 20V/m.

TABLE VI-A CS114 Limit Curves		
Frequency Range MHz	Non-Critical Equipment	Critical Equipment
0.15 – 30	Curve 1	Curve 3
30-80	Continue flat portion of curve 1, do not follow the negative slope above 30MHz	Continue flat portion of curve 3, do not follow the negative slope above 30MHz

8. CS101 not required for current driven signal sources for transducers.

9. CS115 required for new hardware equipment.

10. CS 116 and CS 106 a consideration for the requirement is whether momentary upsets are allowable if the equipment under test (EUT) is capable of self-recovery to normal operation.

*Some upsets may occur that are not even noticed by an operator due to self-correcting mechanisms in the equipment. There may be cases where longer-term upset is acceptable which may possibly require action by an operator to reset the equipment. The Electromagnetic Interference Test Plan (EMITP) should address any instances where the design engineer proposes that observable upsets be accepted.*

- (a) not required for battery-operated devices*
- (b) Possible tailoring of the requirements by the procuring activity in contractual documents is adjustment of the curve amplitude either higher or lower based on the degree of protection provided in the area of the platform where the equipment and interconnecting cabling will be located. A caution with this particular requirement based on past experiences is that the platform designer should be required to share in the burden of the hardening process by providing stress reduction measures in the platform.*

*11. For certain testing performed in the past using bulk cable drive techniques, overall cable shields were routinely removed and the injected signal was applied to the core wiring within the shield. The intent of this standard is to test cables as they are configured in the installation. If the cable uses an overall shield, the test signal is applied to the overall shielded cable. If the procuring agency desires that the test be performed on the core wiring, specific wording needs to be included in contractual documentation.*

*12. CS106 waveform for legacy/heritage equipment: Alternative test for CS115 on unshielded cables.*

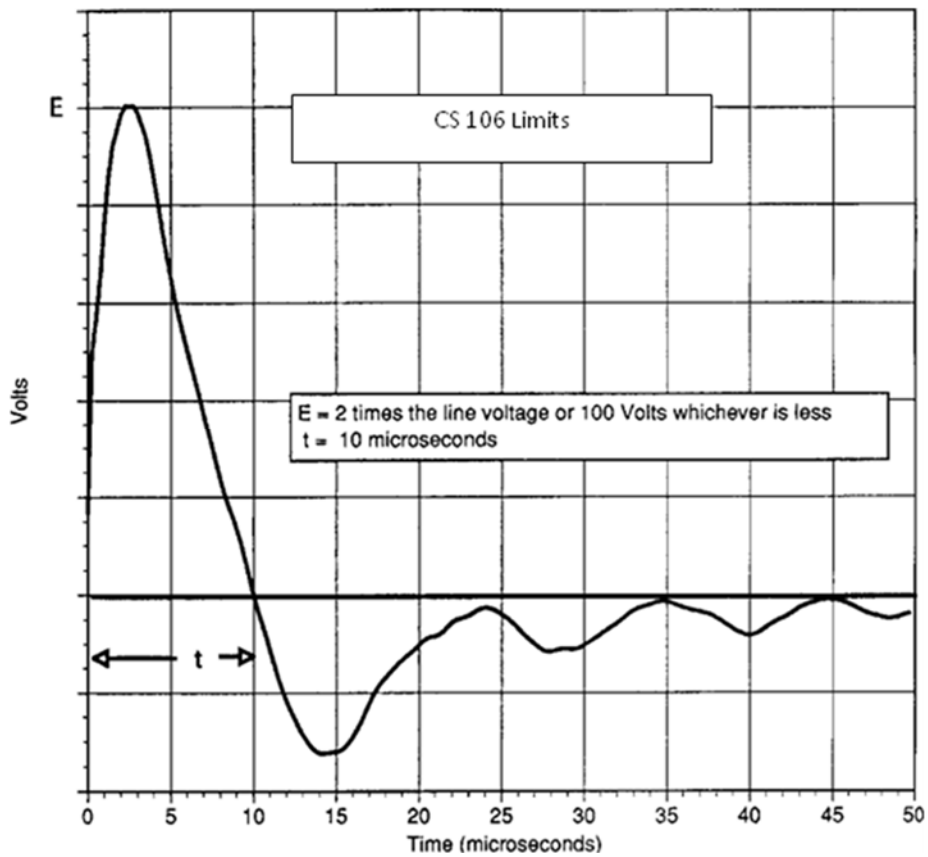

13. CE102 conducted emissions on power leads this requirement is applicable from 10 kHz to 10 MHz for all power leads, including returns, which obtain power from other sources not part of the EUT. Deviations from MIL-STD-461 can be inspected to meet the intent of this standard in conjunction with EMC test and/or tailoring analysis based on the operational electromagnetic environment or commercial industry standard for allowable conductive emissions.

Note: The frequency range from 2MHz to 18GHz is suggested for testing devices unless the electromagnetic environment frequency interference has been determined by measuring the environment.

### 5.3.3 Alternate Qualification Test Requirements

Electrical/electronic ground systems in proximity to EMI susceptible equipment and specifically deemed to pose a potential risk, shall meet the original MIL-STD-461 EMC test plan or previously approved tailored test plan below. In the event of noncompliance to the MIL-STD-461 test plan, a new tailored MIL-STD-461 test plan must be agreed upon by the OPRD of this document.

- a. All network servers (i.e., IBM or OEM servers) shall operate in the electromagnetic environment as referenced radiated susceptibility (RS) levels at 5V/m.
- b. The Launch Control System front firing room shall operate in the electromagnetic environment as referenced RS levels at 50V/m.
- c. The Launch Control System back firing room shall operate in the electromagnetic environment as referenced RS levels at 20V/m.
- d. The placard that defines the separation distance of xx.x meters is illustrated in Appendix A and will be posted in accordance with Appendix A.
- e. The separation distance shall be determined by the design agency that determines restriction of RF devices deemed to pose a potential risk.

*Note: MIL-STD-461 provides limits specific to military services which must be interpreted and tailored specifically for other applications such as COTS implementation. The test methodology remains the same.*

## **5.4 GS Testing**

GS Testing shall include, as a minimum CE102, CE106, CS101, CS103, CS104, CS105, CS106, CS114, CS115, CS116, RE102, RE103, and RS103, within the following MIL-STD-461 tests as identified in Table 2. Tailoring the EMC test criteria is approved by the OPRD.

## **5.5 Shielding**

Ground Systems shall incorporate shielding features in electrical and electronic designs of circuits, cables and enclosures to meet electromagnetic susceptibility and emission requirements of MIL-STD-461 and program requirements.

*Shielding is required in electrical and electronic equipment to prevent the equipment from propagating interference and to protect the equipment from the effects of interference propagated from other electrical and electronic devices. Shielding design requirements are also provided in FAA-STD-0019 and FAA-STD-020. Fabrication requirements and best practices for shielding are in KSC-E-165.*

### **5.5.1 Code Requirements**

To ensure safety of personnel from electrical/electronic hazards, NFPA 70 requirements for shielding shall be reviewed and employed in addition to other standards for GS designs.

*NFPA70 is the controlling document for design and implementation safety features and controls for electrical components and systems.*



## 5.5.2 Types of Wire, Harnesses, and Cable Shielding

Termination of individual shields shall be a function of the circuit design and are required to be carried through a connector with an adjacent pin and terminated at destination to a system/instrumentation ground path. Shields used as a return path are exempted from this requirement. Termination of overall cable shields shall be accomplished as defined in 5.5.2.f. and in accordance with KSC-E-165 and KSC-E-166 to achieve a value of 2.5 milliohm or less across the interface.

- a. Terminating and grounding shields shall be installed in accordance with NASA-STD-8739.4 and KSC-E-165.
- b. GS wires, harnesses and cables with multiple twisted pairs shall have individual insulated shields for each pair.
- c. GS cables and harnesses with single conductors shall have individual insulated shields for each wire.
- d. GS shielding designs shall be used inside the electrical/electronic equipment and cables to prevent unwanted coupling.
- e. GS overall shields shall be provided for all cables that are exposed to electric/magnetic fields such as motors, starters and potential electric/magnetic fields such as may be experienced from lightning effects.
- f. GS overall shields shall provide electrical connectivity to connector backshells to provide required RFI shielding to the cable assembly.
- g. Where GS cable assemblies are connected to bulkhead or jam nut connectors mounted on conductive panels, designs shall ensure presence of conductive ground paths through the panel to the mating connector and to earth ground.

*Reference – MIL-HDBK-1857 and PD-ED-1214*

**Note:** Facility shielding requirements are provided in KSC-STD-E-0012.

## 5.5.3 GS Shielding Effectiveness of Electrical Enclosures

- a. Enclosures shall provide adequate shielding for signal attenuation between 2 megahertz (MHz) and 30 gigahertz (GHz) as necessary to meet the EM requirements specified in the engineering drawings or procurement specification. Enclosures utilized in an EM environment as referenced RS levels of 20V/m shall provide a minimum shielding signal attenuation of 26 decibels (dB) over the frequency range of 2 MHz to 18 GHz. Enclosures utilized in an EM environment as referenced RS levels of 50V/m shall provide a minimum shielding signal

attenuation of 34 decibels (dB) over the frequency range of 2 MHz to 18 GHz. For higher-frequency environments, an upper limit of 30 GHz may be used.

- b. Testing of typical shielding designs shall serve to qualify like designs.

*Reference – MIL-HDBK-1857, KSC-SPEC-E-0002, and PD-ED-1213*

#### **5.5.4 Routing and Separation of Signals**

- a. Routing and separation of signals shall be a function of the system design to ensure integrity and performance of the detailed design.
- b. Cables or wires carrying high-impedance signals shall be routed a minimum of 0.1 meters (4 inches) from power level signal lines.
- c. Routing of wiring and cables shall be performed in a manner that does not jeopardize integrity and performance of the ground system.
- d. Wiring and cables carrying high-level signals or power shall be routed as far as feasible from low-level signals.
- e. Low-frequency signals having impedances of 100 ohms or lower may be routed by unshielded twisted pair (UTP) conductors.
- f. Low-frequency signals having impedances above 100 ohms should be routed by shielded twisted pair (STP).
- g. High-frequency signals having any impedance shall be shielded and grounded at multipoints.

*Reference – MIL-HDBK-1857*

#### **5.5.5 Equipment Rack, Panel and Enclosure Shielding**

- a. GS electrical equipment racks, panels and enclosures shall contain shielding to protect sensitive components from harmful radiated and conducted electrical effects.
- b. Electrical/electronic GS shall use EMI rated enclosures combined with bulkhead connectors with EMC backshells to provide protection to electrical circuitry within the enclosure.
- c. GS electrical equipment racks, panels and enclosures shall contain shielding to protect personnel from harmful radiated electrical effects.

- d. Shielding of racks, consoles, and modular enclosures shall be in accordance with KSC-SPEC-E-0002.

*Reference – MIL-HDBK-1857 and KSC-SPEC-E-0002*

### **5.5.6 Power Cable Shielding**

All rack, panel, console, and enclosure interior GS power cables should consider using a 360-degree overall shield to minimize electromagnetic environmental effects generated by power transients and induction coupling to nearby circuits.

*Typically power cables are not shielded but when nearby switching power supplies and motor generate magnetic fields are generate within rack, console, panel, and enclosure.*

*Reference – MIL-HDBK-1857 and KSC-GP-864*

### **5.5.7 Instrumentation and Control Cable Shielding**

- a. All instrumentation and control cables shall have at least a 360-degree overall shield to minimize electromagnetic and electrical effects as required by the circuit design requirements.
- b. Terminating and grounding shields shall be installed in accordance with NASA-STD-8739.4 and KSC-E-165.

*Reference – NASA-STD-8739.4, KSC-GP-864*

### **5.5.8 Operational Communication Cable Shielding**

Operational communication cables and transmission lines shall be designed for protection against harmful transient voltages and surges that may be experienced from internal and external sources.

*Reference – MIL-HDBK-419*

## **5.6 GS Lightning Protection**

GS lightning protection shall be provided to minimize harmful effects to personnel and equipment. Designs for lightning protection include lightning arresters, bonding and grounding of metallic structures including racks/enclosures, and lightning protection systems from facilities.

*Reference – NFPA 780, MIL-STD-188-124, and KSC-STD-E-0012*

### **5.6.1 Code Requirements**

Protection of ground systems shall be in accordance with NFPA 780.

*Reference NFPA 78 as guidance for areas not within NFPA 780.*

### **5.6.2 GS Shielded by Lightning Protection Systems**

GSE located outdoors and shielded by a lightning protection system shall meet its operational performance requirements after being subjected to the indirect effects of lightning defined as follows:

Magnetic field rate of change =  $\frac{130 \text{ amperes}}{\text{meter}}$  per  $\mu\text{sec}$

Electric field rate of change =  $\frac{40 \text{ kilo-volts}}{\text{meter}}$  per  $\mu\text{sec}$

*Reference – NASA-STD-5005*

### **5.6.3 GS Not Shielded by a Lightning Protection System**

GSE not shielded by a lightning protection system shall meet its operational performance requirements after being subjected to the indirect effects of lightning defined as follows:

Magnetic field rate of change @10 meters =  $\frac{2200 \text{ amperes}}{\text{meter}}$  per  $\mu\text{sec}$

Electric field rate of change @ 10 meters =  $\frac{680 \text{ kilo-volts}}{\text{meter}}$  per  $\mu\text{sec}$

*Reference NASA-STD-5005*

*Note: Indirect effects of lightning are electrical transients due to coupling of electromagnetic fields to GS electrical circuitry that may cause damage to or malfunction of electrical/electronic equipment. GS should be located in areas where lightning protection is provided or designed to sustain a near-direct (within 10 meters) lightning strike. GS located in some protected areas will experience very high induced voltages and current from nearby lightning strikes and must provide additional protection to ensure each GS item will perform as designed. Direct lightning strokes to GS may not be prevented, but GS designs should minimize exposure to all environmental effects.*

*Reference – NASA-STD-5005*

### **5.6.4 Piping, Tubing, and Ducts (Considered here to be GS)**

- a. Piping, tubing, and ducts shall be grounded at each end as a minimum with an AWG # 6 flexible copper wire or braid. Piping, tubing, and ducts 200-feet-long or longer shall be grounded every 100 feet. Figure 6 illustrates typical mechanical joint bonding methods.

- b. Bonding of equipment with bolts or other identified means shall be permitted if paint and dirt are removed from the joint surface or bonded members are effectively penetrated (NFPA 79 paragraph 8.2.3.3).
- c. Piping and tubing external to lightning-protected areas, such as cross-country propellant lines shall have overhead wire protection in accordance with KSC-STD-E-0012.
- d. Low-impedance, (100 milliohm, as a maximum, for acceptable conductivity) shall be maintained through each coupling and joint.
- e. The series resistance of the piping, tubing, and duct joints shall not exceed a total of 1 ohm from earth grounding system to earth ground.
- f. Flanged joints shall have a conductive clip attached to one bolt, as a minimum, to provide an electrical conductive path across the mechanical joint. Figure 6 illustrates typical clip attachments.
- g. Flare stacks shall contain conductive joints and an AWG #6 flexible copper wire at the lowest end connected to a certified earth grounding system.

*Reference – This Standard and NASA-STD-4003*

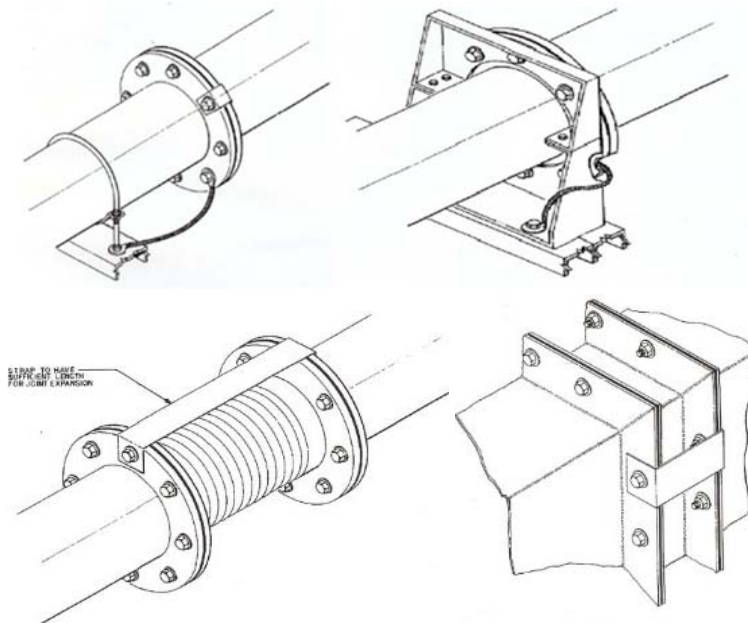

**Figure 6. Typical Methods of Providing Electrical Continuity across Mechanical Joints with Different Conductive Material, such as Aluminum to Steel**

## **5.7 ML (Considered to be GS)**

The ML shall be designed with ground attach points to provide a low-impedance path connection to the local ground system to safely conduct currents from lightning effects.

*Reference – This Standard*

### **5.7.1 MLT Access and Service Arms**

- a. Moveable joints used in access arms and service arms shall have an electrical jumper across the pivot point to conduct any fault/stray currents across the joint verified to 100 milliohms or less.
- b. A 360-degree overall shielding shall be provided for all electrical cables installed on the arms.

*Reference – This Standard*

### **5.7.2 MLT GS Enclosures**

- a. All GS enclosures shall be bonded to the MLT structure.
- b. Isolated single-point ground plates shall be provided in the GS electrical equipment room.

*Reference – This Standard*

### **5.7.3 MLT Electrical Cables**

- a. Exterior long-run electrical cables shall have a 360-degree overall shield.
- b. Exterior long run electrical cables that are routed vertically shall be installed in cable trays having bonded metallic covers.

*Reference – This Standard*

## **5.8 Lightning Detection and Measurement Instrumentation**

Instrumentation shall be provided to record the presence of and effects from lightning strikes in order to evaluate potential damage and test requirements for GS and FS at the launch pad and at other facilities as required by the program or project.

*Reference – This Standard*

## 5.9 Electrostatic Discharge (ESD) Protection

- a. All ESD-sensitive components and assemblies shall be handled using practices in accordance with:
  - (1) ANSI/ESD S20.20, For the Development of an Electrostatic Discharge Control Program for - Protection of Electrical and Electronic Parts, Assemblies and Equipment (Excluding Electrically Initiated Explosive Devices).
  - (2) MIL-STD-1686, Electrostatic Discharge Control Program for Protection of Electrical and Electronic Parts, Assemblies and Equipment (Excluding Electrically Initiated Explosive Devices).
  - (3) MIL-HDBK-263, Electrostatic Discharge Control Handbook for Protection of Electrical and Electronic Parts, Assemblies and Equipment (Excluding Electrically Initiated Explosive Devices) (Metric).
- b. All GS electrical and electronic equipment, subassemblies and components subject to damage from exposure to electrostatic fields or ESD shall be protected by proper bonding and grounding methods.
- c. ESD-controlled areas shall be provided for all fabrication, storage, repair, and maintenance spaces used for electrical and electronic equipment or subassemblies that are subject to damage from static electricity or ESD.
- d. All GS electrical and electronic equipment, subassemblies and components outside protected areas subject to damage from exposure to electrostatic fields or ESD shall be protected by proper bonding and grounding.
- e. All GS in the installed and operational configuration shall withstand a static discharge of 15,000 volts per JS-0001-2012, ESD Association Standard Test Method ESD-STM 5.1, Electrostatic Discharge Sensitivity Testing – Human Body Model (HBM).
- f. GS tested shall not suffer any operational upset or damage to any component or assemblies to pass ESD requirements.

*Reference – FAA-STD-019*

## 5.10 Transient Voltage and Surge Suppression

Ground Systems that contain electrical and electronic equipment shall be protected from damage caused by conducted and radiated surges and transients from all power, signal, control and/or status lines.

*Reference – NASA-STD-5005, MIL-HDBK 419, and FAA-STD-020*

### **5.10.1 Power Line Filtering**

Ground systems that are sensitive to transient voltage disturbances shall be equipped with filters or surge suppressors to protect all system sensitive circuits from damage.

*Reference – PD-ED-1206*

### **5.10.2 Communication Line Filtering**

Communication circuits and transmission lines shall be designed for protection against damaging transient voltages and surges that may be experienced from internal and external sources.

*Reference – This Standard*

### **5.10.3 Electrically Inductive Component Transient and Surge Suppression**

- a. Back EMF voltages generated from inductive components, such as coils of electrically operated valves, shall be measured by test to determine the appropriate suppression device required to protect associated circuitry.
- b. Inductive components shall be equipped or supplemented with surge suppression devices capable of protecting associated circuitry.

*Reference – This Standard*



**NOTICE.** The Government drawings, specifications, and/or data are prepared for the official use by, or on behalf of, the United States Government. The Government neither warrants these Government drawings, specifications, or other data, nor assumes any responsibility or obligation, for their use for purposes other than the Government project for which they were prepared and/or provided by the Government, or any activity directly related thereto. The fact that the Government may have formulated, furnished, or in any way supplied the said drawings, specifications, or other data is not to be regarded, by implication or otherwise, as licensing in any manner the holder or any other person or corporation nor conveying the right or permission to manufacture, use, or sell any patented invention that may relate thereto.

Custodian:

Preparing Activity:

NASA – John F. Kennedy Space Center  
Kennedy Space Center, Florida 32899

John F. Kennedy Space Center

**APPENDIX A. DISPLAY PLACARDS EXAMPLE**

These placards shall be visible and placed by the OPR of the subsystem in accordance with OSHA 29 CFR 1910-145.

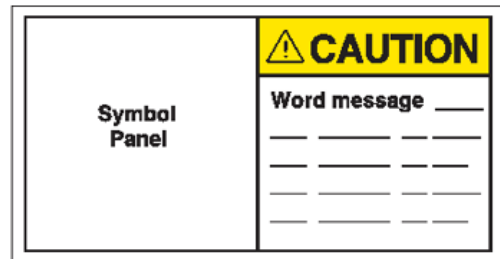
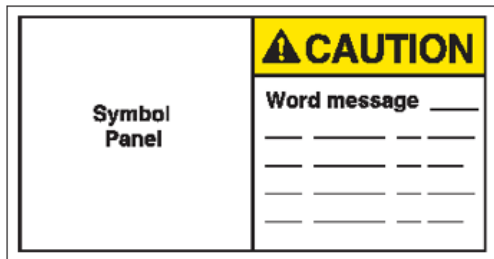
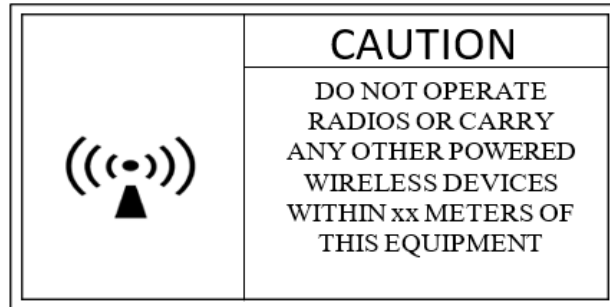

Note: the distance “xx” should be determined by OPRD.

**APPENDIX B. KSC-STD-E-0022 ELECTROMAGNETIC COMPATIBILITY  
 TAILORING REQUEST FORM (KSC FORM 50-386)**

KSC-STD-E-0022 Electromagnetic Compatibility Tailoring Request			
Submittal Date (MM/DD/YYYY)		Tailoring Request Number (Assigned by KSC-STD-E-0022 Technical Authority)	
Originator Name (Last Name, First Name)	Originator Phone Number	Originator Email Address	Organization & Mail Code
Program/Project	Subsystem	Item Description	Manufacturer/Part Number/Drawing Number
Issue Description. (Describe difficulty in meeting requirement. Cite specific KSC-STD-E-0022 section to be tailored)			
Tailoring Description (Describe proposed changes to the requirement)			
Rationale (Include: Impacts if tailoring is not approved, Risks if tailoring is approved, mitigations to control risks)			

KSC FORM 50-386 12/18 (1.0) PREVIOUS EDITIONS ARE OBSOLETE. Validate prior to use.

Submit by Email

Page 1 of 2

KSC-STD-E-0022

April 11, 2013

Change 2, February 5, 2019

KSC-STD-E-0022 Electromagnetic Compatibility Tailoring Request				
Restrictions, Limitations of Tailoring, Comments (To be filled in by KSC-STD-E-0022 Technical Authority)				
<b>Concurrence</b>				
Name	Date	Title	Concurrence (Yes/No)	Signature
		Program/Project		
		Project Engineer		
		Systems Engineer		
		Electromagnetics Lab		
		Labs, Development & Testing (NASA)		
		Safety & Mission Assurance		
		KSC-STD-E-0022 Technical Authority (NASA)		
		Electrical Chief Engineer (NASA)		
<b>Tailoring Disposition</b>				
Date	<input type="text"/>	Approve <input type="checkbox"/>	Withdrawn <input type="checkbox"/>	Rejected <input type="checkbox"/>

KSC FORM 50-386 12/18 (1.0) PREVIOUS EDITIONS ARE OBSOLETE. Validate prior to use.

Submit by Email

Page 2 of 2

Go to <https://nef.nasa.gov/> to download form.

## **APPENDIX C. ELECTROMAGNETIC COMPATIBILITY MANAGEMENT PLAN OUTLINE**

An electromagnetic compatibility management plan (EMCMP) should be developed for GSE as part of the formulation stage and included as an engineering product in the design review process.

The EMCMP shall address the following management areas:

- a. Organizational responsibilities, lines of authority and control
- b. Detailed EMI requirements imposed on the project, subsystem and contracts.
- c. EMI test plan including any proposed tailoring
- d. Description of the equipment or subsystem, criticality, its function, characteristics, concept of operations, use of data and intended installation.
- e. Location of equipment, operational environment, operational restrictions and controls (i.e., EMI clear zones).
- f. Role in program of Government Furnished Equipment and subcontractor items.
- g. Plans and procedures for identifying and resolving potential EMI problems, implementing solutions, and verifying solutions through analysis and testing. Technical point of contact for EMI technical issues.
- h. Control of the hazards of electromagnetic radiation to personnel
- i. Control of Electrostatic Discharge (ESD)
- j. Design mitigations used to meet EMC requirements:
  - Spectrum management techniques.
  - Grounding philosophy
  - Electrical wiring design, including cable types or characteristics, cable routing, cable separation, cable shielding types and termination methods.
  - EMI mechanical design, including the following:
    - Type of metals, casting, finishes, and hardware employed in the design.

- Construction techniques, such as isolated compartments; filter mounting, isolation of other parts; treatment of openings (ventilation ports, access hatches, windows, metal faces and control shafts), and attenuation characteristics of Radio Frequency (RF) gaskets used on mating surfaces.
- Shielding provisions and techniques used for determining shielding effectiveness.
- Corrosion control procedures.
- Methods of bonding mating surfaces, such as surface preparation and gaskets.
- Electrical and electronic circuit design, including the following:
  - Filtering techniques, technical reasons for selecting types of filters, and associated filter characteristics, including attenuation and line-to-ground capacitance values and leakage current of AC and DC power line filters.
  - Part location and separation for reducing EMI.
  - Location, shielding, and isolation of critical circuits.



KSC-STD-E-0022  
April 11, 2013  
Change 2, February 5, 2019

This page intentionally left blank.



# STANDARDIZATION DOCUMENT IMPROVEMENT PROPOSAL

## INSTRUCTIONS

1. The preparing activity must complete blocks 1, 2, 3, and 8. In block 1, both the document number and revision letter should be given.
2. The submitter of this form must complete blocks 4, 5, 6, and 7.
3. The preparing activity must provide a reply within 30 days from receipt of the form.

NOTE: This form may not be used to request copies of documents, nor to request waivers or clarification of requirements on current contracts. Comments submitted on this form do not constitute or imply authorization to waive any portion of the referenced document or to amend contractual requirements.

### **I RECOMMEND A CHANGE:**

1. DOCUMENT NUMBER

KSC-STD-E-0022, Basic, Change 2

2. DOCUMENT DATE

December 20, 2018

3. DOCUMENT TITLE

Bonding, Grounding, Shielding Electromagnetic Interference, Lightning, and Transient Protection, Design Requirements for Ground Systems

4. NATURE OF CHANGE *(Identify paragraph number and include proposed rewrite, if possible. Attach extra sheets as needed.)*

5. REASON FOR RECOMMENDATION

### **6. SUBMITTER**

a. NAME *(Last, First, Middle Initial)*

b. ORGANIZATION

c. ADDRESS *(Include Zip Code)*

d. TELEPHONE *(Include Area Code)*

7. DATE SUBMITTED

### **8. PREPARING ACTIVITY**

a. NAME

Engineering Directorate

b. ORGANIZATION

NASA

c. ADDRESS *(Include Zip Code)*

John F. Kennedy Space Center Kennedy Space Center, FL, 32899